

# SAND REPORT

SAND2011-2498  
Unlimited Release  
Printed May 2011

---

## Xyce™ Parallel Electronic Simulator

---

### Reference Guide, Version 5.2

Eric R. Keiter, Ting Mei, Thomas V. Russo, Eric L. Rankin, Roger P. Pawlowski, Richard L. Schiek, Keith R. Santarelli, Todd S. Coffey, Heidi K. Thornquist, Christina E. Warrender, Deborah A. Fixel

Prepared by  
Sandia National Laboratories  
Albuquerque, New Mexico 87185 and Livermore, California 94550

Sandia National Laboratories is a multi-program laboratory managed and operated by Sandia Corporation, a wholly owned subsidiary of Lockheed Martin Corporation, for the U.S. Department of Energy's National Nuclear Security Administration under contract DE-AC04-94AL85000.

Approved for public release; further dissemination unlimited.



Issued by Sandia National Laboratories, operated for the United States Department of Energy by Sandia Corporation.

**NOTICE:** This report was prepared as an account of work sponsored by an agency of the United States Government. Neither the United States Government, nor any agency thereof, nor any of their employees, nor any of their contractors, subcontractors, or their employees, make any warranty, express or implied, or assume any legal liability or responsibility for the accuracy, completeness, or usefulness of any information, apparatus, product, or process disclosed, or represent that its use would not infringe privately owned rights. Reference herein to any specific commercial product, process, or service by trade name, trademark, manufacturer, or otherwise, does not necessarily constitute or imply its endorsement, recommendation, or favoring by the United States Government, any agency thereof, or any of their contractors or subcontractors. The views and opinions expressed herein do not necessarily state or reflect those of the United States Government, any agency thereof, or any of their contractors.

Printed in the United States of America. This report has been reproduced directly from the best available copy.

Available to DOE and DOE contractors from  
U.S. Department of Energy  
Office of Scientific and Technical Information  
P.O. Box 62  
Oak Ridge, TN 37831

Telephone: (865) 576-8401  
Facsimile: (865) 576-5728  
E-Mail: [reports@adonis.osti.gov](mailto:reports@adonis.osti.gov)  
Online ordering: <http://www.doe.gov/bridge>

Available to the public from  
U.S. Department of Commerce  
National Technical Information Service  
5285 Port Royal Rd  
Springfield, VA 22161

Telephone: (800) 553-6847  
Facsimile: (703) 605-6900  
E-Mail: [orders@ntis.fedworld.gov](mailto:orders@ntis.fedworld.gov)  
Online ordering: <http://www.ntis.gov/ordering.htm>



SAND2011-2498  
Unlimited Release  
Printed May 2011

---

# **Xyce™ Parallel Electronic Simulator**

## **Reference Guide, Version 5.2**

Eric R. Keiter, Ting Mei, Thomas V. Russo, Eric L. Rankin,  
Richard L. Schiek, and Heidi K. Thornquist  
Electrical Systems Modeling

Deborah A. Fixel  
Advanced Device Technologies

Todd S. Coffey  
Computational Simulation Infrastructure

Roger P. Pawlowski  
Multiphysics Simulation Technology

Keith R. Santarelli

Christina E. Warrender  
Cognitive Modeling

Sandia National Laboratories  
P.O. Box 5800  
Mail Stop 0316  
Albuquerque, NM 87185-0316

May 13, 2011

## **Abstract**

This document is a reference guide to the **Xyce** Parallel Electronic Simulator, and is a companion document to the **Xyce** Users' Guide. The focus of this document is (to the extent possible) exhaustively list device parameters, solver options, parser options, and other usage details of **Xyce**. This document is *not* intended to be a tutorial. Users who are new to circuit simulation are better served by the **Xyce** Users' Guide.

## Acknowledgements

The authors would like to acknowledge the entire Sandia National Laboratories HPEMS (High Performance Electrical Modeling and Simulation) team, including Steve Wix, Carolyn Bogdan, Regina Schells, Ken Marx, Steve Brandon and Bill Ballard, for their support on this project.

## Trademarks

The information herein is subject to change without notice.

Copyright © 2002-2011 Sandia Corporation. All rights reserved.

**Xyce™** Electronic Simulator and **Xyce™** trademarks of Sandia Corporation.

Portions of the **Xyce™** code are:

Copyright © 2002, The Regents of the University of California.

Produced at the Lawrence Livermore National Laboratory.

Written by Alan Hindmarsh, Allan Taylor, Radu Serban.

UCRL-CODE-2002-59

All rights reserved.

Orcad, Orcad Capture, PSpice and Probe are registered trademarks of Cadence Design Systems, Inc.

Silicon Graphics, the Silicon Graphics logo and IRIX are registered trademarks of Silicon Graphics, Inc.

Microsoft, Windows and Windows 2000 are registered trademark of Microsoft Corporation.

Solaris and UltraSPARC are registered trademarks of Sun Microsystems Corporation.

Medici, DaVinci and Taurus are registered trademarks of Synopsys Corporation.

HP and Alpha are registered trademarks of Hewlett-Packard company.

Amtec and TecPlot are trademarks of Amtec Engineering, Inc.

**Xyce's** expression library is based on that inside Spice 3F5 developed by the EECS Department at the University of California.

The EKV3 MOSFET model was developed by the EKV Team of the Electronics Laboratory-TUC of the Technical University of Crete.

All other trademarks are property of their respective owners.

## Contacts

Bug Reports

<http://joseki.sandia.gov/bugzilla>  
<http://charleston.sandia.gov/bugzilla>

World Wide Web

<http://xyce.sandia.gov>  
<http://charleston.sandia.gov/xyce>

Email

[xyce-support@sandia.gov](mailto:xyce-support@sandia.gov)



**Sandia National Laboratories**

# Contents

<b>1. Introduction</b>	<b>13</b>
1.1 Overview	14
1.2 How to Use this Guide	14
1.3 Third Party License Information	16
<b>2. Netlist Reference</b>	<b>19</b>
2.1 Netlist Commands	20
DC Sweep Analysis	20
STEP Parametric Analysis	23
Transient Analysis	27
Harmonic Balance Analysis	30
Multi-Time Partial Differential Equation (MPDE) Analysis	31
Device Modeling	32
Output Control	36
Netlist Processing	43
Miscellaneous Commands	45
.OPTIONS Statements	46
.PREPROCESS Statements	69
2.2 Analog Devices	72
Voltage Nodes	75
Capacitor	76
Inductor	79
Mutual Inductors	81
Resistor	85
Diode	89
Independent Current Source	95
Independent Voltage Source	99
Voltage Controlled Voltage Source	100
Current Controlled Current Source	101
Current Controlled Voltage Source	102

Voltage Controlled Current Source . . . . .	103
Nonlinear Dependent Source . . . . .	104
Bipolar Junction Transistor (BJT) . . . . .	105
Junction Field-Effect Transistor (JFET) . . . . .	116
Metal-Semiconductor FET (MESFET) . . . . .	119
MOS Field Effect Transistor (MOSFET) . . . . .	122
Voltage- or Current-controlled Switch . . . . .	254
Generic Switch . . . . .	257
Lossless (Ideal) Transmission Line . . . . .	258
Behavioral Digital Devices . . . . .	259
Accelerated mass . . . . .	263
Subcircuit . . . . .	264
2.3 TCAD Devices . . . . .	265
TCAD Device Parameters . . . . .	266
Physical Models . . . . .	271
Mobility Models . . . . .	274
<b>3. Command Line Arguments</b>	<b>291</b>
<b>4. Runtime Environment</b>	<b>293</b>
Running <b>Xyce</b> in Serial . . . . .	293
Running <b>Xyce</b> in Parallel . . . . .	293
Running <b>Xyce</b> on Sandia HPC Platforms . . . . .	293
<b>5. Setting Convergence Parameters for Xyce</b>	<b>295</b>
Adjusting Transient Analysis Error Tolerances . . . . .	295
Adjusting Nonlinear Solver Parameters (in transient mode) . . . . .	296
<b>6. Quick Reference for Orcad PSpice Users</b>	<b>299</b>
GUI Support . . . . .	299
Command Line Options . . . . .	299
Device Support . . . . .	299
Netlist Support . . . . .	299
Converting PSpice ABM Models for Use in <b>Xyce</b> . . . . .	300
Usage of .STEP Analysis . . . . .	301
Other differences . . . . .	302
<b>7. Quick Reference for ChileSPICE Users</b>	<b>305</b>

<b>8. Quick Reference for Microsoft Windows Users</b>	<b>309</b>
<b>9. Rawfile Format</b>	<b>311</b>
Ascii Format .....	311
Binary Format .....	311
Special Notes .....	311



## Tables

1.1	<b>Xyce</b> typographical conventions. . . . .	15
2.1	Options for Device Package . . . . .	49
2.2	Options for Time Integration Package. . . . .	55
2.3	Options for MPDE Package. . . . .	57
2.4	Options for HB. . . . .	57
2.5	Options for Nonlinear Solver Package. . . . .	62
2.6	Options for Continuation and Bifurcation Tracking Package. . . . .	63
2.7	Options for Linear Solver Package. . . . .	66
2.8	List of keywords and device types which can be used in a .PREPROCESS REMOVEUNUSED statement. . . . .	70
2.9	Analog Device Quick Reference. . . . .	74
2.10	Capacitor Device Parameters. . . . .	77
2.11	Capacitor Model Parameters. . . . .	78
2.12	Inductor Model Parameters. . . . .	80
2.13	Nonlinear Mutual Inductor Device Model Parameters. . . . .	83
2.14	Resistor Device Parameters. . . . .	86
2.15	Resistor Model Parameters. . . . .	86
2.16	Resistor Device Instance Parameters. . . . .	87
2.17	Resistor Device Model Parameters. . . . .	88
2.18	Diode Device Parameters. . . . .	90
2.19	Diode Model Parameters. . . . .	91
2.20	BJT Model Parameters. . . . .	109
2.21	VBIC Device Model Parameters. . . . .	112
2.22	JFET Device Parameters. . . . .	117
2.23	JFET Model Parameters. . . . .	118
2.24	MESFET Device Parameters. . . . .	120
2.25	MESFET Model Parameters. . . . .	121
2.26	MOSFET level 1 Device Model Parameters. . . . .	133
2.27	MOSFET level 2 Device Model Parameters. . . . .	135
2.28	MOSFET level 3 Device Model Parameters. . . . .	137

2.29 MOSFET level 6 Device Model Parameters. . . . .	139
2.30 BSIM3 Device Model Parameters. . . . .	154
2.31 BSIM3 SOI Device Model Parameters. . . . .	178
2.32 BSIM4 Device Instance Parameters. . . . .	180
2.33 BSIM4 Device Model Parameters. . . . .	208
2.34 Power MOSFET Device Parameters. . . . .	208
2.35 Power MOSFET Model Parameters. . . . .	211
2.36 PSP103VA MOSFET Device Instance Parameters. . . . .	212
2.37 PSP103VA MOSFET Device Model Parameters. . . . .	238
2.38 EKV3 MOSFET Device Instance Parameters. . . . .	239
2.39 EKV3 MOSFET Device Model Parameters. . . . .	247
2.40 Controlled Switch Model Parameters. . . . .	256
2.41 Lossless (Ideal) Transmission Line Parameters. . . . .	258
2.42 Behavioral Digital Device Parameters. . . . .	261
2.43 Behavioral Digital Model Parameters. . . . .	262
2.44 PDE Device Instance Parameters. . . . .	268
2.45 TCAD Device Model Parameters. . . . .	268
2.46 PDE Device Doping Region Parameters . . . . .	269
2.47 Description of the flatx, flaty doping parameters . . . . .	270
2.48 PDE Device Electrode Parameters. . . . .	270
2.49 Intrinsic Carrier Concentration Parameters . . . . .	272
2.50 Bandgap constants . . . . .	273
2.51 Analytic Mobility Parameters . . . . .	275
2.52 Arora Mobility Parameters . . . . .	276
2.53 Carrier-Carrier Mobility Parameters . . . . .	278
2.54 Lombardi Surface Mobility Parameters . . . . .	280
2.55 Material workfunction values. . . . .	287
2.56 Electron affinities . . . . .	287
3.1 List of <b>Xyce</b> command line arguments. . . . .	292
6.1 Incompatibilities with PSpice. . . . .	304
7.1 Incompatibilities with ChileSPICE. . . . .	307
8.1 Issues for Microsoft Windows. . . . .	309
9.1 Xyce ascii rawfile format. . . . .	312
9.2 Xyce binary rawfile format. . . . .	312

# 1. Introduction

---

## Welcome to **Xyce**

The **Xyce** Parallel Electronic Simulator has been written to support, in a rigorous manner, the simulation needs of the Sandia National Laboratories electrical designers. It is targeted specifically to run on large-scale parallel computing platforms but also runs well on a variety of architectures including single processor workstations. It also aims to support a variety of devices and models specific to Sandia needs.

## 1.1 Overview

This document is intended to complement the **Xyce** Users' Guide [1]. It contains comprehensive, detailed information about a number of topics pertinent to the usage of **Xyce**. Included in this document is a netlist reference for the input-file commands and elements supported within **Xyce**; a command line reference, which describes the available command line arguments for **Xyce**; and quick-references for users of other circuit codes, such as Orcad's PSpice [2] and Sandia's ChileSPICE.

## 1.2 How to Use this Guide

This guide is designed so you can quickly find the information you need to use **Xyce**. It assumes that you are familiar with basic Unix-type commands, how Unix manages applications and files to perform routine tasks (e.g., starting applications, opening files and saving your work). Note that while Windows versions of **Xyce** are available, they are command-line programs meant to be run under the "Command Prompt," and are used almost identically to their Unix counterparts.

### Typographical conventions

Before continuing in this Reference Guide, it is important to understand the terms and typographical conventions used. Procedures for performing an operation are generally numbered with the following typographical conventions.

Notation	Example	Description
Typewriter text	xmpirun -np 4	Commands entered from the keyboard on the command line or text entered in a netlist.
<b>Bold Roman Font</b>	Set nominal temperature using the TNOM option.	SPICE-type parameters used in models, etc.
Gray Shaded Text	DEBUGLEVEL	Feature that is designed primarily for use by Xyce developers.
[text in brackets]	Xyce [options] <netlist>	Optional parameters.
<text in angle brackets>	Xyce [options] <netlist>	Parameters to be inserted by the user.
<object with asterisk>*	K1 <ind. 1> [<ind. n>*]	Parameter that may be multiply specified.
<TEXT1 TEXT2>	.PRINT TRAN + DELIMITER=<TAB COMMA>	Parameters that may only take specified values.

**Table 1.1.** Xyce typographical conventions.

## 1.3 Third Party License Information

Portions of the new DAE time integrator contained in the BackwardDifferentiation15 source and include files are derived from the IDA code from Lawrence Livermore National Laboratories and is licensed under the following license.

Copyright (c) 2002, The Regents of the University of California.  
Produced at the Lawrence Livermore National Laboratory.  
Written by Alan Hindmarsh, Allan Taylor, Radu Serban.  
UCRL-CODE-2002-59  
All rights reserved.

This file is part of IDA.

Redistribution and use in source and binary forms, with or without modification, are permitted provided that the following conditions are met:

1. Redistributions of source code must retain the above copyright notice, this list of conditions and the disclaimer below.
2. Redistributions in binary form must reproduce the above copyright notice, this list of conditions and the disclaimer (as noted below) in the documentation and/or other materials provided with the distribution.
3. Neither the name of the UC/LLNL nor the names of its contributors may be used to endorse or promote products derived from this software without specific prior written permission.

THIS SOFTWARE IS PROVIDED BY THE COPYRIGHT HOLDERS AND CONTRIBUTORS "AS IS" AND ANY EXPRESS OR IMPLIED WARRANTIES, INCLUDING, BUT NOT LIMITED TO, THE IMPLIED WARRANTIES OF MERCHANTABILITY AND FITNESS FOR A PARTICULAR PURPOSE ARE DISCLAIMED. IN NO EVENT SHALL THE REGENTS OF THE UNIVERSITY OF CALIFORNIA, THE U.S. DEPARTMENT OF ENERGY OR CONTRIBUTORS BE LIABLE FOR ANY DIRECT, INDIRECT, INCIDENTAL, SPECIAL, EXEMPLARY, OR CONSEQUENTIAL DAMAGES (INCLUDING, BUT NOT LIMITED TO, PROCUREMENT OF SUBSTITUTE GOODS OR SERVICES; LOSS OF USE,

DATA, OR PROFITS; OR BUSINESS INTERRUPTION) HOWEVER CAUSED AND ON ANY THEORY OF LIABILITY, WHETHER IN CONTRACT, STRICT LIABILITY, OR TORT (INCLUDING NEGLIGENCE OR OTHERWISE) ARISING IN ANY WAY OUT OF THE USE OF THIS SOFTWARE, EVEN IF ADVISED OF THE POSSIBILITY OF SUCH DAMAGE.

Additional BSD Notice  
-----

1. This notice is required to be provided under our contract with the U.S. Department of Energy (DOE). This work was produced at the University of California, Lawrence Livermore National Laboratory under Contract No. W-7405-ENG-48 with the DOE.
  
2. Neither the United States Government nor the University of California nor any of their employees, makes any warranty, express or implied, or assumes any liability or responsibility for the accuracy, completeness, or usefulness of any information, apparatus, product, or process disclosed, or represents that its use would not infringe privately-owned rights.
  
3. Also, reference herein to any specific commercial products, process, or services by trade name, trademark, manufacturer or otherwise does not necessarily constitute or imply its endorsement, recommendation, or favoring by the United States Government or the University of California. The views and opinions of authors expressed herein do not necessarily state or reflect those of the United States Government or the University of California, and shall not be used for advertising or product endorsement purposes.



# 2. Netlist Reference

---

## Chapter Overview

This chapter contains reference material directed towards working with circuit analyses in **Xyce** using the netlist interface. Included are detailed command descriptions, start-up option definitions and a list of devices supported by the **Xyce** netlist interface.

## 2.1 Netlist Commands

This section outlines the netlist commands that can be used with **Xyce** to setup and control circuit analysis.

### DC Sweep Analysis

Calculates the operating point for the circuit for a range of values. Primarily, this capability is applied to independent voltage sources, but it can also be applied to most device parameters. Note that this may be repeated for multiple sources in the same `.DC` line.

The `.DC` command can specify a linear sweep, decade logarithmic sweep, octave logarithmic sweep, or a list of values.

Parameter	Description	Meaning
<b>LIN</b>	linear sweep	The sweep variable is swept linearly from the starting to the ending value.
<b>OCT</b>	sweep by octaves	Sweep by octaves. The sweep variable is swept logarithmically by octaves.
<b>DEC</b>	sweep by decades	Sweep by decades. The sweep variable is swept logarithmically by decades.
<b>LIST</b>	list of values	Use a list of values.

### Linear Sweeps

---

**General Form**      `.DC [LIN] <sweep variable name> <start> <stop> <step>`  
                          `+ [<sweep variable name> <start> <stop> <step>]...`

---

---

```
.DC LIN V1 5 25 5
```

**Examples**

```
.DC VIN -10 15 1
```

```
.DC R1 0 3.5 0.05 C1 0 3.5 0.5
```

---

## Decade Sweeps

**General Form**

```
.DC DEC <sweep variable name> <start> <stop> <points>
+ [DEC <sweep variable name><start> <stop> <points>]...
```

---

**Examples**

```
.DC DEC VIN 1 100 2
```

```
.DC DEC R1 100 10000 3 DEC VGS 0.001 1.0 2
```

---

## Octave Sweeps

**General Form**

```
.DC OCT <sweep variable name> <start> <stop> <points>
+ [OCT <sweep variable name><start> <stop> <points>]...
```

---

**Examples**

```
.DC OCT VIN 0.125 64 2
```

```
.DC OCT R1 0.015625 512 3 OCT C1 512 4096 1
```

---

## List Sweeps

---

**General Form**

```
.DC <sweep variable name> LIST <val> <val> <val> ...  
+ [<sweep variable name> LIST <val> <val> ...]...
```

---

**Examples**

```
.DC VIN LIST 1.0 2.0 5.0 6.0 10.0  
.DC VDS LIST 0 3.5 0.05 VGS LIST 0 3.5 0.5  
.DC TEMP LIST 10.0 15.0 18.0 27.0 33.0
```

---

## STEP Parametric Analysis

Calculates a full analysis (.DC or .TRAN) over a range of parameter values. This type of analysis is very similar to .DC analysis. Similar to .DC analysis, .STEP supports sweeps which are linear, decade logarithmic, octave logarithmic, or a list of values.

Parameter	Description	Meaning
<b>LIN</b>	linear sweep	The sweep variable is swept linearly from the starting to the ending value.
<b>OCT</b>	sweep by octaves	Sweep by octaves. The sweep variable is swept logarithmically by octaves.
<b>DEC</b>	sweep by decades	Sweep by decades. The sweep variable is swept logarithmically by decades.
<b>LIST</b>	list of values	Use a list of values.

### Linear Sweeps

#### General Form

```
.STEP <parameter name> <initial> <final> <step>
```

#### Examples

```
.STEP TEMP -45 -55 -10
```

```
.STEP R1 45 50 5
```

```
.STEP C101:C 45 50 5
```

```
.STEP DLEAK:IS 1.0e-12 1.0e-11 1.0e-12
```

```
.STEP V1 20 10 -1
```

---

<initial>

Initial value for the parameter.

**Arguments  
and Options**

<final>

Final value for the parameter.

<step>

Value that the parameter is incremented at each step.

---

STEP parameter analysis will sweep a parameter from its initial value to its final value, at increments of the step size. At each step of this sweep, it will conduct a full analysis (.DC or .TRAN) of the circuit.

The specification is similar to that of a .DC sweep, except that each parameter gets its own .STEP line in the input file, rather than specifying all of them on a single line.

**Comments**

Output, as designated by a .PRINT statement, is slightly more complicated in the case of a .STEP simulation. If the user has specified a .PRINT line in the input file, Xyce will output two files. All steps of the sweep to a single output file as usual, but with the results of each step appearing one after another with the "Index" column starting over at zero. Additionally, a file with a ".res" suffix will be produced indicating what parameters were used for each iteration of the step loops.

This is a similar capability to that of PSPICE and ChileSPICE, but not identical. In future releases, this capability will be fully compatible.

---

## Decade Sweeps

---

**General Form**

```
.STEP DEC <sweep variable name> <start> <stop> <points>
```

---

**Examples**

```
.STEP DEC VIN 1 100 2  
.STEP DEC R1 100 10000 3  
.STEP DEC TEMP 1.0 10.0 3
```

---

## Octave Sweeps

---

**General Form**

```
.STEP OCT <sweep variable name> <start> <stop> <points>
```

---

**Examples**

```
.STEP OCT VIN 0.125 64 2  
.STEP OCT TEMP 0.125 16.0 2  
.STEP OCT R1 0.015625 512 3
```

---

## List Sweeps

---

**General Form**

```
.STEP <sweep variable name> LIST <val> <val> <val> ...  
+ [<sweep variable name> LIST <val> <val> ...]...
```

---

---

**Examples**

```
.STEP VIN LIST 1.0 2.0 10. 12.0
```

```
.STEP TEMP LIST 8.0 21.0
```

---

## Transient Analysis

Calculates the time-domain response of a circuit for a specified duration.

---

### **General Form**

```
.TRAN <print step value> <final time value>  
+ [<start time value> [<step ceiling value>]] [NOOP] [UIC]  
+ [{schedule( <time>, <maximum time step>, ... )}]
```

---

### **Examples**

```
.TRAN 1us 100ms  
  
.TRAN 1ms 100ms 0ms .1ms  
.TRAN 0 2.0e-3 schedule( 0.5e-3, 0, 1.0e-3, 1.0e-6, 2.0e-3, 0 )
```

---

---

<print step value>

Used to calculate the initial time step (see below).

<final time value>

Sets the end time (duration) for the analysis.

[<start time value>]

Sets the time at which output of the simulation results is to begin. Defaults to zero.

**Arguments**  
**and Options**

[<step ceiling value>]

Sets a maximum time step. Defaults to ((final time value)-(start time value))/10, unless there are breakpoints (see below).

[NOOP]

Specifies that no operating point calculation is to be performed.

[UIC]

Specifies that no operating point calculation is to be performed, and that the specified initial condition (from .IC lines) should be used in its place.

```
[{schedule( <time>, <maximum time step>, ... )}]
```

### Arguments and Options

Specifies a schedule for maximum allowed time steps. The list of arguments,  $t_0$ ,  $\Delta t_0$ ,  $t_1$ ,  $\Delta t_1$ , *etc.* implies that a maximum time step of  $\Delta t_0$  will be used while the simulation time is greater than or equal to  $t_0$  and less than  $t_1$ . A maximum time step of  $\Delta t_1$  will be used when the simulation time is greater or equal to than  $t_1$  and less than  $t_2$ . This sequence will continue for all pairs of  $t_i$ ,  $\Delta t_i$  that are given in the {schedule()}. If  $\Delta t$  is zero or negative, then no maximum time step is enforced (other than hardware limits of the host computer).

---

The transient analysis calculates the circuit's response over an interval of time beginning with TIME=0 and finishing at <final time value>. Use a .PRINT (print) statement to get the results of the transient analysis.

Before calculating the transient response **Xyce** computes a bias point for the circuit that is different from the regular bias point. This is necessary because at the start of a transient analysis, the independent sources can have different values than their DC values. Specifying NOOP on the .TRAN line causes **Xyce** to begin the transient analysis without performing the usual bias point calculation.

### Comments

The time integration algorithms within **Xyce** use adaptive time-stepping methods that adjust the time-step size according to the activity in the analysis. The default ceiling for the internal time step is ( $\text{<final time value> - <start time value>}$ )/10. This default ceiling value is automatically adjusted if breakpoints are present, to insure that there are always at least 10 time steps between breakpoints. If the user specifies a ceiling value, however, it overrides any internally generated ceiling values.

**Xyce** is not strictly compatible with SPICE in its use of the values on the .TRAN line. In **Xyce**, <print step value> is not used as the printing interval. It is used in determining the initial step size, which is chosen to be the smallest of three quantities: the print step value, the step ceiling value, and 1/200th of the time until the next breakpoint.

The third argument to .TRAN simply determines the earliest time for which results are to be output. Simulation of the circuit always begins at TIME=0 irrespective of the setting of <start time value>.

---

## Harmonic Balance Analysis

Calculates steady states of nonlinear circuits in the frequency domain.

---

**General Form**      `.HB <fundamental frequency>`

---

**Examples**            `.HB 1e4`

---

**Arguments**            `<fundamental frequency>`

**and Options**

     Sets the fundamental frequency for the analysis.

---

**Comments**            Harmonic balance analysis calculates the magnitude and phase of voltages and currents in a nonlinear circuit. Use a `.PRINT` (print) statement to get the results of the harmonic balance analysis.

---

## Multi-Time Partial Differential Equation (MPDE) Analysis

Calculates the time-domain response of a circuit with two disparate time scales.

---

**General Form**      .MPDE <print step value> <final time value>

---

**Examples**            .MPDE 1us 100ms

---

<print step value>

**Arguments  
and Options**            Used to calculate the initial time step (see .tran).  
  
                                 <final time value>

                                 Sets the end time (duration) for the analysis.

---

**Comments**

---

## Device Modeling

### .MODEL (Model Definition)

Modeled device definition.

### .SUBCKT (subcircuit)

The .SUBCKT statement begins a subcircuit definition by giving its name, the number and order of its nodes and the names and default parameters that direct its behavior. The .ENDS statement signifies the end of the subcircuit definition.

---

#### **General Form**

```
.SUBCKT <name> [node]*
+ [PARAMS: < <name> = <value> >* ]
...
.ENDS
```

---

#### **Examples**

```
.SUBCKT OPAMP 10 12 111 112 13
...
.ENDS

.SUBCKT FILTER1 INPUT OUTPUT PARAMS: CENTER=200kHz,
+ BANDWIDTH=20kHz
...
.ENDS

.SUBCKT PLRD IN1 IN2 IN3 OUT1
+ PARAMS: MNTYMXDELY=0 IO_LEVEL=1
...
.ENDS

.SUBCKT 74LS01 A B Y
+ PARAMS: MNTYMXDELY=0 IO_LEVEL=1
...
.ENDS
```

---

---

<name>

The name used to reference a subcircuit.

[node]\*

An optional list of nodes. This is not mandatory since it is feasible to define a subcircuit without any interface nodes.

**Arguments**  
**and Options**

[PARAMS:]

Keyword that provides values to subcircuits as arguments for use as expressions in the subcircuit. Parameters defined in the PARAMS: section may be used in expressions within the body of the subcircuit and will take the default values specified in the subcircuit definition unless overridden by a PARAMS: section when the subcircuit is instantiated.

---

---

A subcircuit designation ends with a `.ENDS` command. The entire netlist between `.SUBCKT` and `.ENDS` is part of the definition. Each time the subcircuit is called via an `X` device, the entire netlist in the subcircuit definition replaces the `X` device.

There must be an equal number of nodes in the subcircuit call and in its definition. As soon as the subcircuit is called, the actual nodes (those in the calling statement) substitute for the argument nodes (those in the defining statement).

Node zero cannot be used in this node list, as it is the global ground node.

Subcircuit references may be nested to any level. Subcircuits definitions may also be nested; a `.SUBCKT` statement and its closing `.ENDS` may appear between another `.SUBCKT/.ENDS` pair. A subcircuit defined inside another subcircuit definition is local to the outer subcircuit and may not be used at higher levels of the circuit netlist.

Subcircuits should include only device instantiations and possibly these statements:

#### Comments

- `.MODEL` (model definition)
- `.PARAM` (parameter)
- `.FUNC` (function)

Models, parameters, and functions defined within a subcircuit are scoped to that definition. That is they are only accessible within the subcircuit definition in which they are included. Further, if a `.MODEL`, `.PARAM` or a `.FUNC` statement is included in the main circuit netlist, it is accessible from the main circuit as well as all subcircuits.

Node, device, and model names are scoped to the subcircuit in which they are defined. It is allowable to use a name in a subcircuit that has been previously used in the main circuit netlist. When the subcircuit is flattened (expanded into the main netlist), all of its names are given a prefix via the subcircuit instance name. For example, `Q17` becomes `X3:Q17` after expansion. After expansion, all names are unique. The single exception occurs in the use of global node names, which are not expanded.

---

`.ENDS` (end subcircuit)

Marks the end of a subcircuit definition.

## Output Control

### .MEASURE (measure)

The .MEASURE statement allows calculation or reporting of simulation metrics to an external file. One can measure when simulated signals reach designated values or equal other simulation values. The syntax for a .MEASURE statement is as follows:

---

**General Form**    .MEASURE <analysis type> resultName WHEN outVar = <outVar2|value>  
                  + [TD=value] [RISE=r|LAST] [FALL=f|LAST] [CROSS=c|LAST]  
                  + [GOAL=value] [MINVAL=value] [WEIGHT=value]

---

```
VS 1 0 SIN(0 1.0 1KHZ 0 0)
R1 1 0 100
```

### Examples

```
.measure tran hit1_75 when v(1)=0.75 minval=0.02
.measure tran hit2_75 when v(1)=0.75 minval=0.08 rise=2

.PRINT TRAN V(1) V(2)
.TRAN 0 10ms 1ms
.END
```

---

---

<analysis type>

Currently, only one analysis type, TRAN, is supported.

resultName

Measured results are reported to the output and log file. Additionally results are stored in a file called `circuitFileName.mt#` where the suffixed number starts at 0 and increases for multiple iterations of a given simulation. Each line of this file will contain the measurement name, `resultName` followed by its value for that run.

outVar = <outVar2|value>

This represents the test for the stated measurement. `outVar` is a simulation quantity such as a voltage or current. One can compare it to another simulation variable or a fixed quantity.

TD=value

A time delay before which this measurement should be taken or checked.

### Arguments and Options

RISE=r|LAST

The number of rises after which the measurement should be checked. If `LAST` is specified, then the last rise found in the simulation will be used.

FALL=f|LAST

The number of falls after which the measurement should be checked. If `LAST` is specified, then the last fall found in the simulation will be used.

CROSS=c|LAST

The number of zero crossings after which the measurement should be checked. If `LAST` is specified, then the last zero crossing found in the simulation will be used.

MINVALUE=value

An allowed absolute difference between `outVal` and the variable to which it is being compared. This has a default value of `1.0e-12`. One may need to specify a larger value to avoid missing the test condition in a transient run.

GOAL=value

**Arguments**

This parameter is reserved for optimization and will be used in future versions of **Xyce**

**and Options**

*continued*

WEIGHT=value

This parameter is reserved for optimization and will be used in future versions of **Xyce**

**.PRINT (print)**

Send analysis results to an output file. **Xyce** supports several options on the .PRINT line of netlists:

**General Form**

```
.PRINT <analysis type> [FORMAT=<STD|NOINDEX|PROBE|TECPLOT|RAW|CSV>]
+ [FILE=<output filename>] [WIDTH=<print field width>]
+ [PRECISION=<floating point output precision>]
+ [FILTER=<absolute value below which a number outputs as 0.0>]
+ [DELIMITER=<TAB|COMMA>] [TIMESCALEFACTOR=<real scale factor>]
+ <output variable>
```

```
.print tran format=tecplot V(1) I(Vsrc) {V(1)*(I(Vsrc)**2.0)}  
.PRINT TRAN FORMAT=PROBE FILE=foobar.csd V(1) {abs(V(1))-5.0}  
.PRINT DC FILE=foobar.txt WIDTH=19 PRECISION=15 FILTER=1.0e-10  
+ I(VSOURCE5) I(VSOURCE6)
```

**Examples**

```
.print tran FORMAT=RAW V(1) I(Vsrc)  
  
R1 1 0 100  
X1 1 2 3 MySubcircuit  
V1 3 0 1V  
.SUBCKT MYSUBCIRCUIT 1 2 3  
R1 1 2 100K  
R2 2 4 50K  
R3 4 3 1K  
.ENDS  
.PRINT DC V(X1:4) V(2) I(V1)
```

---

---

<analysis type>

Only one analysis type (DC or TRAN) may be given for each .PRINT netlist entry.

[FORMAT=<STD | NOINDEX | PROBE | TECPLOT | RAW | CSV>]

The output format may be specified using the FORMAT option. The STD format outputs the data divided up into data columns. The NOINDEX format is the same as the STD format except that the index column is omitted. The PROBE format specifies that the output should be formatted to be compatible with the PSpice Probe plotting utility. The TECPLOT format specifies that the output should be formatted to be compatible with the Tecplot plotting program. The RAW format specifies that the output should comply with the Spice binary rawfile format. Use with the **-a** command line option to output an ascii rawfile. The CSV format specifies that the output file should be a comma-separated value file with a header indicating the variables printed in the file. It is similar to, but not identical to using DELIMITER=COMMA; the latter will also print a footer that is not compatible with most software that requires CSV format.

### **Arguments and Options**

[FILE=<output filename>]

Specifies the name of the file to which the output will be written.

[WIDTH=<print field width>]

Controls the output width used in formatting the output.

[PRECISION=<floating point precision >]

Number of floating point digits past the decimal for output data.

[FILTER=<filter floor value>]

Used to specify the absolute value below which output variables will be printed as 0.0.

[DELIMITER=<TAB | COMMA>]

Used to specify an alternate delimiter in the STD or NOINDEX format output.

TIMESCALEFACTOR=<real scale factor>

Specify a constant scaling factor for time. Time is normally printed in units of seconds, but if one would like the units to be milliseconds, then set TIMESCALEFACTOR=1000.

---

---

<output variable>

Following the analysis type and other options is a list of output variables. There is no upper bound on the number of output variables. The output is divided up into data columns and output according to any specified options (see options given above). Output variables can be specified in four ways:

**Arguments**  
**and Options**  
*continued*

- V(<circuit node>) to output the voltage at a point in the circuit
- I(<device>) to output current through a two terminal device.
- I<lead abbreviation>(<device>) to output current into a particular lead of a three or more terminal device.
- {expression} to output an expression involving V and I values.

Further explanation of current specification is in comments section below.

---

---

**Comments**

Currents are positive flowing from node 1 to node 2 for two node devices, and currents are positive flowing into a particular lead for leads. <circuit node> is simply the name of any node in your top-level circuit, or <subcircuit name>:<node> to reference nodes that are internal to a subcircuit. <device> is the name of any device in your top-level circuit, or <subcircuit name>:<device> to reference devices that are internal to a subcircuit. <lead abbreviation> is a single character designator for individual leads on a device with three or more leads. For bipolar transistors these are: c (collector), b (base), e (emitter), s (substrate). For mosfets, lead abbreviations are: d (drain), g (gate), s (source), and b (bulk). SOI transistors have: d, g, s, e (bulk), and b (body). For PDE devices, the nodes are numbered according to the order they appear, so lead currents are referenced like i1(<device>), i2(<device>), etc.

The values of the output variables are output as a series of columns (one for each output variable). Note that while the .PRINT line supports expressions, .PRINT line expressions do not recognize .PARAM specified parameters. For example, this .PRINT line:

```
.PARAM tmpval=0.33
R1 0 1 tmpval
.PRINT TRAN V(1) {tmpval*V(1)}
```

will fail with an error saying that tmpval is not recognized in the .PRINT expression.

---

## Netlist Processing

### .END (End of Circuit)

End of netlist file.

### .FUNC (function)

User defined functions that can be used in expressions appearing later in the same scope as the .FUNC statement.

---

#### **General Form**

.FUNC <name>([arg]\*) <body>

---

#### **Examples**

```
.FUNC E(x) {exp(x)}
.FUNC DECAY(CNST) {E(-CNST*TIME)}
.FUNC TRIWAV(x) {ACOS(COS(x))/3.14159}
.FUNC MIN3(A,B,C) {MIN(A,MIN(B,C))}
```

---

.FUNC

Must precede the first use of the function name. Functions cannot be redefined and the function name must not be the same as any of the predefined functions (e.g., SIN and Sqrt). .FUNC arguments cannot be node names.

#### **Arguments**

<body>

#### **and Options**

May refer to other (previously defined) functions; the second example, DECAY, uses the first example, E.

[arg]

The number of arguments in the use of a function must agree with the number in the definition. Parameters, TIME, and other functions are allowed in the body of function definitions.

---

#### **Comments**

The <body> of a defined function is handled in the same way as any math expression; it must be enclosed in curly braces .

---

### .INC or .INCLUDE (include file)

Include specified file in netlist.

The file name can be surrounded by double quotes, "filename", but this is not necessary. The directory for the include file is assumed to be the execution directory unless a full or relative path is given as a part of the file name.

### .LIB (library file) (section name)

Include all blocks denoted by the section name of the specified library file.

The library file name can be surrounded by double quotes, as in "path/filename" but this is not necessary. The directory for the library file is assumed to be the execution directory unless a full or relative path is given as a part of the file name. The section name denotes the section or sections of the library file to include. For example if the section name is `nominal` then all netlist commands between the statements

```
.LIB nominal
```

```
.ENDL
```

would be parsed for a given simulation. Any lines not surrounded by a `.LIB section-name, .ENDL` in a library file will always be parsed for a given simulation.

### .PARAM (parameter)

User defined parameter that can be used in expressions throughout the netlist.

---

#### **General Form**

```
.PARAM [<name>=<value>]*
```

---

#### **Examples**

```
.PARAM A_Param=1K  
.PARAM B_Param={A_Param*3.1415926535}
```

---

---

<b><u>Comments</u></b>	Parameters defined using <code>.PARAM</code> are evaluated when the netlist is read in, and therefore must evaluate to constants at the time the netlist is parsed. It is therefore illegal to use any time- or solution-dependent terms in parameter definitions, including the <code>TIME</code> variable or any nodal voltages. Since they must be constants, these parameters may also not be used in <code>.STEP</code> loops.
------------------------	---

---

### `.GLOBAL_PARAM` (global parameter)

User defined global parameter that can be time dependent, or that can be used in `.STEP` loops.

---

<b><u>General Form</u></b>	<code>.GLOBAL_PARAM [&lt;name&gt;=&lt;value&gt;]*</code>
----------------------------	--

---

<b><u>Examples</u></b>	<code>.GLOBAL_PARAM T={27+100*time}</code>
------------------------	--

---

<b><u>Comments</u></b>	<p>You may use parameters defined by <code>.PARAM</code> in expressions used to define global parameters, but you may <i>not</i> use global parameters in <code>.PARAM</code> definitions.</p> <p>Unlike <code>.PARAM</code> parameters, global parameters are evaluated at the time they are needed and may therefore be time dependent and may depend on other time dependent quantities in the circuit.</p> <p>Global parameters are accessible and have the same value throughout all levels of the netlist hierarchy. It is not legal to redefine global parameters in different levels of the netlist hierarchy.</p>
------------------------	--

---

## Miscellaneous Commands

### \* (Comment)

Create a netlist comment line.

### ; (In-line Comment)

Add a netlist in-line comment

## + (Line Continuation)

Continue the text of the previous line

## .OPTIONS Statements

### .OPTIONS (Analysis Options)

Set various simulation limits, analysis control parameters and output characters. In general, they use the following format:

```
.OPTIONS <PKG> [<TAG>=<VALUE>]*
```

Exceptions to this format include the `OUTPUT` and `RESTART` options that use their own format, which will be defined under their respective descriptions.

The designator `PKG` refers to the Unified Modeling Language (UML) *package* which refers loosely to a *module* in the code. Thus, the term is used here as identifying a specific *module* to be controlled via *options* set in the netlist input file. The packages which currently support `.OPTIONS`, and the keywords to use in place of `<PKG>` are:

Package	PKG keyword
Global:	GLOBAL
Device Model:	DEVICE
Time Integration:	TIMEINT
Nonlinear Solver:	NONLIN
Transient Nonlinear Solver:	NONLIN-TRAN
Continuation/Bifurcation Tracking:	LOCA
Linear Solver:	LINSOL
Output:	OUTPUT
Restart:	RESTART
MPDE:	MPDEINT
Harmonic Balance:	HBINT

As an example, the following netlist line will set the value of ABSTOL in the time integration package to  $1 \times 10^{-8}$ :

**Example:**            .OPTIONS TIMEINT ABSTOL=1E-8

Below is an outline of the supported packages and their respective options:

### Device Package Options

The device package parameters listed in Table 2.1 outline the options available for specifying device specific parameters. Some of these (DEFAS, DEFAD, TNOM etc.) have the same meaning as they do for the .OPTION line from Berkeley SPICE (3f5). Parameters which apply globally to all device models will be specified here. Parameters specific to a particular device instance or model are specified in section 2.2.

Device Model (PKG = DEVICE) Tag	Description	Default
DEFAS	MOS Drain Diffusion Area	0.0
DEFAD	MOS Source Diffusion Area	0.0
DEFL	MOS Default Channel Length	1.0E-4
DEFW	MOS Default Channel Width	1.0E-4
GMIN	Minimum Conductance	1.0E-12
MINRES	Lead resistance for semiconductor device leads specified as zero	0.0
MINCAP	Capacitance to use for semiconductor junction capacitance specified as zero	0.0
TEMP	Temperature	27.0 °C (300.15K)
TNOM	Nominal Temperature	27.0 °C (300.15K)
NUMJAC	Numerical Jacobian flag (only use for small problems)	0 (FALSE)
VOLTLIM	Voltage limiting	1 (TRUE)

Device Model (PKG = DEVICE) Tag	Description	Default
icFac	This is a multiplicative factor which is applied to right-hand side vector loads of .IC initial conditions during the DCOP phase.	10000.0
LAMBERTW	This flag determines if the Lambert-W function should be applied in place of exponentials in hard-to-solve devices. Currently, this capability is implemented in the diode and BJT. Try this for BJT circuits that have convergence problems. For best effect, this option should be tried with voltlim turned off. A detailed explanation of the Lambert-W function, and its application to device modeling can be found in reference [3].	0 (FALSE)
MAXTimestep	Maximum time step size	1.0E+99
<b><i>MOSFET Homtopy parameters</i></b>		
VDSSCALEMIN	Scaling factor for Vds	0.3
VGSTCONST	Initial value for Vgst	4.5 Volt
LENGTH0	Initial value for length	5.0e-6
WIDTH0	Initial value for width	200.0e-6
TOX0	Initial value for oxide thickness	6.0e-8
<b><i>Debug output parameters</i></b>		
DEBUGLEVEL	The higher this number, the more info is output	1
DEBUGMINTimestep	First time-step debug information is output	0

Device Model (PKG = DEVICE) Tag	Description	Default
DEBUGMAXTIMESTEP	Last time-step of debug output	65536
DEBUGMINTIME	Same as DEBUGMINTIMESTEP except controlled by time (sec.) instead of step number	0.0
DEBUGMAXTIME	Same as DEBUGMAXTIMESTEP except controlled by time (sec.) instead of step number	100.0

Table 2.1: Options for Device Package

### Time Integration Options

The time integration parameters listed in Table 2.2 give the available options for helping control the time integration algorithms for transient analysis.

Time Integration (PKG = TIMEINT) Tag	Description	Default
METHOD	Time integration method. This parameter is only relevant when running <b>Xyce</b> in transient mode. Supported methods: <ul style="list-style-type: none"> <li>■ 6 (Backward Difference Formula orders 1-5)</li> <li>■ 7 (variable order Trapezoid)</li> </ul>	6 (BDF 1-5)
RELTOL	Relative error tolerance	1.0E-02
ABSTOL	Absolute error tolerance	1.0E-06

Time Integration (PKG = TIMEINT) Tag	Description	Default
RESTARTSTEPSCALE	This parameter is a scalar which determines how small the initial time step out of a breakpoint should be. In the current version of the time integrator, the first step after a breakpoint isn't subjected to much error analysis, so for very stiff circuits, this step can be problematic.	0.005
NLNEARCONV	This flag sets if "soft" failures of the nonlinear solver, when the convergence criteria are almost, but not quite, met, should result in a "success" code being returned from the nonlinear solver to the time integrator. If this is enabled, it is expected that the error analysis performed by the time integrator will be the sole determination of whether or not the time step is considered a "pass" or a "fail". This is on by default, but occasionally circuits need tighter convergence criteria.	1 (TRUE)
NLSMALLUPDATE	This is another "soft" nonlinear solver failure flag. In this case, if the flag is set, time steps in which the nonlinear solver stalls, and is using updates that are numerically tiny, can be considered to have converged by the nonlinear solver. If this flag is set, the time integrator is responsible for determining if a step should be accepted or not.	1 (TRUE)
RESETTRANLS	The nonlinear solver resets its settings for the transient part of the run to something more efficient (basically a simpler set of options with smaller numbers for things like max Newton step). If this is set to false, this resetting is turned off. Normally should be left as default.	1 (TRUE)

Time Integration (PKG = TIMEINT) Tag	Description	Default
MAXORD	This parameter determines the maximum order of integration that the BDF 1-5 integrator will attempt. This can be reduced down to 1 to use Backward Euler and can be set at 2 when BDF 1-2 is desired. Setting this option does not guarantee that the integrator will integrate at this order, it just sets the maximum order the integrator will attempt. In order to guarantee a particular order is used, see the option MINORD below.	5
MINORD	This parameter determines the minimum order of integration that the BDF 1-5 integrator will attempt to maintain. The integrator will start at Backward Euler and move up in order as quickly as possible to achieve MINORD and then it will keep the order above this. If MINORD is set at 2 and MAXORD is set at 2, then the integrator will move to second order as quickly as possible and stay there. This mode closely approximates a fixed second-order BDF method.	1

Time Integration (PKG = TIMEINT) Tag	Description	Default
ERROPTION	<p>This parameter determines if Local Truncation Error (LTE) control is turned on or not. If ERROPTION is on, then step-size selection is based on the number of Newton iterations nonlinear solve. For BDF15, if the nonlinear solve succeeds, then the step is doubled, otherwise it is cut by one eighth. For Trapezoid, if the number of nonlinear iterations is below NLMIN then the step is doubled. If the number of nonlinear iterations is above NLMAX then the step is cut by one eighth. In between, the step-size is left alone. Because this option can lead to very large time-steps, it is very important to specify an appropriate DELMAX option. If the circuit has breakpoints, then the option MINTIMESTEPSBP can also help to adjust the maximum time-step by specifying the minimum number of time points between breakpoints.</p>	0 (Local Truncation Error is used)
NLMIN	<p>This parameter determines the lower bound for the desired number of nonlinear iterations during a Trapezoid time integration solve with ERROPTION=1.</p>	3
NLMAX	<p>This parameter determines the upper bound for the desired number of nonlinear iterations during a Trapezoid time integration solve with ERROPTION=1.</p>	8
DELMAX	<p>This parameter determines the maximum time step-size used with ERROPTION=1. If a maximum time-step is also specified on the .TRAN line, then the minimum of that value and DELMAX is used.</p>	1e99
MINTIMESTEPSBP	<p>This parameter determines the minimum number of time-steps to use between breakpoints. This enforces a maximum time-step between breakpoints equal to the distance between the last breakpoint and the next breakpoint divided by MINTIMESTEPSBP.</p>	10

Time Integration (PKG = TIMEINT) Tag	Description	Default
TIMESTEPSREVERSAL	<p>This parameter determines whether time-steps are rejected based upon the step-size selection strategy in ERROPTION=1. If it is set to 0, then a step will be accepted with successful nonlinear solves independent of whether the number of nonlinear iterations is between NLMIN and NLMAX. If it is set to 1, then when the number of nonlinear iterations is above NLMAX, the step will be rejected and the step-size cut by one eighth and retried. If ERROPTION=0 (use LTE) then TIMESTEPSREVERSAL=1 (reject steps) is set. This has the consequence that for the BDF15 integrator, TIMESTEPREVERSAL=1.</p>	<p>0 (do not reject steps)</p>
DOUBLED COPSTEP	<p>This option should only be set to TRUE for a PDE device run. PDE devices often have to solve an extra "setup" problem to get the initial condition. This extra setup problem solves a nonlinear Poisson equation (see the device appendix for more details), while the normal step solves a full drift-diffusion(DD) problem. The name of this flag refers to the fact that the code is essentially taking two DC operating point steps instead of one. If you set this to TRUE, but have no PDE devices in the circuit, the code will repeat the same identical DCOP step twice. Generally there is no point in doing this.</p>	<ul style="list-style-type: none"> <li>• 0 (FALSE), if no PDE devices are present.</li> <li>• 1 (TRUE), if at least one PDE device is in the circuit.</li> </ul>

Time Integration (PKG = TIMEINT) Tag	Description	Default
FIRSTDCOPSTEP	<p>This is the index of the first DCOP step taken in a simulation for which DOUBLED COPSTEP is set to TRUE. The special initialization (nonlinear Poisson) step is referred to as step 0, while the normal (drift-diffusion) step is indexed with a 1. These two options (FIRSTDCOPSTEP and LASTDCOPSTEP) allow you to set the 1st or second DCOP step to be either kind of step. If FIRSTDCOPSTEP and LASTDCOPSTEP are both set to 0, then only the initial setup step happens. If FIRSTDCOPSTEP and LASTDCOPSTEP are both set to 1, then the initialization step doesn't happen, and only the real DD problem is attempted, with a crude initial guess. You should <i>never</i> set FIRSTDCOPSTEP to 1 and SECONDDCOPSTEP to 0. Normally, they should always be left as the defaults.</p>	0
LASTDCOPSTEP	<p>This is the second step taken in a simulation for which DOUBLED COPSTEP is set to TRUE.</p>	1
BPENABLE	<p>Flag for turning on/off breakpoints (1 = ON, 0 = OFF). It is unlikely anyone would ever set this to FALSE, except to help debug the breakpoint capability.</p>	1 (TRUE)

Time Integration (PKG = TIMEINT) Tag	Description	Default
EXITTIME	If this is set to nonzero, the code will check the simulation time at the end of each step. If the total time exceeds the exittime, the code will ungracefully exit. This is a debugging option, the point of which is to have the code stop at a certain time during a run without affecting the step size control. If not set by the user, it isn't activated.	-
EXITSTEP	Same as EXITTIME, only applied to step number. The code will exit at the specified step. If not set by the user, it isn't activated.	-

Table 2.2: Options for Time Integration Package.

### Multi-Time Partial Differential Equation Options (MPDE)

**Xyce** has the ability to quickly simulate systems with two separated time scales, *i.e.* a *fast* and *slow* time scale. In this case, **Xyce** computes a set of solutions on the *fast* time scale and then tries to integrate this set of solutions forward in time along the *slow* time scale. Please see the **Xyce** Users' Guide for more information.

Multi-Time Partial Differential Equation Analysis (PKG = MPDEINT) Tag	Description	Default
N2	Number of time points in the fast time domain	20

Multi-Time Partial Differential Equation Analysis (PKG = MPDEINT) Tag	Description	Default
AUTON2	Do a one period initial transient run to determine the number and location of the fast time points.	false
AUTON2MAX	The maximum number of fast time points to keep from an initial transient run.	20
OSCSRC	A list of voltage or current sources which change on the fast time scale.	VIN
STARTUPPERIODS	The number of fast time periods to integrate through before calculating the MPDE initial conditions.	0
OSCOUT	Node for periodicity condition for Warped MPDE	
PHASE	Phase specification for Warped MPDE	0
PHASECOEFF	Phase coefficient for Warped MPDE	
T2	The time in seconds of the fast time period. This overrides any automatically determined period from OSCSRC.	0
WAMPDE	Flag specifying that this will be Warped MPDE calculation	false
FREQDOMAIN		
ICPER		
IC	Initial condition calculation method to use. Use 0 for Sawtooth or 1 for a transient run.	0

<b>Multi-Time Partial Differential Equation Analysis (PKG = MPDEINT) Tag</b>	<b>Description</b>	<b>Default</b>
DIFF	Differentiation scheme to use on the fast time scale. Use 0 for backwards difference and 1 for central differences.	0
DIFFORDER	Differentiation order for fast time scale time derivatives.	1

Table 2.3: Options for MPDE Package.

### Harmonic Balance Options

The Harmonic Balance parameters listed in Table 2.4 give the available options for helping control the harmonic balance algorithms for harmonic balance analysis.

<b>Harmonic balance Analysis (PKG = hbint) Tag</b>	<b>Description</b>	<b>Default</b>
numfreq	Number of harmonic frequencies to be calculated and it must be an odd number.	21
STARTUPPERIODS	The number of fast time periods to integrate through before calculating the initial conditions.	0

Table 2.4: Options for HB.

### Nonlinear Solver Options

The nonlinear solver parameters listed in Table 2.5 provide methods for controlling the nonlinear solver for DC, Transient and harmonic balance. Note that the nonlinear solver options for DCOP, transient and harmonic balance are specified in separate options statements, using .OPTIONS NONLIN, .OPTIONS NONLIN-TRAN and .OPTIONS NONLIN-HB, re-

spectively. The defaults for each are specified in the third and fourth columns of Table 2.5.

Nonlinear Solver (PKG = NONLIN) and (PKG = NONLIN-TRAN) Tags	Description	NONLIN Default	NONLIN-TRAN Default
NOX	Use NOX nonlinear solver.	1 (TRUE)	1 (TRUE)
NLSTRATEGY	Nonlinear solution strategy. Supported Strategies: <ul style="list-style-type: none"> <li>■ 0 (Newton)</li> <li>■ 1 (Gradient)</li> <li>■ 2 (Trust Region)</li> </ul>	0 (Newton)	0 (Newton)
SEARCHMETHOD	Line-search method used by the nonlinear solver. Supported line-search methods: <ul style="list-style-type: none"> <li>■ 0 (Full Newton - no line search)</li> <li>■ 1 (Interval Halving)</li> <li>■ 2 (Quadratic Interpolation)</li> <li>■ 3 (Cubic Interpolation)</li> <li>■ 4 (More'- Thuente)</li> </ul>	0 (Full Newton)  (NOTE: for iterative linear solves, the default is Quadratic Linesearch - 2)	0 (Full Newton)

Nonlinear Solver (PKG = NONLIN) and (PKG = NONLIN-TRAN) Tags	Description	NONLIN Default	NONLIN-TRAN Default
CONTINUATION	Enables the use of Homotopy/Continuation algorithms for the nonlinear solve. Options are: <ul style="list-style-type: none"> <li>■ 0 (Standard nonlinear solve)</li> <li>■ 1 (Natural parameter homotopy. See LOCA options list)</li> <li>■ 2 (Specialized dual parameter homotopy for MOSFET circuits)</li> </ul>	0 (Standard nonlinear solve)	0 (Standard nonlinear solve)
ABSTOL	Absolute residual vector tolerance	1.0E-12	1.0E-06
RELTOL	Relative residual vector tolerance	1.0E-03	1.0E-02
DELTAXTOL	Weighted nonlinear-solution update norm convergence tolerance	1.0	0.33
RHSTOL	Residual convergence tolerance (unweighted 2-norm)	1.0E-06	1.0E-02
SMALLUPDATETOL	Minimum acceptable norm for weighted nonlinear-solution update	1.0E-06	1.0E-06
MAXSTEP	Maximum number of Newton steps	200	20
MAXSEARCHSTEP	Maximum number of line-search steps	2	2
NORMLVL	Norm level used by the nonlinear solver algorithms ( <i>NOTE: not used for convergence tests</i> )	2	2

Nonlinear Solver (PKG = NONLIN) and (PKG = NONLIN-TRAN) Tags	Description	NONLIN Default	NONLIN-TRAN Default
IN_FORCING	Inexact Newton-Krylov forcing flag	0 (FALSE)	0 (FALSE)
AZ_TOL	Sets the minimum allowed linear solver tolerance. Valid only if IN_FORCING=1.	1.0E-12	1.0E-12
RECOVERYSTEPTYPE	<p>If using a line search, this option determines the type of step to take if the line search fails. Supported strategies:</p> <ul style="list-style-type: none"> <li>■ 0 (Take the last computed step size in the line search algorithm)</li> <li>■ 1 (Take a constant step size set by RECOVERYSTEP)</li> </ul>	0	0
RECOVERYSTEP	Value of the recovery step if a constant step length is selected	1.0	1.0
DLSDEBUG	Debug output for direct linear solver	0 (FALSE)	0 (FALSE)
DEBUGLEVEL	The higher this number, the more info is output	1	1

Nonlinear Solver (PKG = NONLIN) and (PKG = NONLIN-TRAN) Tags	Description	NONLIN Default	NONLIN-TRAN Default
DEBUGMINTIMESTEP	First time-step debug information is output	0	0
DEBUGMAXTIMESTEP	Last time-step of debug output	99999999	99999999
DEBUGMINTIME	Same as DEBUGMINTIMESTEP except controlled by time (sec.) instead of step number	0.0	0.0
DEBUGMAXTIME	Same as DEBUGMAXTIMESTEP except controlled by time (sec.) instead of step number	1.0E+99	1.0E+99
<b><i>Parameters not supported by NOX</i></b>			
LINOPT	Linear optimization flag	0 (FALSE)	0 (FALSE)
CONSTRAINTBT	Constraint backtracking flag	0 (FALSE)	0 (FALSE)
CONSTRAINTMAX	Global maximum setting for constraint backtracking	DBL_MAX (Machine Dependent Constant)	DBL_MAX
CONSTRAINTMIN	Global minimum setting for constraint backtracking	-DBL_MAX (Machine Dependent Constant)	-DBL_MAX

Nonlinear Solver (PKG = NONLIN) and (PKG = NONLIN-TRAN) Tags	Description	NONLIN Default	NONLIN-TRAN Default
CONSTRAINTCHANGE	Global percentage-change setting for constraint backtracking	sqrt(DBL_MAX) (Machine Dependent Constant)	sqrt(DBL_MAX)

Table 2.5: Options for Nonlinear Solver Package.

### Continuation and Bifurcation Tracking Package Options

The continuation selections listed in Table 2.6 provide methods for controlling continuation and bifurcation analysis. These override the defaults and any that were set simply in the continuation package. This option block is only used if the nonlinear solver or transient nonlinear solver enable continuation through the CONTINUATION flag.

Continuation and Bifurcation (PKG = LOCA) Tag	Description	Default
STEPPER	Stepping algorithm to use:  <ul style="list-style-type: none"> <li>■ 0 (Natural or Zero order continuation)</li> <li>■ 1 (Arc-length continuation)</li> </ul>	0 (Natural)
PREDICTOR	Predictor algorithm to use:  <ul style="list-style-type: none"> <li>■ 0 (Tangent)</li> <li>■ 1 (Secant)</li> <li>■ 2 (Random)</li> <li>■ 3 (Constant)</li> </ul>	0 (Tangent)

Continuation and Bifurcation (PKG = LOCA) Tag	Description	Default
STEPCONTROL	Algorithm used to adjust the step size between continuation steps: <ul style="list-style-type: none"> <li>■ 0 (Constant)</li> <li>■ 1 (Adaptive)</li> </ul>	0 (Constant)
CONPARAM	Parameter in which to step during a continuation run	VA:V0
INITIALVALUE	Starting value of the continuation parameter	0.0
MINVALUE	Minimum value of the continuation parameter	-1.0E20
MAXVALUE	Maximum value of the continuation parameter	1.0E20
BIFPARAM	Parameter to compute during bifurcation tracking runs	VA:V0
MAXSTEPS	Maximum number of continuation steps (includes failed steps)	20
MAXNLITERS	Maximum number of nonlinear iterations allowed (set this parameter equal to the MAXSTEP parameter in the NONLIN option block)	20
INITIALSTEPsize	Starting value of the step size	1.0
MINSTEPsize	Minimum value of the step size	1.0E20
MAXSTEPsize	Maximum value of the step size	1.0E-4
AGGRESSIVENESS	Value between 0.0 and 1.0 that determines how aggressive the step size control algorithm should be when increasing the step size. 0.0 is a constant step size while 1.0 is the most aggressive.	0.0

Table 2.6: Options for Continuation and Bifurcation Tracking Package.

### Linear Solver Options

Xyce uses both sparse-direct solvers as well as Krylov iterative methods for the solution of the linear equations generated by Newton’s method. For the advanced users, there are a variety of options that can be set to help improve these solvers. Many of these options (for the Krylov solvers) are simply passed through to the underlying Trilinos/AztecOO solution settings and thus have an “AZ\_” prefix on the flag; the “AZ\_” options are all case-sensitive. The list in Table 2.7 only provides a partial list of the more commonly used Trilinos/AztecOO options. For a full list of the available options, please see the Aztec User’s Guide [4] available for download at <http://www.cs.sandia.gov/CRF/aztec1.html>. However, for most users, the default options should prove adequate.

Linear Solver (PKG = LINSOL) Tag	Description	Default
type	<p>Determines which linear solver will be used.</p> <ul style="list-style-type: none"> <li>■ SUPERLU</li> <li>■ KLU</li> <li>■ AZTECOO</li> </ul> <p>Note that while SuperLU and KLU are available for parallel execution they will solve the linear system in serial. Therefore they will be useful for moderate problem sizes but will not scale in memory or performance for large problems</p>	<p>KLU (Serial) AZTECOO (Parallel)</p>
TR_partition	Perform load-balance partitioning on the linear system	0 (NONE, Serial) 2 (Isorropia, Parallel)
TR_partition_type	Type of load-balance partitioning on the linear system	”GRAPH”
TR_singleton_filter	Triggers use of singleton filter for linear system	0 (FALSE)
TR_amd	Triggers use of approximate minimum-degree (AMD) ordering for linear system	0 (FALSE, Serial) 1 (TRUE, Parallel)

Linear Solver (PKG = LINSOL) Tag	Description	Default
TR_global_btf	Triggers use of block triangular form (BTF) ordering for linear system, requires TR_amd=0 and TR_partition=0	0 (FALSE)
TR_reindex	Reindexes linear system parallel global indices in lexicographical order, recommended with singleton filter	1 (TRUE)
TR_solvermap	Triggers remapping of column indices for parallel runs, recommended with singleton filter	1 (TRUE)
<b><i>Iterative linear solver parameters</i></b>		
adaptive_solve	Triggers use of AztecOO adaptive solve algorithm for preconditioning of iterative linear solves	0 (FALSE)
use_aztec_precond	Triggers use of native AztecOO preconditioners for the iterative linear solves	0 (FALSE)
AZ_max_iter	Maximum number of iterative solver iterations	500
AZ_precond	AztecOO iterative solver preconditioner flag (used only when use_aztec_precond=1)	AZ_dom_decomp (14)
AZ_solver	Iterative solver type	AZ_gmres (1)
AZ_conv	Convergence type	AZ_r0 (0)
AZ_pre_calc	Type of precalculation	AZ_recalc (1)
AZ_keep_info	Retain calculation info	AZ_true (1)
AZ_orthog	Type of orthogonalization	AZ_modified (1)
AZ_subdomain_solve	Subdomain solution for domain decomposition preconditioners	AZ_ilut (9)
AZ_ilut_fill	Approximate allowed fill-in factor for the ILUT preconditioner	2.0

Linear Solver (PKG = LINSOL) Tag	Description	Default
AZ_drop	Specifies drop tolerance used in conjunction with LU or ILUT preconditioners	1.0E-03
AZ_reorder	Reordering type	AZ_none (0)
AZ_scaling	Type of scaling	AZ_none (0)
AZ_kspace	Maximum size of Krylov subspace	500
AZ_tol	Convergence tolerance	1.0E-12
AZ_output	Output level	AZ_none (0) 50 (if verbose build)
AZ_diagnostics	Diagnostic information level	AZ_none (0)
AZ_overlap	Schwarz overlap level for ILU preconditioners	0
AZ_rthresh	Diagonal shifting relative threshold for ILU preconditioners	1.0001
AZ_athresh	Diagonal shifting absolute threshold for ILU preconditioners	1.0E-04

Table 2.7: Options for Linear Solver Package.

## Output Options

The main purpose of the .OPTIONS OUTPUT command is to allow control of the output frequency of data to files specified by .PRINT TRAN commands. The format is:

```
.OPTIONS OUTPUT INITIAL_INTERVAL=<interval> [<t0> <i0> [<t1> <i1>...]]
```

where INITIAL\_INTERVAL=<interval> specifies the starting interval time for output and <tx> <ix> specifies later simulation times <tx> where the output interval will change to <ix>.

**Note:** In all recent versions of Xyce the solution is output at the exact intervals requested; this is done by interpolating the solution to the requested time points.

## Checkpointing and Restarting Options

The `.OPTIONS RESTART` command is used to control all checkpoint output and restarting.

■ Checkpointing command format:

```
.OPTIONS RESTART [PACK=<0|1>] JOB=<job prefix>
+ [INITIAL_INTERVAL=<initial interval time>
+ [<t0> <i0> [<t1> <i1>...]]]
```

`PACK=<0|1>` indicates whether the restart data will be byte packed or not. Parallel restarts must always be packed while currently Windows/MingW runs are always not packed. Otherwise, by default data will be packed unless explicitly specified. `JOB=<job prefix>` identifies the prefix for restart files. The actual restart files will be the job name with the current simulation time appended (e.g. `name1e-05` for `JOB=name` and simulation time `1e-05` seconds). Furthermore, `INITIAL_INTERVAL=<initial interval time>` identifies the initial interval time used for restart output. The `<tx> <ix>` intervals identify times `<tx>` at which the output interval (`ix`) should change. This functionality is identical to that described for the `.OPTIONS OUTPUT` command.

To generate checkpoints at every time step (default):

**Example:** `.OPTIONS RESTART JOB=checkpt`

To generate checkpoints every  $0.1 \mu s$ :

**Example:** `.OPTIONS RESTART JOB=checkpt INITIAL_INTERVAL=0.1us`

To generate unpacked checkpoints every  $0.1 \mu s$ :

**Example:** `.OPTIONS RESTART PACK=0 JOB=checkpt INITIAL_INTERVAL=0.1us`

To specify an initial interval of  $0.1 \mu s$ , at  $1 \mu s$  change to interval of  $0.5 \mu s$ , and at  $10 \mu s$  change to interval of  $0.1 \mu s$ :

**Example:**

```
.OPTIONS RESTART JOB=checkpt INITIAL_INTERVAL=0.1us 1.0us
+ 0.5us 10us 0.1us
```

To restart from an existing restart file, specify the file by either `FILE=<restart file name>` to explicitly use a restart file or by `JOB=<job name> START_TIME=<specified name>` to specify a file prefix and a specified time. The time must exactly match an output file time for the simulator to correctly identify the correct file. To continue generating restart output files, `INITIAL_INTERVAL=<interval>` and following intervals can be appended to the command in the same format as described above. New restart files will be packed according to the previous restart file read in. Here are several examples:

■ Restarting command format:

```
.OPTIONS RESTART <FILE=<restart file name> |
+ JOB=<job name> START_TIME=<time>>
+ [ INITIAL_INTERVAL=<interval> [<t0> <i0> [<t1> <i1> ...]]]
```

Example restarting from checkpoint file at 0.133  $\mu$ s:

**Example:** `.OPTIONS RESTART JOB=checkpt START_TIME=0.133us`

To restart from checkpoint file at 0.133  $\mu$ s:

**Example:** `.OPTIONS RESTART FILE=checkpt0.000000133`

Restarting from 0.133  $\mu$ s and continue checkpointing at 0.1  $\mu$ s intervals:

**Example:**

```
.OPTIONS RESTART FILE=checkpt0.000000133 JOB=checkpt_again
+ INITIAL_INTERVAL=0.1us
```

## Restart with two-level

Large parallel problems which involve power supply parasitics often require a two-level solve, in which different parts of the problem are handled separately. In most respects, restarting a two-level simulation is similar to restarting a conventional simulation. However, there are a few differences:

- When running with a two-level algorithm, **Xyce** requires (at least) two different input

files. In order to do a restart of a two-level **Xyce** simulation, it is necessary to have an `.OPTIONS RESTART` statement in each file.

- It is necessary for the statements to be consistent. For example, the output times must be exactly the same, meaning the initial intervals must be exactly the same.
- Currently, **Xyce** will *not* check to make sure that the restart options used in different files match, so it is up to the user to insure matching options.
- Finally, as each netlist that is part of a two-level solve will have its own `.OPTIONS RESTART` statement, that means that each netlist will generate and/or use its own set of restart files. As a result, the restart file name used by each netlist must be unique.

## .PREPROCESS Statements

### .PREPROCESS (Netlist Preprocessing)

Used to automatically augment a netlist to remove/add/change certain features before a **Xyce** simulation begins. Generally takes the form

```
.PREPROCESS <KEYWORD> <VALUE> [<VALUE>]*
```

We describe each of the three main functionalities of `.PREPROCESS` statements below

#### Ground Synonym Replacement

The purpose of ground synonym replacement is to treat nodes with the names `GND`, `GND!`, `GROUND`, etc. as synonyms for node 0. The general invocation is

```
.PREPROCESS REPLACEGROUND <BOOL>
```

where `<BOOL>` is either `TRUE` or `FALSE`. If `TRUE`, **Xyce** will treat all instances of `GND`, `GND!`, `GROUND`, etc. as synonyms for node 0 but, if `FALSE`, **Xyce** will treat these nodes as separate. Only one `.PREPROCESS REPLACEGROUND` statement is permissible in a given netlist file.

## Removal of Unused Components

If a given netlist file contains devices whose terminals are all connected to the same node (e.g., R2 1 1 1M), it may be desirable to remove such components from the netlist before simulation begins. This is the purpose of the command

```
.PREPROCESS REMOVEUNUSED [<VALUE>]
```

where <VALUE> is a list of components separated by commas. As an example, the command

```
.PREPROCESS REMOVEUNUSED R,C
```

will attempt to search for all resistors and capacitors in a given netlist file whose individual device terminals are connected to the same node and remove these components from the netlist before simulation ensues. A list of components which are currently supported for removal is given in Table 2.8. Note that for MOSFETS and BJTs, three terminals on each device (the gate, source, and drain in the case of a MOSFET and the collector, base, and emitter in the case of a BJT) must be the same for the device to be removed from the netlist. As before, only one .PREPROCESS REMOVEUNUSED line is allowed in a given netlist file.

Keyword	Device Type
C	Capacitor
D	Diode
I	Independent Current Source
L	Inductor
M	MOSFET
Q	BJT
R	Resistor
V	Independent Voltage Source

Table 2.8: List of keywords and device types which can be used in a .PREPROCESS REMOVEUNUSED statement.

## Adding Resistors to Dangling Nodes

We refer to a *dangling node* as a circuit node in one of the following two scenarios: either the node is connected to only one device terminal, and/or the node has no DC path to

ground. If several such nodes exist in a given netlist file, it may be desirable to automatically append a resistor of a specified value between the dangling node and ground. To add resistors to nodes which are connected to only one device terminal, one may use the command

```
.PREPROCESS ADDRESISTORS ONETERMINAL <VALUE1>
```

where <VALUE1> is the value of the resistor to be placed between nodes with only one device terminal connection and ground. For instance, the command

```
.PREPROCESS ADDRESISTORS ONETERMINAL 1G
```

will add resistors of value 1G between ground and nodes with only one device terminal connection and ground. The command

```
.PREPROCESS ADDRESISTORS NODCPATH <VALUE2>
```

acts similarly, adding resistors of value <VALUE2> between ground and all nodes which have no DC path to ground.

The `.PREPROCESS ADDRESISTORS` command is functionally different from either of the prior `.PREPROCESS` commands in the following way: while the other commands augment the netlist file for the current simulation, a `.PREPROCESS ADDRESISTORS` statement creates an auxiliary netlist file which explicitly contains a set of resistors that connect dangling nodes to ground. If the original netlist file containing a `.PREPROCESS ADDRESISTORS` statement is called `filename`, invoking **Xyce** on this file will produce a file `filename_xyce.cir` which contains the resistors that connect dangling nodes to ground. One can then run **Xyce** on this file to run a simulation in which the dangling nodes are tied to ground. Note that, in the original run on the file `filename`, **Xyce** will continue to run a simulation as usual after producing the file `filename_xyce.cir`, but this simulation will *not* include the effects of adding resistors between the dangling nodes and ground. Refer to the **Xyce** User's Guide for more detailed examples on the use of `.PREPROCESS ADDRESISTOR` statements.

Note that it is possible for a node to have one device terminal connection and, simultaneously, have no DC path to ground. In this case, if both a `ONETERMINAL` and `NODCPATH` command are invoked, only the resistor for the `ONETERMINAL` connection is added to the netlist; the `NODCPATH` connection is omitted.

As before, each netlist file is allowed to contain only one `.PREPROCESS ADDRESSISTORS ONETERMINAL` and one `.PREPROCESS ADDRESSISTORS NODCPATH` line each, or else **Xyce** will exit in error.

## 2.2 Analog Devices

**Xyce** supports many analog devices, including sources, subcircuits and behavioral models. This section serves as a reference for the analog devices supported by **Xyce**. Each device is described separately and includes the following information, if applicable:

- a description and an example of the correct netlist syntax.
- the matching model types and their description.
- the matching list of model parameters and associated descriptions.
- the corresponding and characteristic equations for the model (as required).
- references to publications on which the model is based.

You can also create models and macromodels using the `.MODEL` (model definition) and `.SUBCKT` (subcircuit) statements, respectively.

Please note that the characteristic equations are provided to give a general representation of the device behavior. The actual **Xyce** implementation of the device may be slightly different in order to improve, for example, the robustness of the device.

Table 2.9 gives a summary of the analog device types and the form of their netlist formats. Each of these is described below in detail.

Device Type	Designator Letter	Typical Netlist Format
Nonlinear Dependent Source (B Source)	B	B<name> <+ node> <- node> + <I or V>={<expression>}
Capacitor	C	C<name> <+ node> <- node> [model name] <value> + [IC=<initial value>]
Diode	D	D<name> <anode node> <cathode node> + <model name> [area value]

Device Type	Designator Letter	Typical Netlist Format
Voltage Controlled Voltage Source	E	E<name> <+ node> <- node> <+ controlling node> + <- controlling node> <gain>
Current Controlled Current Source	F	F<name> <+ node> <- node> + <controlling V device name> <gain>
Voltage Controlled Current Source	G	G<name> <+ node> <- node> <+ controlling node> + <- controlling node> <transconductance>
Current Controlled Voltage Source	H	H<name> <+ node> <- node> + <controlling V device name> <gain>
Independent Current Source	I	I<name> <+ node> <- node> [[DC] <value>] + [transient specification]
Mutual Inductor	K	K<name> <inductor 1> [<ind. n>*] + <linear coupling or model>
Inductor	L	L<name> <+ node> <- node> [model name] <value> + [IC=<initial value>]
JFET	J	J<name> <drain node> <gate node> <source node> + <model name> [area value]
MOSFET	M	M<name> <drain node> <gate node> <source node> + <bulk/substrate node> [SOI node(s)] + <model name> [common model parameter]*
Bipolar Junction Transistor (BJT)	Q	Q<name> <collector node> <base node> + <emitter node> [substrate node] + <model name> [area value]
Resistor	R	R<name> <+ node> <- node> [model name] <value> + [L=<length>] [W=<width>]
Voltage Controlled Switch	S	S<name> <+ switch node> <- switch node> + <+ controlling node> <- controlling node> + <model name>
Transmission Line	T	T<name> <A port + node> <A port - node> + <B port + node> <B port - node> + <ideal specification>
Independent Voltage Source	V	V<name> <+ node> <- node> [[DC] <value>] + [transient specification]
Subcircuit	X	X<name> [node]* <subcircuit name> + [PARAMS: [<name>=<value>]*]
Current Controlled Switch	W	W<name> <+ switch node> <- switch node> + <controlling V device name> <model name>

Device Type	Designator Letter	Typical Netlist Format
Digital Devices	Y<name>	Y<name> [node]* <model name>
PDE Devices	YPDE	YPDE <name> [node]* <model name>
ROM Devices	YROM	YROM <name> <+ node> <- node> + BASE_FILENAME=<filename> + [MASK_VARS=<true/false>]
MESFET	Z	Z<name> <drain node> <gate node> <source node> + <model name> [area value]

Table 2.9: Analog Device Quick Reference.

## Voltage Nodes

Devices in a netlist are connected between *nodes*, and all device types in **Xyce** require at least two nodes on each instance line. Node names can consist of any printable characters *except* white space (space, tab, newline), parentheses (“(“ or “)”), braces (“{“ or “}”), commas, or the equal sign.

Except for global nodes (below), voltage node names appearing in a subcircuit that are not listed in the subcircuit’s argument list are accessible only to that subcircuit; devices outside the subcircuit cannot connect to local nodes.

### Global nodes

A special syntax is used to designate certain nodes as *global* nodes. Any node whose name starts with the two characters “\$G” is a global node, and such nodes are available to be used in any subcircuit. A typical usage of such global nodes is to define a VDD or VSS signal that all subcircuits need to be able to access, but without having to provide VSS and VDD input nodes to every subcircuit. In this case, a global \$GVDD node would be use for the VDD signal.

The node named 0 is a special global node. Node 0 is always ground, and is accessible to all levels of a hierarchical netlist.

## Capacitor

<b>General Form</b>	C<name> <(+) node> <(-) node> [model name] [value] [device parameters]
<b>Examples</b>	<pre>CM12 2 4 5.288e-13 CLOAD 1 0 4.540pF IC=1.5V CFEEDBACK 2 0 CMOD 1.0pF CAGED 2 3 4.0uF D=0.0233 AGE=86200</pre>
<b>Symbol</b>	
<b>Model Form</b>	.MODEL <model name> C [model parameters]
<b>Parameters and Options</b>	<p>(+) and (-) nodes</p> <p>Polarity definition for a positive voltage across the capacitor. The first node is defined as positive. Therefore, the voltage across the component is the first node voltage minus the second node voltage.</p> <p>[model name]</p> <p>If [model name] is omitted, then &lt;value&gt; is the capacitance in farads. If [model name] is given then the value is determined from the model parameters; see the capacitor value formula below.</p> <p>[value]</p> <p>Positional specification of device parameter C (capacitance). Alternately, this can be specified as a parameter, C=&lt;value&gt;, or in the (optional) model.</p> <p>[device parameters]</p> <p>Parameters listed in Table 2.10 may be provided as space separated &lt;parameter&gt;=&lt;value&gt; specifications as needed. Any number of parameters may be specified.</p>

---

Positive current flows through the capacitor from the (+) node to the (-) node. In general, capacitors should have a positive capacitance value (<value> property). In all cases, the capacitance must not be zero.

**Comments**

However, cases exist when a negative capacitance value may be used. This occurs most often in filter designs that analyze an RLC circuit equivalent to a real circuit. When transforming from the real to the RLC equivalent, the result may contain a negative capacitance value.

In a transient run, negative capacitance values may cause the simulation to fail due to instabilities they cause in the time integration algorithms.

---

## Device Parameters

Table 2.10 gives the available device parameters for the capacitor.

Parameter	Description	Units	Default
AGE	Age of capacitor	hour	0
C	Capacitance	F	1
D	Age degradation coefficient	–	0.0233
IC	Initial voltage drop across device	V	0
L	Semiconductor capacitor width	m	1
TEMP	Device temperature	°C	27
W	Semiconductor capacitor length	m	1e-06

Table 2.10: Capacitor Device Parameters.

## Model Parameters

Table 2.11 gives the available model parameters for the capacitor.

Parameter	Description	Units	Default
CJ	Junction bottom capacitance	F/m <sup>2</sup>	0
CJSW	Junction sidewall capacitance	F/m	0
DEFW	Default device width	m	1e-06

Parameter	Description	Units	Default
NARROW	Narrowing due to side etching	m	0
TC1	Linear temperature coefficient	°C <sup>-1</sup>	0
TC2	Quadratic temperature coefficient	°C <sup>-2</sup>	0
TNOM	Nominal device temperature	°C	27

Table 2.11: Capacitor Model Parameters.

## Capacitor Equations

### Capacitance Value Formula

If [model name] is specified, then the capacitance is given by:

$$C \cdot (1 + \mathbf{TC1} \cdot (T - T_0) + \mathbf{TC2} \cdot (T - T_0)^2)$$

where  $C$  is the base capacitance specified on the device line and is normally positive (though it can be negative, but not zero).  $T_0$  is the nominal temperature (set using **TNOM** option).

### Age-aware Formula

If **AGE** is given, then the capacitance is:

$$C[1 - \mathbf{D} \log(\mathbf{AGE})]$$

### Semiconductor Formula

If [model name] and **L** and **W** are given, then the capacitance is:

$$CJ(\mathbf{L} - \mathbf{NARROW})(\mathbf{W} - \mathbf{NARROW}) + 2 \cdot CJSW(\mathbf{L} - \mathbf{W} + 2 \cdot \mathbf{NARROW})$$

## Inductor

<b>General Form</b>	L<name> <(+) node> <(-) node> [model] <value> + [IC=<initial value>]
<b>Examples</b>	L1 1 5 3.718e-08 LLOAD 3 6 4.540mH IC=2mA Lmodded 3 6 indmod 4.540mH .model indmod L (L=.5 TC1=0.010 TC2=0.0094)
<b>Symbol</b>	
<b>Model Form</b>	.MODEL <model name> L [model parameters]
<b>Parameters and Options</b>	(+) and (-) nodes  Polarity definition for a positive voltage across the inductor. The first node is defined as positive. Therefore, the voltage across the component is the first node voltage minus the second node voltage.  <initial value>  The initial current through the inductor during the bias point calculation.
<b>Comments</b>	In general, inductors should have a positive inductance value (VALUE property). In all cases, the inductance must not be zero. However, cases exist when a negative value may be used. This occurs most often in filter designs that analyze an RLC circuit equivalent to a real circuit. When transforming from the real to the RLC equivalent, the result may contain a negative inductance value.  If a model name is given, the inductance is modified from the value given on the instance line by the parameters in the model card. See "Inductance Value Formula" below. When an inductor is named in the list of coupled inductors in a mutual inductor device line (see page 81) , and that mutual inductor is of the nonlinear-core type, the <value> is interpreted as a number of turns rather than as an inductance in Henries.

## Model Parameters

Table 2.12 gives the available model parameters for the inductor.

Model parameters	Description	Units	Default
L	Inductance Multiplier		1.0
TC1	Linear Temperature Coefficient	°C <sup>-1</sup>	0.0
TC2	Quadratic Temperature Coefficient	°C <sup>-2</sup>	0.0
TNOM	Parameter Measurement Temperature	°C	27.0

Table 2.12: Inductor Model Parameters.

## Inductor Equations

### Inductance Value Formula

If [model name] is specified, then the inductance is given by:

$$L_{base} \cdot L \cdot (1 + TC1 \cdot (T - T_0) + TC2 \cdot (T - T_0)^2)$$

where  $L_{base}$  is the base inductance specified on the device line and is normally positive (though it can be negative, but not zero).  $L$  is the inductance multiplier specified in the model card.  $T_0$  is the nominal temperature (set using **TNOM** option).

## Mutual Inductors

---

**General Form**    K<name> L<inductor name> [L<inductor name>]\* <coupling value>  
                          + [model name]

---

**Examples**

```
KTUNED L3OUT L4IN .8
KTRNSFRM LPRIMARY LSECNDRY 1
KXFRM L1 L2 L3 L4 .98 KPOT_3C8
```

---

**Symbol**

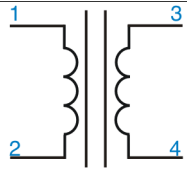

---

**Model Form**    .MODEL <model name> CORE [model parameters]

---

---

L<inductor name> [L<inductor name>\*]

Identifies the inductors to be coupled. The inductors are coupled and in the dot notation the dot is placed on the first node of each inductor. The polarity is determined by the order of the nodes in the L devices and not by the order of the inductors in the K statement.

<coupling value>

The coefficient of mutual coupling, which must be between -1.0 and 1.0.

This coefficient is defined by the equation

$$\text{<coupling value>} = \frac{M_{ij}}{\sqrt{L_i L_j}}$$

where

$L_i$  is the inductance of the  $i$ th named inductor in the K-line

$M_{ij}$  is the mutual inductance between  $L_i$  and  $L_j$

For transformers of normal geometry, use 1.0 as the value. Values less than 1.0 occur in air core transformers when the coils do not completely overlap.

<model name>

If <model name> is present, four things change:

- The mutual coupling inductor becomes a nonlinear, magnetic core device.
  - The inductors become windings, so the number specifying inductance now specifies the number of turns.
  - The list of coupled inductors could be just one inductor.
  - A model statement is required to specify the model parameters.
- 

## **Parameters and Options**

## **Model Parameters**

Table 2.13 gives the available model parameters for mutual inductors.

Parameter	Description	Units	Default
A	Thermal energy parameter	A/m	1000
ALPHA	Domain coupling parameter	–	5e-05
AREA	Mean magnetic cross-sectional area	cm <sup>2</sup>	1e-05
BETAH	Modeling constant	–	0.0001
BETAM	Modeling constant	–	3.125e-05
C	Domain flesing parameter	–	0.2
DELV	Smoothing coefficient for voltage difference over first inductor	V	0.1
GAP	Effective air gap	cm	0
K	Domain anisotropy parameter	A/m	500
KIRR	Domain anisotropy parameter	A/m	500
LEVEL	for pspice compatibility – ignored	–	0
MEQNSCALING	M-equation scaling	–	1e-09
MS	Saturation magnetization	A/m	1e+06
MVARSCALING	M-variable scaling.	–	1e+09
OUTPUTSTATEVARS	Flag to save state variables	–	0
PACK	for pspice compatibility – ignored	–	0
PATH	Total mean magnetic path	cm	0.01
PZEROTOL	Tolerance for nonlinear zero crossing	–	0.1
REQNSCALING	R-equation scaling	–	1e-09
RVARSCALING	R-variable scaling	–	1e+09
TC1	First order temperature coeff.	–	0
TC2	Second order temperature coeff.	–	0
TNOM	Reference temperature	°C	27
VINF	Smoothing coefficient for voltage difference over first inductor	V	1

Table 2.13: Nonlinear Mutual Inductor Device Model Parameters.

### Special Notes

As of Xyce Release 4.1, the coupling coefficient of the linear mutual inductor (i.e. a mutual inductor without a core model) is permitted to be a time- or solution variable-dependent expression. This is intended to allow simulation of electromechanical devices in which there might be moving coils that interact with fixed coils.

## Resistor

<b>General Form</b>	R<name> <(+) node> <(-) node> [model name] [value] [device parameters]
<b>Examples</b>	<pre>R1 1 2 2K TEMP=27 RLOAD 3 6 RTCMOD 4.540 TEMP=85 .MODEL RTCMOD R (TC1=.01 TC2=-.001) RSEMICOND 2 0 RMOD L=1000u W=1u .MODEL RMOD R (RSH=1)</pre>
<b>Symbol</b>	
<b>Model Form</b>	.MODEL <model name> R [model parameters]
	(+) and (-) nodes
	<p>Polarity definition for a positive voltage across the resistor. The first node is defined as positive. Therefore, the voltage across the component is the first node voltage minus the second node voltage. Positive current flows from the positive node (first node) to the negative node (second node).</p>
	[model name]
	<p>If [model name] is omitted, then [value] is the resistance in Ohms. If [model name] is given then the resistance is determined from the model parameters; see the resistance value formula below.</p>
<b>Parameters and Options</b>	[value]
	<p>Positional specification of device parameter R (resistance). Alternately, this can be specified as a parameter, R=&lt;value&gt;, or in the (optional) model.</p>
	[device parameters]
	<p>Parameters listed in Table 2.14 may be provided as space separated &lt;parameter&gt;=&lt;value&gt; specifications as needed. Any number of parameters may be specified.</p>
<b>Comments</b>	Resistors must have a positive (nonzero) resistance value (R)

## Device Parameters

Table 2.14 gives the available device parameters for the resistor.

Parameter	Description	Units	Default
L	Length	m	0
R	Resistance	$\Omega$	1000
TEMP	Temperature	$^{\circ}\text{C}$	27
W	Width	m	1e-05

Table 2.14: Resistor Device Parameters.

## Model Parameters

Table 2.15 gives the available model parameters for the resistor.

Parameter	Description	Units	Default
DEFW	Default Instance Width	m	1e-05
NARROW	Narrowing due to side etching	m	0
RSH	Sheet Resistance	$\Omega$	0
TC1	Linear Temperature Coefficient	$^{\circ}\text{C}^{-1}$	0
TC2	Quadratic Temperature Coefficient	$^{\circ}\text{C}^{-2}$	0
TNOM	Parameter Measurement Temperature	$^{\circ}\text{C}$	27

Table 2.15: Resistor Model Parameters.

## Resistor Equations

### Resistance Value Formula

If [model name] is included, then the resistance is:

$$R \cdot (1 + \text{TC1} \cdot (T - T_0) + \text{TC2} \cdot (T - T_0)^2)$$

If L and W are given, the resistance is:

$$RSH \frac{[L - \text{NARROW}]}{[W - \text{NARROW}]}$$

## Thermal (level=2) Resistor

Xyce supports a thermal resistor model, which is associated with level=2.

### Thermal Resistor Instance Parameters

Table 2.16 gives the available instance parameters for the thermal (level=2) resistor.

Parameter	Description	Units	Default
A	Area of conductor	m <sup>2</sup>	0
DENSITY	Resistor material density (unused)	kg/m <sup>3</sup>	0
HEATCAPACITY	Resistor material volumetric heat capacity	J/(m <sup>3</sup> °K)	0
L	Length of conductor	m	0
OUTPUTINTVARS	Debug Output switch	–	False
R	Resistance	Ω	1000
RESISTIVITY	Resistor material resistivity	Ω-m	0
TEMP	Temperature	°C	27
THERMAL_A	Area of material thermally coupled to conductor	m <sup>2</sup>	0
THERMAL_HEATCAPACITY	Volumetric heat capacity of material thermally coupled to conductor	J/(m <sup>3</sup> °K)	0
THERMAL_L	Length of material thermally coupled to conductor	m	0
W	Width of conductor	m	1e-05

Table 2.16: Resistor Device Instance Parameters.

### Thermal Resistor Model Parameters

Table 2.17 gives the available model parameters for the thermal (level=2) resistor.

Parameter	Description	Units	Default
DEFW	Default Instance Width	m	1e-05
DENSITY	Resistor material density (unused)	kg/m <sup>3</sup>	0
HEATCAPACITY	Resistor material volumetric heat capacity	J/(m <sup>3</sup> °K)	0
NARROW	Narrowing due to side etching	m	0

Parameter	Description	Units	Default
RESISTIVITY	Resistor material resistivity	$\Omega\text{-m}$	0
RSH	Sheet Resistance	$\Omega$	0
TC1	Linear Temperature Coefficient	$^{\circ}\text{C}^{-1}$	0
TC2	Quadratic Temperature Coefficient	$^{\circ}\text{C}^{-2}$	0
THERMAL_HEATCAPACITY	Volumetric heat capacity of material thermally coupled to conductor	$J/(\text{m}^3\text{K})$	0
TNOM	Parameter Measurement Temperature	$^{\circ}\text{C}$	27

Table 2.17: Resistor Device Model Parameters.

## Diode

<b>General Form</b>	D<name> <(+) node> <(-) node> <model name> [area value]
<b>Examples</b>	DCLAMP 1 0 DMOD D2 15 17 SWITCH 1.5
<b>Symbol</b>	
<b>Model Form</b>	.MODEL <model name> D [model parameters] <(+) node> The anode. <(-) node> The cathode. [area value] Scales IS, ISR, IKF, RS, CJO, and IBV, and has a default value of 1. IBV and BV are both specified as positive values.
<b>Comments</b>	The diode is modeled as an ohmic resistance ( $R_S/area$ ) in series with an intrinsic diode. Positive current is current flowing from the anode through the diode to the cathode.

### Diode Operating Temperature

Model parameters can be assigned unique measurement temperatures using the **TNOM** model parameter.

### Diode level selection

Two distinct implementations of the diode are available. These are selected by using the **LEVEL** model parameter. The default implementation is based on SPICE 3F5, and may be explicitly specified using **LEVEL=1** in the model parameters, but is also selected if no **LEVEL** parameter is specified. The PSpice implementation [2] is obtained by specifying **LEVEL=2**.

The **Xyce** **LEVEL=1** and **LEVEL=2** diodes have a parameter, **IRF**, that allows the user to adjust the reverse current from the basic SPICE implementation. The usual SPICE treatment defines the linear portion of the reverse current in terms of **IS** which is defined by the

forward current characteristics. Data shows that often the reverse current is quite far off when determined in this manner. The parameter **IRF** is a multiplier that can be applied to adjust the linear portion of the reverse current.

## Device Parameters

Table 2.18 gives the available device parameters for the diode.

Parameter	Description	Units	Default
AREA	Area scaling value (scales IS, ISR, IKF, RS, CJO, and IBV)	–	1
IC	Initial voltage drop across device	V	0
LAMBERTW	Option to solve diode equations with the Lambert-W function	logical (T/F)	0
OFF	Initial voltage drop across device set to zero	logical (T/F)	0
TEMP	Device temperature	°C	27

Table 2.18: Diode Device Parameters.

## Model Parameters

Table 2.19 gives the available model parameters for the LEVEL=1 and LEVEL=2 diodes.

Parameter	Description	Units	Default
AF	Flicker noise exponent	–	1
BV	Reverse breakdown "knee" voltage	V	1e+99
CJO	Zero-bias p-n depletion capacitance	F	0
EG	Bandgap voltage (barrier height)	eV	1.11
FC	Forward-bias depletion capacitance coefficient	–	0.5
IBV	Reverse breakdown "knee" current	A	0.001
IBVL	Low-level reverse breakdown "knee" current (level 2)	A	0
IKF	High-injection "knee" current (level 2)	A	0
IRF	Reverse current fitting factor	–	1
IS	Saturation current	A	1e-14
ISR	Recombination current parameter (level 2)	A	0

Parameter	Description	Units	Default
KF	Flicker noise coefficient	–	0
M	Grading parameter for p-n junction	–	0.5
N	Emission coefficient	–	1
NBV	Reverse breakdown ideality factor (level 2)	–	1
NBVL	Low-level reverse breakdown ideality factor (level 2)	–	1
NR	Emission coefficient for ISR (level 2)	–	2
RS	Parasitic resistance	$\Omega$	0
TBV1	BV temperature coefficient (linear) (level 2)	$^{\circ}\text{C}^{-1}$	0
TBV2	BV temperature coefficient (quadratic) (level 2)	$^{\circ}\text{C}^{-2}$	0
TIKF	IKF temperature coefficient (linear) (level 2)	$^{\circ}\text{C}^{-1}$	0
TNOM	Nominal device temperature	$^{\circ}\text{C}$	27
TRS1	RS temperature coefficient (linear) (level 2)	$^{\circ}\text{C}^{-1}$	0
TRS2	RS temperature coefficient (quadratic) (level 2)	$^{\circ}\text{C}^{-2}$	0
TT	Transit time	s	0
VJ	Potential for p-n junction	V	1
XTI	IS temperature exponent	–	3

Table 2.19: Diode Model Parameters.

## Diode Equations

The equations in this section use the following variables:

$V_{di}$  = voltage across the intrinsic diode only

$V_{th}$  =  $k \cdot T/q$  (thermal voltage)

$k$  = Boltzmann's constant

$q$  = electron charge

$T$  = analysis temperature (Kelvin)

$T_0$  = nominal temperature (set using TNOM option)

$\omega$  = Frequency (Hz)

Other variables are listed above in the diode model parameters.

Level=1

The level 1 diode is based on the Spice3f5 level 1 model.

DC Current (Level=1)

The intrinsic diode current consists of forward and reverse bias regions where

$$I_D = \begin{cases} \mathbf{IS} \cdot \left[ \exp\left(\frac{V_{di}}{\mathbf{NV}_{th}}\right) - 1 \right], & V_{di} > -3.0 \cdot \mathbf{NV}_{th} \\ -\mathbf{IS} \cdot \mathbf{IRF} \cdot \left[ 1.0 + \left(\frac{3.0 \cdot \mathbf{NV}_{th}}{V_{di} \cdot e}\right)^3 \right], & V_{di} < -3.0 \cdot \mathbf{NV}_{th} \end{cases}$$

**IRF** is a **Xyce**-specific parameter that can be used to scale the reverse-biased current to match measured data. It defaults to 1.0, which reduces the model to strict SPICE3F5 compatibility.

When **BV** and an optional parameter **IBV** are explicitly given in the model statement, an exponential model is used to model reverse breakdown (with a “knee” current of **IBV** at a “knee-on” voltage of **BV**). The equation for  $I_D$  implemented by **Xyce** is given by

$$I_D = -\mathbf{IBV}_{\text{eff}} \cdot \exp\left(-\frac{\mathbf{BV}_{\text{eff}} + V_{di}}{\mathbf{NV}_{th}}\right), \quad V_{di} \leq \mathbf{BV}_{\text{eff}},$$

where  $\mathbf{BV}_{\text{eff}}$  and  $\mathbf{IBV}_{\text{eff}}$  are chosen to satisfy the following constraints:

1. Continuity of  $I_D$  between reverse bias and reverse breakdown regions (i.e., continuity of  $I_D$  at  $V_{di} = -\mathbf{BV}_{\text{eff}}$ ):

$$\mathbf{IBV}_{\text{eff}} = \mathbf{IRF} \cdot \mathbf{IS} \left( 1 - \left(\frac{3.0 \cdot \mathbf{NV}_{th}}{e \cdot \mathbf{BV}_{\text{eff}}}\right)^3 \right)$$

2. “Knee-on” voltage/current matching:

$$\mathbf{IBV}_{\text{eff}} \cdot \exp\left(-\frac{\mathbf{BV}_{\text{eff}} - \mathbf{BV}}{\mathbf{NV}_{th}}\right) = \mathbf{IBV}$$

Substituting the first expression into the second yields a single constraint on  $\mathbf{BV}_{\text{eff}}$  which cannot be solved for directly. By performing some basic algebraic manipulation and rearranging terms, the problem of finding  $\mathbf{BV}_{\text{eff}}$  which satisfies the above two constraints can be cast as finding the (unique) solution of the equation

$$\mathbf{BV}_{\text{eff}} = f(\mathbf{BV}_{\text{eff}}), \tag{2.1}$$

where  $f(\cdot)$  is the function that is obtained by solving for the  $BV_{\text{eff}}$  term which appears in the exponential in terms of  $BV_{\text{eff}}$  and the other parameters. **Xyce** solves Eqn. 2.1 by performing the so-called *Picard Iteration* procedure [5], i.e. by producing successive estimates of  $BV_{\text{eff}}$  (which we will denote as  $BV_{\text{eff}}^k$ ) according to

$$BV_{\text{eff}}^{k+1} = f(BV_{\text{eff}}^k)$$

starting with an initial guess of  $BV_{\text{eff}}^0 = BV$ . The current iteration procedure implemented in **Xyce** can be shown to guarantee at least six significant digits of accuracy between the numerical estimate of  $BV_{\text{eff}}$  and the true value.

In addition to the above, **Xyce** also requires that  $BV_{\text{eff}}$  lie in the range  $BV \geq BV_{\text{eff}} \geq 3.0NV_{th}$ . In terms of  $IBV$ , this is equivalent to enforcing the following two constraints:

$$IRF \cdot IS \left( 1 - \left( \frac{3.0 \cdot NV_{th}}{e \cdot BV} \right)^3 \right) \leq IBV \quad (2.2)$$

$$IRF \cdot IS (1 - e^{-3}) \exp \left( \frac{-3.0 \cdot NV_{th} + BV}{NV_{th}} \right) \geq IBV \quad (2.3)$$

**Xyce** first checks the value of  $IBV$  to ensure that the above two constraints are satisfied. If Eqn. 2.2 is violated, **Xyce** sets  $IBV_{\text{eff}}$  to be equal to the left-hand side of Eqn. 2.2 and, correspondingly, sets  $BV_{\text{eff}}$  to  $-3.0 \cdot NV_{th}$ . If Eqn. 2.3 is violated, **Xyce** sets  $IBV_{\text{eff}}$  to be equal to the left-hand side of Eqn. 2.3 and, correspondingly, sets  $BV_{\text{eff}}$  to  $BV$ .

### Capacitance (Level=1)

The p-n diode capacitance consists of a depletion layer capacitance  $C_d$  and a diffusion capacitance  $C_{dif}$ . The first is given by

$$C_d = \begin{cases} CJ \cdot AREA \left( 1 - \frac{V_{di}}{VJ} \right)^{-M}, & V_{di} \leq FC \cdot VJ \\ \frac{CJ \cdot AREA}{F2} \left( F3 + M \frac{V_{di}}{VJ} \right), & V_{di} > FC \cdot VJ \end{cases}$$

The diffusion capacitance (sometimes referred to as the transit time capacitance) is

$$C_{dif} = TT G_d = TT \frac{dI_D}{dV_{di}}$$

where  $G_d$  is the junction conductance.

### Temperature Effects (Level=1)

The diode model contains explicit temperature dependencies in the ideal diode current, the generation/recombination current and the breakdown current. Further temperature

dependencies are present in the diode model via the saturation current  $I_S$ , the depletion layer junction capacitance  $CJ$ , the junction potential  $V_J$ .

$$\begin{aligned}
 V_t(T) &= \frac{kT}{q} \\
 V_{tnom}(T) &= \frac{k\mathbf{TNOM}}{q} \\
 E_g(T) &= E_{g0} - \frac{\alpha T^2}{\beta + T} \\
 E_{gNOM}(T) &= E_{g0} - \frac{\alpha \mathbf{TNOM}^2}{\mathbf{TNOM} + \beta} \\
 arg1(T) &= -\frac{E_g(T)}{2kT} + \frac{E_{g300}}{2kT_0} \\
 arg2(T) &= -\frac{E_{gNOM}(T)}{2k\mathbf{TNOM}} + \frac{E_{g300}}{2kT_0} \\
 pbfact1(T) &= -2.0 \cdot V_t(T) \left( 1.5 \cdot \ln \left( \frac{T}{T_0} \right) + q \cdot arg1(T) \right) \\
 pbfact2(T) &= -2.0 \cdot V_{tnom}(T) \left( 1.5 \cdot \ln \left( \frac{\mathbf{TNOM}}{T_0} \right) + q \cdot arg2(T) \right) \\
 pbo(T) &= (\mathbf{VJ} - pbfact2(T)) \frac{T_0}{\mathbf{TNOM}} \\
 V_J(T) &= pbfact1(T) + \frac{T}{T_0} pbo(T) \\
 gma_{old}(T) &= \frac{\mathbf{VJ} - pbo(T)}{pbo(T)} \\
 gma_{new}(T) &= \frac{V_J(T) - pbo(T)}{pbo(T)} \\
 CJ(T) &= \mathbf{CJ0} \frac{1.0 + \mathbf{M} (4.0 \times 10^{-4} (T - T_0) - gma_{new}(T))}{1.0 + \mathbf{M} (4.0 \times 10^{-4} (\mathbf{TNOM} - T_0) - gma_{old}(T))} \\
 I_S(T) &= \mathbf{IS} \cdot \exp \left( \left( \frac{T}{\mathbf{TNOM}} - 1.0 \right) \cdot \frac{\mathbf{EG}}{\mathbf{NV}_t(T)} + \frac{\mathbf{XTI}}{\mathbf{N}} \cdot \ln \left( \frac{T}{\mathbf{TNOM}} \right) \right)
 \end{aligned}$$

where, for silicon,  $\alpha = 7.02 \times 10^{-4} \text{ eV/K}$ ,  $\beta = 1108 \text{ }^\circ\text{K}$  and  $E_{g0} = 1.16 \text{ eV}$ .

For a more thorough description of p-n junction physics, see [9]. For a thorough description of the U.C. Berkeley SPICE models see Reference [11].

## Independent Current Source

<b>General Form</b>	<code>I&lt;name&gt; &lt;(+) node&gt; &lt;(-) node&gt; + [ [DC] &lt;value&gt; ]</code> + [transient specification]
<b>Examples</b>	<code>ISLOW 1 22 SIN(0.5 1.0ma 1KHz 1ms)</code> <code>IPULSE 1 3 PULSE(-1 1 2ns 2ns 2ns 50ns 100ns)</code>
<b>Symbol</b>	
<b>Description</b>	Positive current flows from the positive node through the source to the negative node. Both constant DC values and time-dependent values for the source can be specified. One or both of the DC and transient values may be specified. [transient specification]
<b>Parameters and Options</b>	There are five predefined time-varying functions for sources: <ul style="list-style-type: none"> <li>■ <code>PULSE(&lt;parameters&gt;)</code> - pulse waveform</li> <li>■ <code>SIN(&lt;parameters&gt;)</code> - sinusoidal waveform</li> <li>■ <code>EXP(&lt;parameters&gt;)</code> - exponential waveform</li> <li>■ <code>PWL(&lt;parameters&gt;)</code> - piecewise linear waveform</li> <li>■ <code>SFFM(&lt;parameters&gt;)</code> - frequency-modulated waveform</li> </ul>

### Transient Specifications

This section outlines the available transient specifications.  $\Delta t$  and  $T_F$  are the time step size and simulation end-time, respectively.

#### Pulse

`PULSE(I1 I2 TD TR TF PW PER)`

Parameter	Default	Unit
I1 (Initial Value)	N/A	amp
I2 (Pulse Value)	N/A	amp
TD (Delay Time)	0.0	s
TR (Rise Time)	$\Delta t$	s
TF (Fall Time)	$\Delta t$	s
PW (Pulse Width)	$T_F$	s
PER (Period)	$T_F$	s

Sine

SIN(I0 IA FREQ TD THETA)

Parameter	Default	Unit
I0 (Offset)	N/A	amp
IA (Amplitude)	N/A	amp
FREQ (Frequency)	0.0	s
TD (Delay)	$\Delta t$	s
THETA (Attenuation Factor)	$\Delta t$	s

The waveform is shaped according to the following equations:

$$I = \begin{cases} I_0, & 0 < t < T_D \\ I_0 + I_A \sin[2\pi \cdot \mathbf{FREQ} \cdot (t - T_D)] \exp[-(t - T_D) \cdot \mathbf{THETA}], & T_D < t < T_F \end{cases}$$

Exponent

EXP(I1 I2 TD1 TAU1 TD2 TAU2)

Parameter	Default	Unit
I1 (Initial Phase)	N/A	amp
IA (Amplitude)	N/A	amp
TD1 (Rise Delay Time)	0.0	s
TAU1 (Rise Time Constant)	$\Delta t$	s
TD2 (Delay Fall Time)	TD1 + $\Delta t$	s
TAU2 (Fall Time Constant)	$\Delta t$	s

The waveform is shaped according to the following equations:

$$I = \begin{cases} I_1, & 0 < t < TD1 \\ I_1 + (I_2 - I_1)\{1 - \exp[-(t - TD1)/TAU1]\}, & TD1 < t < TD2 \\ I_1 + (I_2 - I_1)\{1 - \exp[-(t - TD1)/TAU1]\} \\ \quad + (I_1 - I_2)\{1 - \exp[-(t - TD2)/TAU2]\}, & TD2 < t < T_2 \end{cases}$$

### Piecewise Linear

PWL <t0> <i0> [<tn> <in>]\*

PWL FILE "<name>"

Parameter	Default	Unit
<tn> (Time at Corner)	s	none
<in> (Current at Corner)	amp	none
<n> (Number of Repetitions)	positive integer, 0, or -1	none

When the FILE option is given, **Xyce** will read the corner points from the file specified in the <name> field. This file should be a plain ASCII text file with time/current pairs. There should be one pair per line, and the time and current values should be separated by whitespace or commas.

### Frequency Modulated

SFFM (<ioff> <iAMPL> <fc> <mod> <fm>)

Parameter	Default	Unit
<i <sub>off</sub> > (Offset Current)	amp	none
<i <sub>amp1</sub> > (Peak Current Amplitude)	amp	none
<f <sub>c</sub> > (Carrier Frequency)	hertz	1/TSTOP
<mod> (Modulation Index)		0
<f <sub>m</sub> > (Modulation Frequency)	hertz	1/TSTOP

The waveform is shaped according to the following equations:

$$V = \mathbf{i\text{off}} + \mathbf{i\text{amp1}} \cdot \sin(2\pi \cdot \mathbf{f\text{c}} \cdot \mathbf{TIME} + \mathbf{mod} \cdot \sin(2\pi \cdot \mathbf{f\text{m}} \cdot \mathbf{TIME}))$$

where **TIME** is the current simulation time.

## Independent Voltage Source

The syntax of this device is exactly the same as for an Independent Current Source. For an Independent Voltage Source, substitute an I for the V on the instance line. The V device generates a voltage, whereas the I device generates a current. For details about the Independent Current Source, see section 2.2.

<b>General Form</b>	V<name> <(+) node> <(-) node> + [ [DC] <value> ] + [transient specification]
<b>Examples</b>	VSLOW 1 22 SIN(0.5 1.0ma 1kHz 1ms) VPULSE 1 3 PULSE(-1 1 2ns 2ns 2ns 50ns 100ns)
<b>Symbol</b>	
<b>Description</b>	Positive current flows from the positive node through the source to the negative node. Both constant DC values and time-dependent values for the source can be specified. One or both of the DC and transient values may be specified. [transient specification]
<b>Parameters and Options</b>	There are five predefined time-varying functions for sources: <ul style="list-style-type: none"> <li>■ PULSE(&lt;parameters&gt;) - pulse waveform</li> <li>■ SIN(&lt;parameters&gt;) - sinusoidal waveform</li> <li>■ EXP(&lt;parameters&gt;) - exponential waveform</li> <li>■ PWL(&lt;parameters&gt;) - piecewise linear waveform</li> <li>■ SFFM(&lt;parameters&gt;) - frequency-modulated waveform</li> </ul>

## Voltage Controlled Voltage Source

<b>General Form</b>	<pre>E&lt;name&gt; &lt;(+) node&gt; &lt;(-) node&gt; &lt;(+) controlling node&gt; + &lt;(-) controlling node&gt; &lt;gain&gt; E&lt;name&gt; &lt;(+) &lt;node&gt; &lt;(-) node&gt; VALUE = { &lt;expression&gt; } E&lt;name&gt; &lt;(+) &lt;node&gt; &lt;(-) node&gt; TABLE { &lt;expression&gt; } = + &lt; &lt;input value&gt;,&lt;output value&gt; &gt;*</pre>
<b>Examples</b>	<pre>EBUFFER 1 2 10 11 5.0 ESQROOT 5 0 VALUE = {5V*SQRT(V(3,2))} ET2 2 0 TABLE {V(ANODE,CATHODE)} = (0,0) (30,1)</pre>
<b>Symbol</b>	
<b>Description</b>	<p>In the first form, a specified voltage drop elsewhere in the circuit controls the voltage-source output. The second and third forms using the VALUE and TABLE keywords, respectively, are used in analog behavioral modeling. These two forms are automatically converted within <b>Xyce</b> to its principal ABM device, the B nonlinear dependent source device. See the <b>Xyce</b> User's Guide for more information on analog behavioral modeling.</p>
<b>Parameters and Options</b>	<p>(+) and (-) nodes</p> <p>Output nodes. Positive current flows from the (+) node through the source to the (-) node.</p> <p>&lt;(+) controlling node&gt; and &lt;(-) controlling node&gt;</p> <p>Node pairs that define a set of controlling voltages. A given node may appear multiple times and the output and controlling nodes may be the same.</p>

## Current Controlled Current Source

<b>General Form</b>	<pre>F&lt;name&gt; &lt;(+) node&gt; &lt;(-) node&gt; + &lt;controlling V device name&gt; &lt;gain&gt; F&lt;name&gt; &lt;(+) node&gt; &lt;(-) node&gt; POLY(&lt;value&gt;) + &lt;controlling V device name&gt;* + &lt;polynomial coefficient value&gt; &gt;*</pre>
<b>Examples</b>	<pre>FSENSE 1 2 VSENSE 10.0 FAMP 13 0 POLY(1) VIN 0 500 FNONLIN 100 101 POLY(2) VCNTRL1 VCINTRL2 0.0 13.6 0.2 0.005</pre>
<b>Symbol</b>	
<b>Description</b>	<p>In the first form, a specified current elsewhere in the circuit controls the current-source output. The second form using the POLY keyword is used in analog behavioral modeling. This form is automatically converted within <b>Xyce</b> to its principal ABM device, the B nonlinear dependent source device. See the <b>Xyce</b> User's Guide for more information on analog behavioral modeling.</p>
<b>Parameters and Options</b>	<p>(+) and (-) nodes Output nodes. Positive current flows from the (+) node through the source to the (-) node.</p> <p>&lt;controlling V device name&gt; The controlling voltage source which must be an independent voltage source (V device).</p>

## Current Controlled Voltage Source

The syntax of this device is exactly the same as for a Current Controlled Current Source. For a Current-Controlled Voltage Source just substitute an H for the F. The H device generates a voltage, whereas the F device generates a current.

---

	H<name> <(+) node> <(-) node> + <controlling V device name> <gain>
<b>General Form</b>	H<name> <(+) node> <(-) node> POLY(<value>) + <controlling V device name>* + < <polynomial coefficient value> >*
<b>Examples</b>	HSENSE 1 2 VSENSE 10.0 HAMP 13 0 POLY(1) VIN 0 500 HNONLIN 100 101 POLY(2) VCNTRL1 VCINTRL2 0.0 13.6 0.2 0.005
<b>Symbol</b>	

---

## Voltage Controlled Current Source

<b>General Form</b>	<pre>G&lt;name&gt; &lt;(+) node&gt; &lt;(-) node&gt; &lt;(+) controlling node&gt; + &lt;(-) controlling node&gt; &lt;transconductance&gt; G&lt;name&gt; &lt;(+) &lt;node&gt; &lt;(-) node&gt; VALUE = { &lt;expression&gt; } G&lt;name&gt; &lt;(+) &lt;node&gt; &lt;(-) node&gt; TABLE { &lt;expression&gt; } = + &lt; &lt;input value&gt;, &lt;output value&gt; &gt;*</pre>
<b>Examples</b>	<pre>GBUFFER 1 2 10 11 5.0 GPSK 11 6 VALUE = {5MA*SIN(6.28*10kHz*TIME+V(3))} GA2 2 0 TABLE {V(5)} = (0,0) (1,5) (10,5) (11,0)</pre>
<b>Symbol</b>	
<b>Description</b>	<p>In the first form, a specified voltage drop elsewhere in the circuit controls the current-source output. The second and third forms using the VALUE and TABLE keywords, respectively, are used in analog behavioral modeling. These two forms are automatically converted within <b>Xyce</b> to its principal ABM device, the B nonlinear dependent source device. See the <b>Xyce</b> User's Guide for more information on analog behavioral modeling.</p>
<b>Parameters and Options</b>	<p>(+) and (-) nodes</p> <p>Output nodes. Positive current flows from the (+) node through the source to the (-) node.</p> <p>&lt;(+) controlling node&gt; and &lt;(-) controlling node&gt;</p> <p>Node pairs that define a set of controlling voltages. A given node may appear multiple times and the output and controlling nodes may be the same.</p>

## Nonlinear Dependent Source

<b>General Form</b>	B<name> <(+) node> <(-) node> V={ABM expression} B<name> <(+) node> <(-) node> I={ABM expression}
<b>Examples</b>	B1 2 0 V={sqrt(V(1))} B2 4 0 V={V(1)*TIME} B3 4 2 I={I(V1) + V(4,2)/100} B4 5 0 V={Table {V(5)}=(0,0) (1.0,2.0) (2.0,3.0) (3.0,10.0)}
<b>Description</b>	The nonlinear dependent source device, also known as the B-source device, is used in analog behavioral modeling (ABM). The (+) and (-) nodes are the output nodes. Positive current flows from the (+) node through the source to the (-) node.
<b>Comments</b>	See the “Analog Behavioral Modeling” chapter of the <b>Xyce</b> User’s Guide for more information on the Bsource device and ABM expressions, and the “Parameters and Expressions” section of the User’s Guide for more information on expressions in general. <b>Note: the braces surrounding all expressions are required.</b>

## Bipolar Junction Transistor (BJT)

<b>General Form</b>	Q<name> < collector node> <base node> <emitter node> + [substrate node] <model name> [area value]
<b>Examples</b>	Q2 10 2 9 PNP1 Q12 14 2 0 1 NPN2 2.0 Q6 VC 4 11 [SUB] LAXPNP
<b>Symbols</b>	
<b>Model Form</b>	.MODEL <model name> NPN [model parameters] .MODEL <model name> PNP [model parameters] .MODEL <model name> VBIC [model parameters]
<b>Parameters and Options</b>	<p>[substrate node]</p> <p>Optional and defaults to ground. Since <b>Xyce</b> permits alphanumeric node names and because there is no easy way to make a distinction between these and the model names, the name (not a number) used for the substrate node must be enclosed in square brackets [ ]. Otherwise, nodes would be interpreted as model names. See the fourth example above.</p> <p>[area value]</p> <p>The relative device area with a default value of 1.</p>

**Comments**

The BJT is modeled as an intrinsic transistor using ohmic resistances in series with the collector ( $R_C/\text{area}$ ), with the base (value varies with current, see BJT equations) and with the emitter ( $R_E/\text{area}$ ). For model parameters with optional names, such as VAF and VA (the optional name is in parentheses), either may be used. For model types NPN and PNP, the isolation junction capacitance is connected between the intrinsic-collector and substrate nodes. This is the same as in SPICE and works well for vertical IC transistor structures.

The third model card in the **Model Form** section above is a deprecated form that was required for Release 5.1 of **Xyce**, and selected the NPN VBIC model. The VBIC model in Release 5.2 fully supports both PNP and NPN transistors, and so NPN and PNP model cards are now the preferred way to specify VBIC models. The VBIC model card will be dropped in a future release of **Xyce**.

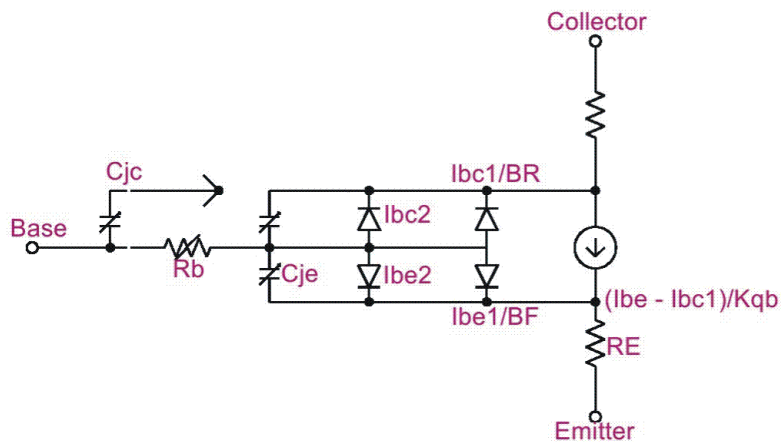

**Figure 2.1.** BJT model schematic. Adapted from reference [2].

### BJT Level selection

**Xyce** supports the level 1 BJT model, which is based on the documented standard SPICE 3F5 BJT model, but was coded independently at Sandia. It is mostly based on the classic Gummel-Poon BJT model [6].

Beginning with **Xyce** Release 5.1, a version of the VBIC model is provided as BJT level

10. This is the 3-terminal, electrothermal, constant phase model of VBIC version 1.2 [7]. The **Xyce** implementation of this model is provided for experimental use and should be considered a beta release. As of version 5.1.2 of **Xyce**, this model contains voltage limiting convergence enhancements, and so is much more stable than in previous releases.

As of release 5.2 of **Xyce**, the VBIC model supports both PNP and NPN transistors, and may therefore be used with model cards of type PNP and NPN. In prior releases, it was necessary to use the model type VBIC to emphasize the absence of PNP support. The VBIC model card required by the prior release is still supported, but is now deprecated in favor of the normal BJT model types.

### BJT Operating Temperature

Model parameters may be assigned unique measurement temperatures using the TNOM model parameter. See BJT model parameters for more information.

### Level=1 Model Parameters

Table 2.20 gives the available model parameters for the level 1 BJT.

Model parameters	Description	Units	Default
BF	Ideal Maximum Forward Beta		100.0
BR	Ideal Maximum Reverse Beta		1.0
CJC	Base-collector Zero-bias p-n Capacitance	farad	0.0
CJE	Base-emitter Zero-bias p-n Capacitance	farad	0.0
CJS	Substrate Zero-bias p-n Capacitance	farad	0.0
EG	Bandgap Voltage (Barrier Height)	eV	1.11
FC	Forward-bias Depletion Capacitor Coefficient		0.5
IKF	Corner for Forward-beta High-current Roll-off	amp	1E99
IKR	Corner for Reverse-beta High-current Roll-off	amp	1E99
IRB	Current at which Rb Falls off by half	amp	0.0
IS	Transport Saturation Current	amp	1E-16
ISC	Base-collector Leakage Saturation Current	amp	0.0
ISE	Base-emitter Leakage Saturation Current	amp	0.0

Model parameters	Description	Units	Default
ITF	Transit Time Dependency on Ic	amp	0.0
KF	Flicker Noise Coefficient		0.0
MJC	Base-collector p-n Grading Factor		0.33
MJE	Base-emitter p-n Grading Factor		0.33
MJS	Substrate p-n Grading Factor		0.0
NC	Base-collector Leakage Emission Coefficient		2.0
NE	Base-emitter Leakage Emission Coefficient		1.5
NF	Forward Current Emission Coefficient		1.0
NK	High Current Rolloff Coefficient		0.5
NR	Reverse Current Emission Coefficient		1.0
PTF	Excess Phase @ $1/(2\pi \cdot TF)$ Hz	degree	0.0
RB	Zero-bias (Maximum) Base Resistance	ohm	0.0
RBM	Minimum Base Resistance	ohm	0.0
RC	Collector Ohmic Resistance	ohm	0.0
RE	Emitter Ohmic Resistance	ohm	0.0
TEMPMODEL	Specification to type of parameter interpolation over temperature	string	
TF	Ideal Forward Transit Time	sec	0.0
TR	Ideal Reverse Transit Time	sec	0.0
TNOM	Parameter Measurement Temperature	°C	27.0
VAF	Forward Early Voltage	volt	1E99
VAR	Reverse Early Voltage	volt	1E99
VJC	Base-collector Built-in Potential	volt	0.75
VJE	Base-emitter Built-in Potential	volt	0.75
VJS	Substrate Built-in Potential	volt	0.75
VTF	Transit Time Dependency on $V_{bc}$	volt	1E99
XCJC	Fraction of <b>CJC</b> Connected Internally to <b>RB</b>		1.0
XTB	Forward and Reverse Beta Temperature Coefficient		0.0
XTF	Transit Time Bias Dependence Coefficient		0.0

Model parameters	Description	Units	Default
------------------	-------------	-------	---------

Table 2.20: BJT Model Parameters.

### Level=10 model parameters

Table 2.21 gives the available model parameters for the level 10 BJT.

¿

Parameter	Description	Units	Default
AFN	Base-Emitter Flicker Noise coefficient (unused)	–	1
AJC	Base-Collector capacitor smoothing factor	–	-0.5
AJE	Base-Emitter capacitor smoothing factor	–	-0.5
AJS	Substrate-collector capacitor smoothing factor (unused)	–	-0.5
ART		–	0.1
AVC1	B-C weak avalanche parameter	V <sup>-1</sup>	0
AVC2	B-C weak avalanche parameter	V <sup>-1</sup>	0
BFN	B-E flicker noise dependence (unused)	–	1
CBCD	Extrinsic B-C overlap capacitance	F	0
CBE0	Extrinsic B-E overlap capacitance	F	0
CCS0	(unused)	–	0
CJC	B-C zero-bias capacitance	F	0
CJCP	S-C zero-bias capacitance	F	0
CJE	B-E zero-bias capacitance	F	0
CJEP	S-E zero-bias capacitance	F	0
CTH	Thermal capacitance	F	0
DEAR	Activation energy for ISRR	–	0
DTEMP	Device temperature (use 0.0 for ambient)	–	0
EA	Activation energy for IS	eV	1.12
EAIC	Activation energy for IBCI	eV	1.12
EAIE	Activation energy for IBEL	eV	1.12
EAIS	Activation energy for IBCIP	eV	1.12
EANC	Activation energy for IBCN	eV	1.12

Parameter	Description	Units	Default
EANE	Activation energy for IBEN	eV	1.12
EANS	Activation energy for IBCNP	eV	1.12
EAP	Activation energy for ISP	–	1.12
EBBE	(unused)	–	0
FC	Forward-bias depletion capacitance limit	–	0.9
GAMM	Epi doping parameter	–	0
HRCF	High current RC factor	–	0
IBBE		–	1e-06
IBCI	Ideal B-C saturation current	A	1e-16
IBCIP	Ideal parasitic B-C saturation current	A	0
IBCN	Nonideal B-C saturation current	A	0
IBCNP	Nonideal parasitic B-C saturation current	A	0
IBEI	Ideal B-E saturation current	A	1e-18
IBEIP	Ideal parasitic B-E saturation current	A	0
IBEN	Nonideal B-E saturation current	A	0
IBENP	Nonideal parasitic B-E saturation current	A	0
IKF	Forward knee current	A	0
IKP	Parasitic knee current	A	0
IKR	Reverse knee current	A	0
IS	Transport saturation current	A	1e-16
ISP	Parasitic transport saturation current	A	0
ISRR	Saturation current for reverse operation	–	1
ITF	Coefficient of $t_f$ dependence on $I_c$	–	0
KFN	B-E flicker (1/f) noise coefficient (unused)	–	0
MC	B-C grading coefficient	–	0.33
ME	B-E grading coefficient	–	0.33
MS	S-C grading coefficient	–	0.33
NBBE		–	1
NCI	Ideal B-C emission coefficient	–	1
NCIP	Ideal parasitic B-C emission coefficient	–	1

Parameter	Description	Units	Default
NCN	Non-ideal B-C emission coefficient	–	2
NCNP	Non-ideal parasitic B-C emission coefficient	–	2
NEI	Ideal B-E emission coefficient	–	1
NEN	Non-ideal B-E emission coefficient	–	2
NF	Forward emission coefficient	–	1
NFP	Parasitic forward emission coefficient	–	1
NKF		–	0.5
NR	Reverse emission coefficient	–	1
PC	B-C built-in potential	–	0.75
PE	B-E built-in potential	–	0.75
PS	S-C built-in potential	–	0.75
QBM		–	0
QCO	Epi charge parameter	C	0
QTF	Variation of $t_f$ with base width modulation	–	0
RBI	Intrinsic base resistance	$\Omega$	0
RBP	Parasitic base resistance	$\Omega$	0
RBX	Extrinsic base resistance	$\Omega$	0
RCI	Intrinsic Collector resistance	$\Omega$	0
RCX	Extrinsic Collector resistance	$\Omega$	0
RE	Emitter resistance	$\Omega$	0
RS	Substrate resistance	$\Omega$	0
RTH	Thermal resistance, must be given for self-heating	$\Omega$	0
TAVC	Temperature coefficient of $A_{vc2}$	–	0
TD	Forward excess-phase delay time (unused in this version)	–	0
TF	Forward transit time	s	0
TNBBE		–	0
TNF	Temperature coefficient of $N_f$	–	0
TNOM	Nominal temperature	$^{\circ}\text{C}$	27
TR	Reverse transit time	–	0

Parameter	Description	Units	Default
TVBBE1		–	0
TVBBE2		–	0
VBBE		–	0
VEF	Forward Early voltage	V	0
VER	Reverse Early voltage	V	0
VERS	Version of this VBIC model	–	1.2
V0	Epi drift saturation voltage	V	0
VREV		–	0
VRT		–	0
VTF	Coefficient of $t_f$ dependence on $V_{bc}$	–	0
WBE	Portion of $I_{bei}$ from $V_{bei}$	–	1
WSP	Portion of $I_{ccp}$ from $V_{bep}$	–	1
XII	Temperature exponent of $I_{bei}$ , $I_{bci}$ , $I_{beip}$ , and $I_{bcip}$	–	3
XIKF		–	0
XIN	Temperature exponent of $I_{ben}$ , $I_{bcn}$ , $I_{benp}$ , and $I_{bcnp}$	–	3
XIS	Temperature exponent of $I_S$	–	3
XISR	Temperature exponent of $I_{SRR}$	–	0
XRBI		–	0
XRBP		–	0
XRBX		–	0
XRCI		–	0
XRCX		–	0
XRE	Temperature exponent of $r_e$	–	0
XRS	Temperature exponent of $r_s$	–	0
XTF	Coefficient of $t_f$ with bias dependence	–	0
XV0	Temperature exponent of $v_0$	–	0

Table 2.21: VBIC Device Model Parameters.

## BJT Equations

The BJT implementation within **Xyce** is based on [1]. The equations in this section describe an NPN transistor. For the PNP device, reverse the signs of all voltages and currents. The equations use the following variables:

$V_{be}$	=	intrinsic base-intrinsic emitter voltage
$V_{bc}$	=	intrinsic base-intrinsic collector voltage
$V_{bs}$	=	intrinsic base-substrate voltage
$V_{bw}$	=	intrinsic base-extrinsic collector voltage (quasi-saturation only)
$V_{bx}$	=	extrinsic base-intrinsic collector voltage
$V_{ce}$	=	intrinsic collector-intrinsic emitter voltage
$V_{js}$	=	(NPN) intrinsic collector-substrate voltage = (PNP) intrinsic substrate-collector voltage
$V_t$	=	$kT/q$ (thermal voltage)
$V_{th}$	=	threshold voltage
$k$	=	Boltzmann's constant
$q$	=	electron charge
$T$	=	analysis temperature (K)
$T_0$	=	nominal temperature (set using TNOM option)

Other variables are listed above in BJT Model Parameters.

### DC Current

The BJT model is based on the Gummel and Poon model [8] where the different terminal currents are written

$$\begin{aligned}
 I_e &= -I_{cc} - I_{be} + I_{re} + (C_{dife} + C_{de}) \frac{dV_{be}}{dt} \\
 I_c &= -I_{cc} + I_{bc} - I_{rc} - (C_{difc} + C_{dc}) \frac{dV_{bc}}{dt} \\
 I_b &= I_e - I_c
 \end{aligned}$$

Here,  $C_{dife}$  and  $C_{difc}$  are the capacitances related to the hole charges per unit area in the base,  $Q_{dife}$  and  $Q_{difc}$ , affiliated with the electrons introduced across the emitter-base and collector-base junctions, respectively. Also,  $C_{be}$  and  $C_{bc}$  are the capacitances related to donations to the hole charge of the base,  $Q_{be}$  and  $Q_{bc}$ , affiliated with the differences in the depletion regions of the emitter-base and collector-base junctions, respectively. The

intermediate currents used are defined as

$$\begin{aligned}
 -I_{be} &= \frac{\mathbf{IS}}{\mathbf{BF}} \left[ \exp\left(\frac{V_{be}}{\mathbf{NF}V_{th}}\right) - 1 \right] \\
 -I_{cc} &= \frac{Q_{bo}}{Q_b} \mathbf{IS} \left[ \exp\left(\frac{V_{be}}{\mathbf{NF}V_{th}}\right) - \exp\left(\frac{V_{bc}}{\mathbf{NF}V_{th}}\right) \right] \\
 -I_{bc} &= \frac{\mathbf{IS}}{\mathbf{BR}} \left[ \exp\left(\frac{V_{bc}}{\mathbf{NR}V_{th}}\right) - 1 \right] \\
 I_{re} &= \mathbf{ISE} \left[ \exp\left(\frac{V_{be}}{\mathbf{NE}V_{th}}\right) - 1 \right] \\
 I_{rc} &= \mathbf{ISC} \left[ \exp\left(\frac{V_{bc}}{\mathbf{NC}V_{th}}\right) - 1 \right]
 \end{aligned}$$

where the last two terms are the generation/recombination currents related to the emitter and collector junctions, respectively. The charge  $Q_b$  is the majority carrier charge in the base at large injection levels and is a key difference in the Gummel-Poon model over the earlier Ebers-Moll model. The ratio  $Q_b/Q_{bo}$  (where  $Q_{bo}$  represents the zero-bias base charge, i.e. the value of  $Q_b$  when  $V_{be} = V_{bc} = 0$ ) as computed by Xyce is given by

$$\frac{Q_b}{Q_{bo}} = \frac{q_1}{2} \left( 1 + \sqrt{1 + 4q_2} \right)$$

where

$$\begin{aligned}
 q_1 &= \left( 1 - \frac{V_{be}}{\mathbf{VAR}} - \frac{V_{bc}}{\mathbf{VAF}} \right)^{-1} \\
 q_2 &= \frac{\mathbf{IS}}{\mathbf{IKF}} \left[ \exp\left(\frac{V_{be}}{\mathbf{NF}V_{th}}\right) - 1 \right] + \frac{\mathbf{IS}}{\mathbf{IKR}} \left[ \exp\left(\frac{V_{bc}}{\mathbf{NR}V_{th}}\right) - 1 \right]
 \end{aligned}$$

### Capacitance Terms

The capacitances listed in the above DC  $I - V$  equations each consist of a depletion layer capacitance  $C_d$  and a diffusion capacitance  $C_{dif}$ . The first is given by

$$C_d = \begin{cases} \mathbf{CJ} \left( 1 - \frac{V_{di}}{\mathbf{VJ}} \right)^{-\mathbf{M}} & V_{di} \leq \mathbf{FC} \cdot \mathbf{VJ} \\ \mathbf{CJ} (1 - \mathbf{FC})^{-(1+\mathbf{M})} \left[ 1 - \mathbf{FC}(1 + \mathbf{M}) + \mathbf{M} \frac{V_{di}}{\mathbf{VJ}} \right] & V_{di} > \mathbf{FC} \cdot \mathbf{VJ} \end{cases}$$

where  $\mathbf{CJ} = \mathbf{CJE}$  for  $C_{de}$ , and where  $\mathbf{CJ} = \mathbf{CJC}$  for  $C_{dc}$ . The diffusion capacitance (sometimes referred to as the transit time capacitance) is

$$C_{dif} = \mathbf{TT}G_d = \mathbf{TT} \frac{dI}{dV_{di}}$$

where  $I$  is the diode DC current given,  $G_d$  is the corresponding junction conductance, and where  $\mathbf{TT} = \mathbf{TF}$  for  $C_{dife}$  and  $\mathbf{TT} = \mathbf{TR}$  for  $C_{difc}$ .

### Temperature Effects

Spice temperature effects are default, but all levels of the BJT have a more advanced temperature compensation available. By specifying `TEMPMODEL=QUADRATIC` in the netlist, parameters can be interpolated quadratically between measured values extracted from data. In the BJT, `IS` and `ISE` are interpolated logarithmically because they can change over an order of magnitude or more for temperature ranges of interest. See Section 5.3 of the User's Guide for more details on how to include quadratic temperature effects.

For further information on BJT models, see [8]. For a thorough description of the U.C. Berkeley SPICE models see Reference [9].

## Junction Field-Effect Transistor (JFET)

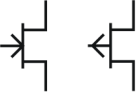
<b>General Form</b>	J<name> <drain node> <gate node> <source node> <model name> + [area value] [device parameters]
<b>Examples</b>	JIN 100 1 0 JFAST J13 22 14 23 JNOM 2.0 J1 1 2 0 2N5114
<b>Symbols</b>	
<b>Model Form</b>	.MODEL <model name> NJF [model parameters] .MODEL <model name> PJF [model parameters]
	<drain node> Node connected to drain.
	<gate node> Node connected to gate.
	<source node> Node connected to source.
<b>Parameters and Options</b>	<source node> Name of model defined in .MODEL line. [area value] The JFET is modeled as an intrinsic FET using an ohmic resistance (RD/area) in series with the drain and another ohmic resistance (RS/area) in series with the source. area is an area factor with a default of 1. [device parameters] Parameters listed in Table 2.22 may be provided as space separated <parameter>=<value> specifications as needed. Any number of parameters may be specified.

**Comments**

The JFET was first proposed and analyzed by Shockley. The SPICE-compatible JFET model is an approximation to the Shockley analysis that employs an adjustable parameter B. Both the Shockley formulation and the SPICE approximation are available in Xyce.

**Device Parameters**

Table 2.22 gives the available device parameters for the JFET.

Parameter	Description	Units	Default
AREA	device area	m <sup>2</sup>	1
TEMP	Device temperature	°C	27

Table 2.22: JFET Device Parameters.

**Model Parameters**

Table 2.23 gives the available model parameters for the JFET.

Parameter	Description	Units	Default
AF	Flicker noise exponent	–	1
B	Doping tail parameter (level 1)	V <sup>-1</sup>	1
BETA	Transconductance parameter	A/V <sup>2</sup>	0.0001
CGD	Zero-bias gate-drain junction capacitance	F	0
CGS	Zero-bias gate-source junction capacitance	F	0
DELTA	Saturation voltage parameter (level 2)	V	0
FC	Coefficient for forward-bias depletion capacitance	F	0.5
IS	Gate junction saturation current	A	1e-14
KF	Flicker noise coefficient	–	0.05
LAMBDA	Channel length modulation	V <sup>-1</sup>	0
PB	Gate junction potential	V	1
RD	Drain ohmic resistance	Ω	0

Parameter	Description	Units	Default
RS	Source ohmic resistance	$\Omega$	0
TEMPMODEL	Specification to type of parameter interpolation over temperature (see User Guide section 5.3	–	NONE
THETA	Mobility modulation parameter (level 2)	$V^{-1}$	0
TNOM	Nominal device temperature	$^{\circ}C$	27
VTO	Threshold voltage	V	-2

Table 2.23: JFET Model Parameters.

### JFET Level selection

**Xyce** supports two JFET models. LEVEL=1, the default, is the SPICE 3f5 treatment. This model employs a doping profile parameter B. When B=1, the original SPICE square law is exactly implemented, and when B=0.6 the model is close to that of Shockley.

When LEVEL=2 is selected, the Shockley model is used with some additional physics effects: channel length modulation and the effect of gate electric field on mobility. An additional parameter, DELTA, is added to the LEVEL 2 model that allows the user to adjust the saturation voltage.

## Metal-Semiconductor FET (MESFET)

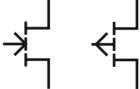
<b>General Form</b>	Z<name> < drain node> <gate node> <source node> <model name> + [area value] [device parameters]
<b>Examples</b>	Z1 2 3 0 MESMOD AREA=1.4 Z1 7 2 3 ZM1
<b>Symbols</b>	
<b>Model Form</b>	.MODEL <model name> NMF [model parameters] .MODEL <model name> PMF [model parameters]
	<drain node> Node connected to drain.
	<gate node> Node connected to gate.
	<source node> Node connected to source.
<b>Parameters and Options</b>	<source node> Name of model defined in .MODEL line. [area value] The MESFET is modeled as an intrinsic FET using an ohmic resistance ( $R_D/area$ ) in series with the drain and another ohmic resistance ( $R_S/area$ ) in series with the source. area is an area factor with a default of 1. [device parameters] Parameters listed in Table 2.24 may be provided as space separated <parameter>=<value> specifications as needed. Any number of parameters may be specified.

**Comments**

Although MESFETs can be made of Si, such devices are not as common as GaAs MESFETS. And since the mobility of electrons is much higher than holes in GaAs, nearly all commercial devices are n-type MESFETS.

**Device Parameters**

Table 2.24 gives the available device parameters for the MESFET.

Parameter	Description	Units	Default
AREA	device area	m <sup>2</sup>	1
TEMP	Device temperature	°C	27

Table 2.24: MESFET Device Parameters.

**Model Parameters**

Table 2.25 gives the available model parameters for the MESFET.

Parameter	Description	Units	Default
AF	Flicker noise exponent	–	1
ALPHA	Saturation voltage parameter	V <sup>-1</sup>	2
B	Doping tail parameter	V <sup>-1</sup>	0.3
BETA	Transconductance parameter	A/V <sup>2</sup>	0.0025
CGD	Zero-bias gate-drain junction capacitance	F	0
CGS	Zero-bias gate-source junction capacitance	F	0
FC	Coefficient for forward-bias depletion capacitance	F	0.5
IS	Gate junction saturation current	A	1e-14
KF	Flicker noise coefficient	–	0.05
LAMBDA	Channel length modulation	V <sup>-1</sup>	0
PB	Gate junction potential	V	1
RD	Drain ohmic resistance	Ω	0

Parameter	Description	Units	Default
RS	Source ohmic resistance	$\Omega$	0
TEMPMODEL	Specification to type of parameter interpolation over temperature (see User Guide section 5.3	–	NONE
TNOM	Nominal device temperature	$^{\circ}\text{C}$	27
VTO	Threshold voltage	V	0

Table 2.25: MESFET Model Parameters.

### MESFET Level selection

**Xyce** supports two MESFET models. LEVEL=1, the default, is the SPICE 3f5 treatment. This model employs a doping profile parameter B. When B=1, the original SPICE square law is exactly implemented, and when B=0.6 the model is close to that of Shockley.

When LEVEL=2 is selected, the Shockley model is used with some additional physics effects: channel length modulation and the effect of gate electric field on mobility. An additional parameter, DELTA, is added to the LEVEL 2 model that allows the user to adjust the saturation voltage.

## MOS Field Effect Transistor (MOSFET)

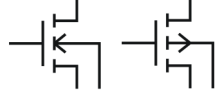
<b>General Form</b>	<pre>M&lt;name&gt; &lt;drain node&gt; &lt;gate node&gt; &lt;source node&gt; + &lt;bulk/substrate node&gt; &lt;model name&gt; + [L=&lt;value&gt;] [W=&lt;value&gt;] + [AD=&lt;value&gt;] [AS=&lt;value&gt;] + [PD=&lt;value&gt;] [PS=&lt;value&gt;] + [NRD=&lt;value&gt;] [NRS=&lt;value&gt;] + [M=&lt;value&gt;] [IC=&lt;value, ...&gt;]</pre>
<b>Special Form (BSIMSOI)</b>	<pre>M&lt;name&gt; &lt;drain node&gt; &lt;gate node&gt; &lt;source node&gt; + &lt;substrate node (E)&gt; + [&lt;External body contact (P)&gt;] + [&lt;internal body contact (B)&gt;] + [&lt;temperature node (T)&gt;] + &lt;model name&gt; + [L=&lt;value&gt;] [W=&lt;value&gt;] + [AD=&lt;value&gt;] [AS=&lt;value&gt;] + [PD=&lt;value&gt;] [PS=&lt;value&gt;] + [NRD=&lt;value&gt;] [NRS=&lt;value&gt;] [NRB=&lt;value&gt;] + [BJTOFF=&lt;value&gt;] + [IC=&lt;val&gt;, &lt;val&gt;, &lt;val&gt;, &lt;val&gt;, &lt;val&gt;] + [RTHO=&lt;val&gt;] [CTHO=&lt;val&gt;] + [NBC=&lt;val&gt;] [NSEG=&lt;val&gt;] [PDBCP=&lt;val&gt;] [PSBCP=&lt;val&gt;] + [AGBCP=&lt;val&gt;] [AEBCP=&lt;val&gt;] [VBSUSR=&lt;val&gt;] [TNODEOUT] + [FRBODY=&lt;val&gt;] [M=&lt;value&gt;]</pre>
<b>Examples</b>	<pre>M5 4 12 3 0 PNOM L=20u W=10u M3 5 13 10 0 PSTRONG M6 7 13 10 0 PSTRONG M=2 M8 10 12 100 100 NWEAK L=30u W=20u + AD=288p AS=288p PD=60u PS=60u NRD=14 NRS=24</pre>
<b>Symbols</b>	
<b>Model Form</b>	<pre>.MODEL &lt;model name&gt; NMOS [model parameters] .MODEL &lt;model name&gt; PMOS [model parameters]</pre>

---

**Parameters  
and Options**

---

L and W

The MOSFET channel length and width that are decreased to get the actual channel length and width. They may be given in the device .MODEL or .OPTIONS statements. The value in the device statement overrides the value in the model statement, which overrides the value in the .OPTIONS statement. Defaults for L and W may be set in the .OPTIONS statement. If L or W values are not given, their default value is 100 u.

AD and AS

The drain and source diffusion areas. Defaults for AD and AS can be set in the .OPTIONS statement. If AD or AS defaults are not set, their default value is 0.

PD and PS

The drain and source diffusion perimeters. Their default value is 0.

---

---

 NRD, NRS

Multipliers (in units of squares) that can be multiplied by  $R_{SH}$  to yield the parasitic (ohmic) resistances of the drain ( $R_D$ ) and source ( $R_S$ ), respectively. NRD, NRS default to 0.

Consider a square sheet of resistive material. Analysis shows that the resistance between two parallel edges of such a sheet depends upon its composition and thickness, but is independent of its size as long as it is square. In other words, the resistance will be the same whether the square's edge is 2 mm, 2 cm, or 2 m. For this reason, the sheet resistance of such a layer, abbreviated  $R_{SH}$ , has units of ohms per square.

M

If specified, the value is used as a number of parallel MOSFETs to be simulated. For example, if  $M=2$  is specified, we simulate two identical mosfets connected to the same nodes in parallel.

**Parameters**  
**and Options (cont.)**

IC

The BSIM3 (model level 9), BSIM4 (model level 14) and BSIMSOI (model level 10) allow one to specify the initial voltage difference across nodes of the device during the DC operating point calculation. For the BSIM3 and BSIM4 the syntax is  $IC= V_{ds}, V_{gs}, V_{bs}$  where  $V_{ds}$  is the voltage difference between the drain and source,  $V_{gs}$  is the voltage difference between the gate and source and  $V_{bs}$  is the voltage difference between the body and source. The BSIMSOI device's initial condition syntax is  $IC= V_{ds}, V_{gs}, V_{bs}, V_{es}, V_{ps}$  where the two extra terms are the voltage difference between the substrate and source, and the external body and source nodes respectively. Note that for any of these lists of voltage differences, fewer than the full number of options may be specified.

For example, IC=5.0 specifies an initial condition on  $V_{ds}$  but does not specify any initial conditions on the other nodes. Therefore, one cannot specify  $V_{gs}$  without specifying  $V_{ds}$ , etc. It is illegal to specify initial conditions on any nodes that are tied together. Xyce attempts to catch such errors, but complex circuits may stymie this error trap.

---

---

There are a large number of extra instance parameters and optional nodes available for the BSIMSOI (level 10) MOSFET.

substrate node

The fourth node of the BSIMSOI device is always the substrate node, which is referred to as the E node.

external body contact node

If given, the fifth node is the external body contact node, P. It is connected to the internal body node through a body tie resistor. If P is not given, the internal body node is not accessible from the netlist and floats.

If there are only five nodes specified and TNODEOUT is also specified, the fifth node is the temperature node instead.

internal body contact node

If given, the sixth node is the internal body contact node, B. It is connected to the external body node through a body tie resistor. If B is not given and P is given, the internal body node is not accessible from the netlist, but is still tied to the external body contact through the tie resistance.

If there are only six nodes specified and TNODEOUT is also specified, the sixth node is the temperature node instead.

temperature node

If the parameter TNODEOUT is specified, the final node (fifth, sixth, or seventh) is interpreted as a temperature node. The temperature node is intended for thermal coupling simulation.

BJTOFF

Turns off the parasitic BJT currents.

IC

The IC parameter allows specification of the five junction initial conditions, VDS, VGS, CBS, VES and VPS. VPS is ignored in a four-terminal device.

---

### **BSIMSOI-specific Options**

---

	RTHO	Thermal resistance per unit width. Taken from model card if not given.
	CTHO	Thermal capacitance per unit width. Taken from model card if not given.
	NBC	Number of body contact isolation edge.
	NSEG	Number of segments for channel width partitioning.
	PDBCP	Parasitic perimeter length for body contact at drain side.
<b><u>BSIMSOI-specific</u></b> <b><u>Options (cont.)</u></b>	PSBCP	Parasitic perimeter length for body contact at source side.
	AGBCP	Parasitic gate-to-body overlap area for body contact.
	AEBCP	Parasitic body-to-substrate overlap area for body contact.
	VBSUSR	Optional initial value of VBS specified by user for use in transient analysis. (currently unused in Xyce).
	FRBODY	Layout-dependent body resistance coefficient.

---

<b><u>Comments</u></b>	The simulator provides three MOSFET device models, which differ in the formulation of the I-V characteristic. The LEVEL parameter selects among different models as shown below.
------------------------	--

---

## MOSFET Operating Temperature

Model parameters may be assigned unique measurement temperatures using the TNOM model parameter. See the MOSFET model parameters for more information.

### Model Parameters

Tables 2.26, 2.27, 2.28, 2.29, 2.30, and 2.31 give the available model parameters for the levels 1,2,3,6,9 and 10 MOSFETs, respectively.

#### All MOSFET models

The parameters shared by all MOSFET model levels are principally parasitic element values (e.g., series resistance, overlap capacitance, etc.).

#### Model levels 1, and 3

The DC behaviors of the level 1 and 3 MOSFET models are defined by the parameters VTO, KP, LAMBDA, PHI, and GAMMA. The simulator calculates these if the process parameters (e.g., TOX, and NSUB) are specified, but these are always overridden by any user-defined values. The VTO value is positive (negative) for modeling the enhancement mode and negative (positive) for the depletion mode of N-channel (P-channel) devices.

For MOSFETs, the capacitance model enforces charge conservation, influencing just the Level 1 and 3 models.

Effective device parameter lengths and widths are calculated as follows:

$$P_i = P_0 + P_L/L_e + P_W/W_e$$

where

$$\begin{aligned} L_e &= \text{effective length} &= & \mathbf{L} - (2 \cdot \mathbf{LD}) \\ W_e &= \text{effective width} &= & \mathbf{W} - (2 \cdot \mathbf{WD}) \end{aligned}$$

See .MODEL (model definition) for more information.

#### Model level 9 (BSIM3 version 3.2.2)

The University of California, Berkeley BSIM3 model is a physical-based model with a large number of dependencies on essential dimensional and processing parameters. It incorporates the key effects that are critical in modeling deep-submicrometer MOSFETs. These include threshold voltage reduction, nonuniform doping, mobility reduction due to the vertical

field, bulk charge effect, carrier velocity saturation, drain-induced barrier lowering (DIBL), channel length modulation (CLM), hot-carrier-induced output resistance reduction, sub-threshold conduction, source/drain parasitic resistance, substrate current induced body effect (SCBE) and drain voltage reduction in LDD structure.

The BSIM3 Version 3.2.2 model is a deep submicron MOSFET model with several major enhancements (over earlier versions). These include a single I-V formula used to define the current and output conductance for operating regions, improved narrow width device modeling, a superior capacitance model with improved short and narrow geometry models, a new relaxation-time model to better transient modeling and enhanced model fitting of assorted W/L ratios using a single parameter set. This version preserves the large number of integrated dependencies on dimensional and processing parameters of the Version 2 model. For further information, see Reference [10].

#### Additional notes

1. If any of the following BSIM3 3.2.2 model parameters are not specified, they are computed via the following:

If **VTHO** is not specified, then:

$$\mathbf{VTHO} = \mathbf{VFB} + \phi_s \mathbf{K1} \sqrt{\phi_s}$$

where:

$$\mathbf{VFB} = -1.0$$

If **VTHO** is given, then:

$$\mathbf{VFB} = \mathbf{VTHO} - \phi_s + \mathbf{K1} \sqrt{phi_s}$$

$$\mathbf{VBX} = \phi_s - \frac{q \cdot \mathbf{NCH} \cdot \mathbf{XT}^2}{2\epsilon_{si}}$$

$$\mathbf{CF} = \left( \frac{2\epsilon_{ox}}{\pi} \right) \ln \left( 1 + \frac{1}{4 \times 10^7 \cdot \mathbf{TOX}} \right)$$

where:

$$E_g(T) = \text{the energy bandgap at temperature } T = 1.16 - \frac{T^2}{7.02 \times 10^4 (T + 1108)}$$

2. If **K1** and **K2** are not given then they are computed via the following:

$$\mathbf{K1} = \mathbf{GAMMA2} - 2 \cdot \mathbf{K2} \sqrt{\phi_s - \mathbf{VBM}}$$

$$\mathbf{K2} = \frac{(\mathbf{GAMMA1} - \mathbf{GAMMA2})(\sqrt{\phi_s - \mathbf{VBX}} - \sqrt{\phi_s})}{2\sqrt{\phi_s}(\sqrt{\phi_s - \mathbf{VBM}} - \sqrt{\phi_s}) + \mathbf{VBM}}$$

where:

$$\begin{aligned}\phi_s &= 2V_t \ln\left(\frac{\mathbf{NCH}}{n_i}\right) \\ V_t &= kT/q \\ n_i &= 1.45 \times 10^{10} \left(\frac{T}{300.15}\right)^{1.5} \exp\left(21.5565981 - \frac{E_g(T)}{2V_t}\right)\end{aligned}$$

3. If **NCH** is not specified and **GAMMA1** is, then:

$$\mathbf{NCH} = \frac{\mathbf{GAMMA1}^2 \times \mathbf{COX}^2}{2q\varepsilon_{si}}$$

If **GAMMA1** and **NCH** are not specified, then **NCH** defaults to  $1.7 \times 10^{23} \text{ m}^{-3}$  and **GAMMA1** is computed using **NCH**:

$$\mathbf{GAMMA1} = \frac{\sqrt{2q\varepsilon_{si} \cdot \mathbf{NCH}}}{\mathbf{COX}}$$

If **GAMMA2** is not specified, then:

$$\mathbf{GAMMA2} = \frac{\sqrt{2q\varepsilon_{si} \cdot \mathbf{NSUB}}}{\mathbf{COX}}$$

4. If **CGSO** is not specified and **DLC** > 0, then:

$$\mathbf{CGSO} = \begin{cases} 0, & ((\mathbf{DLC} \cdot \mathbf{COX}) - \mathbf{CGSL}) < 0 \\ 0.6 \cdot \mathbf{XJ} \cdot \mathbf{COX}, & ((\mathbf{DLC} \cdot \mathbf{COX}) - \mathbf{CGSL}) \geq 0 \end{cases}$$

5. If **CGDO** is not specified and **DLC** > 0, then:

$$\mathbf{CGDO} = \begin{cases} 0, & ((\mathbf{DLC} \cdot \mathbf{COX}) - \mathbf{CGSL}) < 0 \\ 0.6 \cdot \mathbf{XJ} \cdot \mathbf{COX}, & ((\mathbf{DLC} \cdot \mathbf{COX}) - \mathbf{CGSL}) \geq 0 \end{cases}$$

#### Model level 10 (BSIMSOI version 3.2)

The BSIMSOI is an international standard model for SOI (silicon on insulator) circuit design and is formulated on top of the BSIM3v3 framework. A detailed description can be found in the BSIMSOI 3.1 Users' Manual [11] and the BSIMSOI 3.2 release notes [12].

This version (v3.2) of the BSIMSOI includes three depletion models; the partially depleted BSIMSOI PD (soiMod=0), the fully depleted BSIMSOI FD (soiMod=2), and the unified SOI model (soiMod=1).

BSIMPD is the Partial-Depletion (PD) mode of the BSIMSOI. A typical PD SOI MOSFET is formed on a thin SOI film which is layered on top of a buried oxide. BSIMPD has the following features and enhancements:

- Real floating body simulation of both I-V and C-V. The body potential is determined by the balance of all body current components.
- An improved parasitic bipolar current model. This includes enhancements in the various diode leakage components, second order effects (high-level injection and Early effect), diffusion charge equation, and temperature dependence of the diode junction capacitance.
- An improved impact-ionization current model. The contribution from BJT current is also modeled by the parameter Fbjtii.
- A gate-to-body tunneling current model, which is important to thin-oxide SOI technologies.
- Enhancements in the threshold voltage and bulk charge formulation of the high positive body bias regime.
- Instance parameters (Pdbcp, Psbcp, Agbcp, Aebcp, Nbc) are provided to model the parasitics of devices with various body-contact and isolation structures.
- An external body node (the 6th node) and other improvements are introduced to facilitate the modeling of distributed body resistance.
- Self heating. An external temperature node (the 7th node) is supported to facilitate the simulation of thermal coupling among neighboring devices.
- A unique SOI low frequency noise model, including a new excess noise resulting from the floating body effect.
- Width dependence of the body effect is modeled by parameters (K1,K1w1,K1w2).
- Improved history dependence of the body charges with two new parameters (Fbody, DLCB).
- An instance parameter Vbsusr is provided for users to set the transient initial condition of the body potential.
- The new charge-thickness capacitance model introduced in BSIM3v3.2, capMod=3, is included.

The following tables gives the parameters for the MOSFET, levels 1 through 10.

Level=1 Parameter	Description	Units	Default
<b>Capacitance Parameters</b>			
CBD	Zero-bias bulk-drain p-n capacitance	F	0
CBS	Zero-bias bulk-source p-n capacitance	F	0
CGBO	Gate-bulk overlap capacitance/channel length	F/m	0
CGDO	Gate-drain overlap capacitance/channel width	F/m	0
CGSO	Gate-source overlap capacitance/channel width	F/m	0
CJ	Bulk p-n zero-bias bottom capacitance/area	F/m <sup>2</sup>	0
CJSW	Bulk p-n zero-bias sidewall capacitance/area	F/m <sup>2</sup>	0
FC	Bulk p-n forward-bias capacitance coefficient	–	0.5
<b>Control Parameters</b>			
TEMPMODEL	Specification to type of parameter interpolation over temperature (see User Guide section 5.3	–	NONE
<b>Current Parameters</b>			
IS	Bulk p-n saturation current	A	1e-14
<b>Doping Parameters</b>			
LD	Lateral diffusion length	m	0
MJ	Bulk p-n bottom grading coefficient	–	0.5
MJSW	Bulk p-n sidewall grading coefficient	–	0.5
NSUB	Substrate doping density	cm <sup>-3</sup>	0
<b>Flicker Parameters</b>			
AF	Flicker noise exponent	–	1
KF	Flicker noise coefficient	–	0
<b>Geometry Parameters</b>			
L	Default channel length	m	0.0001
TOX	Gate oxide thickness	m	1e-07
W	Default channel width	m	0.0001
<b>Material Parameters</b>			
TPG	Gate material type (-1 = same as substrate, 0 = aluminum, 1 = opposite of substrate	–	0
<b>Resistance Parameters</b>			
RD	Drain ohmic resistance	Ω	0
RS	Source ohmic resistance	Ω	0

Level=1 Parameter	Description	Units	Default
RSH	Drain, source diffusion sheet resistance	$\Omega$	0
<b><i>Process Parameters</i></b>			
GAMMA	Bulk threshold parameter	$V^{1/2}$	0
JS	Bulk p-n saturation current density	$A/m^2$	0
KP	Transconductance coefficient	$A/V^2$	2e-05
LAMBDA	Channel-length modulation	$V^{-1}$	0
NSS	Surface state density	$cm^{-2}$	0
PHI	Surface potential	V	0.6
U0	Surface mobility	$1/(Vcm^2s)$	600
<b><i>Temperature Parameters</i></b>			
TNOM	Nominal device temperature	$^{\circ}C$	27
<b><i>Voltage Parameters</i></b>			
PB	Bulk p-n bottom potential	V	0.8
VTO	Zero-bias threshold voltage	V	0

Table 2.26: MOSFET level 1 Device Model Parameters.

Level=2 Parameter	Description	Units	Default
DELTA	Width effect on threshold	–	0
NEFF	Total channel charge coeff.	–	1
NFS	Fast surface state density	–	0
UCRIT	Crit. field for mob. degradation	–	10000
UEXP	Crit. field exp for mob. deg.	–	0
VMAX	Maximum carrier drift velocity	–	0
XJ	Junction depth	–	0
<b>Capacitance Parameters</b>			
CBD	Zero-bias bulk-drain p-n capacitance	F	0
CBS	Zero-bias bulk-source p-n capacitance	F	0
CGBO	Gate-bulk overlap capacitance/channel length	F/m	0
CGDO	Gate-drain overlap capacitance/channel width	F/m	0
CGSO	Gate-source overlap capacitance/channel width	F/m	0
CJ	Bulk p-n zero-bias bottom capacitance/area	F/m <sup>2</sup>	0
CJSW	Bulk p-n zero-bias sidewall capacitance/area	F/m <sup>2</sup>	0
FC	Bulk p-n forward-bias capacitance coefficient	–	0.5
<b>Control Parameters</b>			
TEMPMODEL	Specification to type of parameter interpolation over temperature (see User Guide section 5.3	–	NONE
<b>Current Parameters</b>			
IS	Bulk p-n saturation current	A	1e-14
<b>Doping Parameters</b>			
LD	Lateral diffusion length	m	0
MJ	Bulk p-n bottom grading coefficient	–	0.5
MJSW	Bulk p-n sidewall grading coefficient	–	0.5
NSUB	Substrate doping density	cm <sup>-3</sup>	0
<b>Flicker Parameters</b>			
AF	Flicker noise exponent	–	1
KF	Flicker noise coefficient	–	0
<b>Geometry Parameters</b>			
L	Default channel length	m	0.0001

Level=2 Parameter	Description	Units	Default
TOX	Gate oxide thickness	m	1e-07
W	Default channel width	m	0.0001
<b>Material Parameters</b>			
TPG	Gate material type (-1 = same as substrate, 0 = aluminum, 1 = opposite of substrate)	–	0
<b>Resistance Parameters</b>			
RD	Drain ohmic resistance	$\Omega$	0
RS	Source ohmic resistance	$\Omega$	0
RSH	Drain, source diffusion sheet resistance	$\Omega$	0
<b>Process Parameters</b>			
GAMMA	Bulk threshold parameter	$V^{1/2}$	0
JS	Bulk p-n saturation current density	$A/m^2$	0
KP	Transconductance coefficient	$A/V^2$	2.07189e-05
LAMBDA	Channel-length modulation	$V^{-1}$	0
NSS	Surface state density	$cm^{-2}$	0
PHI	Surface potential	V	0.6
U0	Surface mobility	$1/(Vcm^2s)$	600
<b>Temperature Parameters</b>			
TNOM	Nominal device temperature	$^{\circ}C$	27
<b>Voltage Parameters</b>			
PB	Bulk p-n bottom potential	V	0.8
VTO	Zero-bias threshold voltage	V	0

Table 2.27: MOSFET level 2 Device Model Parameters.

Level=3 Parameter	Description	Units	Default
KAPPA	Saturation field factor	–	0.2
<b>Capacitance Parameters</b>			
CBD	Zero-bias bulk-drain p-n capacitance	F	0
CBS	Zero-bias bulk-source p-n capacitance	F	0
CGBO	Gate-bulk overlap capacitance/channel length	F/m	0
CGDO	Gate-drain overlap capacitance/channel width	F/m	0
CGSO	Gate-source overlap capacitance/channel width	F/m	0
CJ	Bulk p-n zero-bias bottom capacitance/area	F/m <sup>2</sup>	0
CJSW	Bulk p-n zero-bias sidewall capacitance/area	F/m <sup>2</sup>	0
FC	Bulk p-n forward-bias capacitance coefficient	–	0.5
<b>Control Parameters</b>			
TEMPMODEL	Specification to type of parameter interpolation over temperature (see User Guide section 5.3	–	NONE
<b>Current Parameters</b>			
IS	Bulk p-n saturation current	A	1e-14
<b>Doping Parameters</b>			
LD	Lateral diffusion length	m	0
MJ	Bulk p-n bottom grading coefficient	–	0.5
MJSW	Bulk p-n sidewall grading coefficient	–	0.33
NSUB	Substrate doping density	cm <sup>-3</sup>	0
<b>Flicker Parameters</b>			
AF	Flicker noise exponent	–	1
KF	Flicker noise coefficient	–	0
<b>Geometry Parameters</b>			
L	Default channel length	m	0.0001
TOX	Gate oxide thickness	m	1e-07
W	Default channel width	m	0.0001
XJ	Metallurgical junction depth	m	0
<b>Material Parameters</b>			
TPG	Gate material type (-1 = same as substrate, 0 = aluminum, 1 = opposite of substrate	–	1
<b>Resistance Parameters</b>			

Level=3 Parameter	Description	Units	Default
RD	Drain ohmic resistance	$\Omega$	0
RS	Source ohmic resistance	$\Omega$	0
RSH	Drain, source diffusion sheet resistance	$\Omega$	0
<b>Process Parameters</b>			
DELTA	Width effect on threshold	–	0
ETA	Static feedback	–	0
GAMMA	Bulk threshold parameter	$V^{1/2}$	0
JS	Bulk p-n saturation current density	$A/m^2$	0
KP	Transconductance coefficient	$A/V^2$	2.07189e-05
NFS	Fast surface state density	$cm^{-2}$	0
NSS	Surface state density	$cm^{-2}$	0
PHI	Surface potential	V	0.6
THETA	Mobility modulation	$V^{-1}$	0
U0	Surface mobility	$1/(Vcm^2s)$	600
VMAX	Maximum drift velocity	m/s	0
<b>Temperature Parameters</b>			
TNOM	Nominal device temperature	$^{\circ}C$	27
<b>Voltage Parameters</b>			
PB	Bulk p-n bottom potential	V	0.8
VTO	Zero-bias threshold voltage	V	0

Table 2.28: MOSFET level 3 Device Model Parameters.

Level=6 Parameter	Description	Units	Default
GAMMA	Bulk threshold parameter	–	0
GAMMA1	Bulk threshold parameter 1	–	0
KC	Saturation current factor	–	5e-05
KV	Saturation voltage factor	–	2
LAMBDA	Channel length modulation param.	–	0
LAMBDA0	Channel length modulation param. 0	–	0
LAMBDA1	Channel length modulation param. 1	–	0
NC	Saturation current coeff.	–	1
NV	Saturation voltage coeff.	–	0.5
NVTH	Threshold voltage coeff.	–	0.5
PS	Sat. current modification par.	–	0
SIGMA	Static feedback effect par.	–	0
<b>Capacitance Parameters</b>			
CBD	Zero-bias bulk-drain p-n capacitance	F	0
CBS	Zero-bias bulk-source p-n capacitance	F	0
CGBO	Gate-bulk overlap capacitance/channel length	F/m	0
CGDO	Gate-drain overlap capacitance/channel width	F/m	0
CGSO	Gate-source overlap capacitance/channel width	F/m	0
CJ	Bulk p-n zero-bias bottom capacitance/area	F/m <sup>2</sup>	0
CJSW	Bulk p-n zero-bias sidewall capacitance/area	F/m <sup>2</sup>	0
FC	Bulk p-n forward-bias capacitance coefficient	–	0.5
<b>Control Parameters</b>			
TEMPMODEL	Specification to type of parameter interpolation over temperature (see User Guide section 5.3	–	NONE
<b>Current Parameters</b>			
IS	Bulk p-n saturation current	A	1e-14
<b>Doping Parameters</b>			
LD	Lateral diffusion length	m	0
MJ	Bulk p-n bottom grading coefficient	–	0.5
MJSW	Bulk p-n sidewall grading coefficient	–	0.5
NSUB	Substrate doping density	cm <sup>-3</sup>	0

Level=6 Parameter	Description	Units	Default
<b><i>Geometry Parameters</i></b>			
TOX	Gate oxide thickness	m	1e-07
<b><i>Material Parameters</i></b>			
TPG	Gate material type (-1 = same as substrate, 0 = aluminum, 1 = opposite of substrate)	–	1
<b><i>Resistance Parameters</i></b>			
RD	Drain ohmic resistance	$\Omega$	0
RS	Source ohmic resistance	$\Omega$	0
RSH	Drain, source diffusion sheet resistance	$\Omega$	0
<b><i>Process Parameters</i></b>			
JS	Bulk p-n saturation current density	A/m <sup>2</sup>	0
NSS	Surface state density	cm <sup>-2</sup>	0
PHI	Surface potential	V	0.6
U0	Surface mobility	1/(Vcm <sup>2</sup> s)	600
<b><i>Temperature Parameters</i></b>			
TNOM	Nominal device temperature	°C	27
<b><i>Voltage Parameters</i></b>			
PB	Bulk p-n bottom potential	V	0.8
VTO	Zero-bias threshold voltage	V	0

Table 2.29: MOSFET level 6 Device Model Parameters.

Level=9 Parameter	Description	Units	Default
<b><i>Bin Parameters</i></b>			
LMAX	Maximum channel length	m	1
LMIN	Minimum channel length	m	0
WMAX	Maximum channel width	m	1
WMIN	Minimum channel width	m	0
<b><i>Capacitance Parameters</i></b>			
ACDE	Exponential coefficient for charge thickness in capmod = 3 for accumulation and depletion regions	m/V	1
CF	Firing field capacitance	F/m	7.29897e-11
CGBO	Gate-bulk overlap capacitance per unit channel length	F/m	0
CGDL	Light-doped drain-gate region overlap capacitance	F/m	0
CGDO	Non-LLD region drain-gate overlap capacitance per unit channel length	F/m	2.07188e-10
CGSL	Light-doped source-gate region overlap capacitance	F/m	0
CGSO	Non-LLD region source-gate overlap capacitance per unit channel length	F/m	2.07188e-10
CJ	Bulk p-n zero-bias bottom capacitance/area	F/m <sup>2</sup>	0.0005
CJSW	Bulk p-n zero-bias sidewall capacitance/area	F/m <sup>2</sup>	5e-10
CJSWG	Source/Drain gate sidewall junction capacitance per unit width	F/m	5e-10
CKAPPA	Coefficient for lightly doped region overlap capacitance firing field capacitance	F/m	0.6
CLC	Constant term for short-channel model	m	1e-07
CLE	Exponential term for the short-channel model	-	0.6
DLC	Length offset fitting parameter from C-V	m	0
DWC	Width offset fitting parameter from C-V	m	0
LACDE	Length dependence of ACDE	m <sup>2</sup> /V	0
LCF	Length dependence of CF	F	0
LCGDL	Length dependence of CGDL	F	0
LCGSL	Length dependence of CGSL	F	0
LCKAPPA	Length dependence of CKAPPA	F	0

Level=9 Parameter	Description	Units	Default
LCLC	Length dependence of CLC	m <sup>2</sup>	0
LCLE	Length dependence of CLE	m	0
LMOIN	Length dependence of MOIN	m	0
LNOFF	Length dependence of NOFF	m	0
LVFBCV	Length dependence of VFBCV	Vm	0
LVOFFCV	Length dependence of VOFFCV	Vm	0
MJSWG	Source/Drain gate sidewall junction capacitance grading coefficient	–	0.33
MOIN	Coefficient for the gate-bias dependent surface potential	–	15
NOFF	CV parameter in Vgsteff, CV for weak to strong inversion	–	1
PACDE	Cross-term dependence of ACDE	m <sup>3</sup> /V	0
PBSW	Source/drain side junction built-in potential	V	1
PBSWG	Source/drain gate sidewall junction built-in potential	V	1
PCF	Cross-term dependence of CF	Fm	0
PCGDL	Cross-term dependence of CGDL	Fm	0
PCGSL	Cross-term dependence of CGSL	Fm	0
PCKAPPA	Cross-term dependence of CKAPPA	Fm	0
PCLC	Cross-term dependence of CLC	m <sup>3</sup>	0
PCLE	Cross-term dependence of CLE	m <sup>2</sup>	0
PMOIN	Cross-term dependence of MOIN	m <sup>2</sup>	0
PNOFF	Cross-term dependence of NOFF	m <sup>2</sup>	0
PVFBCV	Cross-term dependence of VFBCV	Vm <sup>2</sup>	0
PVOFFCV	Cross-term dependence of VOFFCV	Vm <sup>2</sup>	0
VFBCV	Flat-band voltage parameter (for CAPMOD = 0 only)	V	-1
VOFFCV	CV parameter in Vgsteff, CV for weak to strong inversion	V	0
WACDE	Width dependence of ACDE	m <sup>2</sup> /V	0
WCF	Width dependence of CF	F	0
WCGDL	Width dependence of CGDL	F	0
WCGSL	Width dependence of CGSL	F	0
WCKAPPA	Width dependence of CKAPPA	F	0

Level=9 Parameter	Description	Units	Default
WCLC	Width dependence of CLC	m <sup>2</sup>	0
WCLE	Width dependence of CLE	m	0
WMOIN	Width dependence of MOIN	m	0
WNOFF	Width dependence of NOFF	m	0
WVBCV	Width dependence of VFBCV	Vm	0
WVOFFCV	Width dependence of VOFFCV	Vm	0
XPART	Charge partitioning rate flag	–	0
<b>Control Parameters</b>			
BINUNIT	Binning unit selector	–	1
CAPMOD	Flag for capacitance models	–	3
MOBMOD	Mobility model selector	–	1
NOIMOD	Flag for noise models	–	1
PARAMCHK	Parameter value check	–	0
VERSION	Version number	–	3.2.2
<b>DC Parameters</b>			
A0	Bulk charge effect coefficient for channel length	–	1
A1	First non-saturation effect parameter	V <sup>-1</sup>	0
A2	Second non-saturation factor	–	1
AGS	Gate-bias coefficient of abulk	V <sup>-1</sup>	0
ALPHA0	First parameter of impact-ionization current	m/V	0
ALPHA1	Isub parameter for length scaling	V <sup>-1</sup>	0
B0	Bulk charge effect coefficient for channel width	m	0
B1	Bulk charge effect offset	m	0
BETA0	Second parameter of impact-ionization current	V	30
CDSC	Drain/source to channel coupling capacitance	F/m <sup>2</sup>	0.00024
CDSCB	Body-bias sensitivity of CDSC	F/(Vm <sup>2</sup> )	0
CDSCD	Drain-bias sensitivity of CDSC	F/(Vm <sup>2</sup> )	0
CIT	Interface trap capacitance	F/m <sup>2</sup>	0
DELTA	Effective Vds parameter	V	0.01

Level=9 Parameter	Description	Units	Default
DROUT	L-dependence Coefficient of the DIBL correction parameter in Rout	–	0.56
DSUB	DIBL coefficient exponent in subthreshold region	–	0.56
DVT0	First coefficient of short-channel effect effect on threshold voltage	–	2.2
DVT0W	First coefficient of narrow-width effect effect on threshold voltage for small channel length	m <sup>-1</sup>	0
DVT1	Second coefficient of short-channel effect effect on threshold voltage	–	0.53
DVT1W	Second coefficient of narrow-width effect effect on threshold voltage for small channel length	m <sup>-1</sup>	5.3e+06
DVT2	Body-bias coefficient of short-channel effect effect on threshold voltage	V <sup>-1</sup>	-0.032
DVT2W	Body-bias coefficient of narrow-width effect effect on threshold voltage for small channel length	V <sup>-1</sup>	-0.032
DWB	Coefficient of substrate body bias dependence of Weff	m/V <sup>1/2</sup>	0
DWG	Coefficient of gate dependence of Weff	m/V <sup>1/2</sup>	0
ETA0	DIBL coefficient in subthreshold region	–	0.08
ETAB	Body-bias coefficient for the subthreshold DIBL effect	V <sup>-1</sup>	-0.07
IJTH	Diode limiting current	A	0.1
JSW	Sidewall saturation current per unit length	A/m	0
K1	First-order body effect coefficient	V <sup>1/2</sup>	0
K2	second-order body effect coefficient	–	0
K3	Narrow width coefficient	–	80
K3B	Body effect coefficient of K3	V <sup>-1</sup>	0
KETA	Body-bias coefficient of bulk charge effect	V <sup>-1</sup>	-0.047
LA0	Length dependence of A0	m	0
LA1	Length dependence of A1	m/V	0
LA2	Length dependence of A2	m	0
LAGS	Length dependence of AGS	m/V	0
LALPHA0	Length dependence of ALPHA0	m <sup>2</sup> /V	0

Level=9 Parameter	Description	Units	Default
LALPHA1	Length dependence of ALPHA1	m/V	0
LB0	Length dependence of B0	m <sup>2</sup>	0
LB1	Length dependence of B1	m <sup>2</sup>	0
LBETA0	Length dependence of BETA0	Vm	0
LCDSC	Length dependence of CDSC	F/m	0
LCDSCEB	Length dependence of CDSCB	F/(Vm)	0
LCDSCECD	Length dependence of CDSCD	F/(Vm)	0
LCIT	Length dependence of CIT	F/m	0
LDELTA	Length dependence of DELTA	Vm	0
LDROUT	Length dependence of DROUT	m	0
LDSUB	Length dependence of DSUB	m	0
LDVT0	Length dependence of DVT0	m	0
LDVT0W	Length dependence of DVT0W	–	0
LDVT1	Length dependence of DVT1	m	0
LDVT1W	Length dependence of DVT1W	–	0
LDVT2	Length dependence of DVT2	m/V	0
LDVT2W	Length dependence of DVT2W	m/V	0
LDWB	Length dependence of DWB	m <sup>2</sup> /V <sup>1/2</sup>	0
LDWG	Length dependence of DWG	m <sup>2</sup> /V <sup>1/2</sup>	0
LETA0	Length dependence of ETA0	m	0
LETAB	Length dependence of ETAB	m/V	0
LINT	Length of offset fitting parameter from I-V without bias	m	0
LK1	Length dependence of K1	V <sup>1/2</sup> m	0
LK2	Length dependence of K2	m	0
LK3	Length dependence of K3	m	0
LK3B	Length dependence of K3B	m/V	0
LKETA	Length dependence of KETA	m/V	0
LNFACTOR	Length dependence of NFACTOR	m	0
LNGATE	Length dependence of NGATE	m/cm <sup>3</sup>	0

Level=9 Parameter	Description	Units	Default
LNLX	Length dependence of NLX	m <sup>2</sup>	0
LPCLM	Length dependence of PCLM	m	0
LPDIBLC1	Length dependence of PDIBLC1	m	0
LPDIBLC2	Length dependence of PDIBLC2	m	0
LPDIBLCB	Length dependence of PDIBLCB	m/V	0
LPRWB	Length dependence of PRWB	m/V <sup>1/2</sup>	0
LPRWG	Length dependence of PRWG	m/V	0
LPSCBE1	Length dependence of PSCBE1	V	0
LPSCBE2	Length dependence of PSCBE2	V	0
LPVAG	Length dependence of PVAG	m	0
LRDSW	Length dependence of RDSW	$\Omega - \mu\text{m-m}$	0
LUA	Length dependence of UA	m <sup>2</sup> /V	0
LUB	Length dependence of UB	m <sup>3</sup> /V <sup>2</sup>	0
LUC	Length dependence of UC	m <sup>2</sup> /V <sup>2</sup>	0
LVBM	Length dependence of VBM	Vm	0
LVFB	Length dependence of VFB	Vm	0
LVOFF	Length dependence of VOFF	Vm	0
LVSAT	Length dependence of VSAT	m <sup>2</sup> /s	0
LVTH0	Length dependence of VTH0	Vm	0
LW0	Length dependence of W0	m <sup>2</sup>	0
LWR	Length dependence of WR	m	0
NFACTOR	Subthreshold swing factor	–	1
NGATE	Poly gate doping concentration	cm <sup>-3</sup>	0
NLX	Lateral non-uniform doping parameter	m	1.74e-07
PA0	Cross-term dependence of A0	m <sup>2</sup>	0
PA1	Cross-term dependence of A1	m <sup>2</sup> /V	0
PA2	Cross-term dependence of A2	m <sup>2</sup>	0
PAGS	Cross-term dependence of AGS	m <sup>2</sup> /V	0

Level=9 Parameter	Description	Units	Default
PALPHA0	Cross-term dependence of ALPHA0	$m^3/V$	0
PALPHA1	Cross-term dependence of ALPHA1	$m^2/V$	0
PB0	Cross-term dependence of B0	$m^3$	0
PB1	Cross-term dependence of B1	$m^3$	0
PBETA0	Cross-term dependence of BETA0	$Vm^2$	0
PCDSC	Cross-term dependence of CDSC	F	0
PCDSCB	Cross-term dependence of CDSCB	F/V	0
PCDSCD	Cross-term dependence of CDSCD	F/V	0
PCIT	Cross-term dependence of CIT	F	0
PCLM	Channel length modulation parameter	–	1.3
PDELTA	Cross-term dependence of DELTA	$Vm^2$	0
PDIBLC1	First output resistance DIBL effect correction parameter	–	0.39
PDIBLC2	Second output resistance DIBL effect correction parameter	–	0.0086
PDIBLCB	Body effect coefficient of DIBL correction parameter	$V^{-1}$	0
PDR0UT	Cross-term dependence of DROUT	$m^2$	0
PDSUB	Cross-term dependence of DSUB	$m^2$	0
PDVT0	Cross-term dependence of DVT0	$m^2$	0
PDVT0W	Cross-term dependence of DVT0W	m	0
PDVT1	Cross-term dependence of DVT1	$m^2$	0
PDVT1W	Cross-term dependence of DVT1W	m	0
PDVT2	Cross-term dependence of DVT2	$m^2/V$	0
PDVT2W	Cross-term dependence of DVT2W	$m^2/V$	0
PDWB	Cross-term dependence of DWB	$m^3/V^{1/2}$	0
PDWG	Cross-term dependence of DWG	$m^3/V^{1/2}$	0
PETA0	Cross-term dependence of ETA0	$m^2$	0
PETAB	Cross-term dependence of ETAB	$m^2/V$	0
PK1	Cross-term dependence of K1	$V^{1/2}m^2$	0
PK2	Cross-term dependence of K2	$m^2$	0
PK3	Cross-term dependence of K3	$m^2$	0

Level=9 Parameter	Description	Units	Default
PK3B	Cross-term dependence of K3B	m <sup>2</sup> /V	0
PKETA	Cross-term dependence of KETA	m <sup>2</sup> /V	0
PNFACTOR	Cross-term dependence of NFACTOR	m <sup>2</sup>	0
PNGATE	Cross-term dependence of NGATE	m <sup>2</sup> /cm <sup>3</sup>	0
PNLX	Cross-term dependence of NLX	m <sup>3</sup>	0
PPCLM	Cross-term dependence of PCLM	m <sup>2</sup>	0
PPDIBLC1	Cross-term dependence of PDIBLC1	m <sup>2</sup>	0
PPDIBLC2	Cross-term dependence of PDIBLC2	m <sup>2</sup>	0
PPDIBLCB	Cross-term dependence of PDIBLCB	m <sup>2</sup> /V	0
PPRWB	Cross-term dependence of PRWB	m <sup>2</sup> /V <sup>1/2</sup>	0
PPRWG	Cross-term dependence of PRWG	m <sup>2</sup> /V	0
PPSCBE1	Cross-term dependence of PSCBE1	Vm	0
PPSCBE2	Cross-term dependence of PSCBE2	Vm	0
PPVAG	Cross-term dependence of PVAG	m <sup>2</sup>	0
PRDSW	Cross-term dependence of RDSW	$\Omega - \mu\text{m} - \text{m}^2$	0
PRWB	Body effect coefficient of RDSW	V <sup>-1/2</sup>	0
PRWG	Gate-bias effect coefficient of RDSW	V <sup>-1</sup>	0
PSCBE1	First substrate current body effect parameter	V/m	4.24e+08
PSCBE2	second substrate current body effect parameter	V/m	1e-05
PUA	Cross-term dependence of UA	m <sup>3</sup> /V	0
PUB	Cross-term dependence of UB	m <sup>4</sup> /V <sup>2</sup>	0
PUC	Cross-term dependence of UC	m <sup>3</sup> /V <sup>2</sup>	0
PVAG	Gate dependence of early voltage	-	0
PVBM	Cross-term dependence of VBM	Vm <sup>2</sup>	0
PVFB	Cross-term dependence of VFB	Vm <sup>2</sup>	0
PVOFF	Cross-term dependence of VOFF	Vm <sup>2</sup>	0
PVSAT	Cross-term dependence of VSAT	m <sup>3</sup> /s	0
PVTH0	Cross-term dependence of VTH0	Vm <sup>2</sup>	0
PW0	Cross-term dependence of W0	m <sup>3</sup>	0

Level=9 Parameter	Description	Units	Default
PWR	Cross-term dependence of WR	m <sup>2</sup>	0
RDSW	Parasitic resistance per unit width	$\Omega - \mu\text{m}$	0
UA	First-order mobility degradation coefficient	m/V	2.25e-09
UB	First-order mobility degradation coefficient	m <sup>2</sup> /V <sup>2</sup>	5.87e-19
UC	Body effect of mobility degradation coefficient	m/V <sup>2</sup>	-4.65e-11
VBM	Maximum applied body-bias in threshold voltage calculation	V	-3
VFB	Flat-band voltage	V	0
VOFF	Offset voltage in the subthreshold region at large W and L	V	-0.08
VSAT	Saturation velocity at temp = TNOM	m/s	80000
VTH0	Threshold voltage at Vbs = 0 for large L	V	0.7
W0	Narrow-width parameter	m	2.5e-06
WA0	Width dependence of A0	m	0
WA1	Width dependence of A1	m/V	0
WA2	Width dependence of A2	m	0
WAGS	Width dependence of AGS	m/V	0
WALPHA0	Width dependence of ALPHA0	m <sup>2</sup> /V	0
WALPHA1	Width dependence of ALPHA1	m/V	0
WB0	Width dependence of B0	m <sup>2</sup>	0
WB1	Width dependence of B1	m <sup>2</sup>	0
WBETA0	Width dependence of BETA0	Vm	0
WCDSC	Width dependence of CDSC	F/m	0
WCDSCB	Width dependence of CDSCB	F/(Vm)	0
WCDSCD	Width dependence of CDSCD	F/(Vm)	0
WCIT	Width dependence of CIT	F/m	0
WDELTA	Width dependence of DELTA	Vm	0
WDROUT	Width dependence of DROUT	m	0

Level=9 Parameter	Description	Units	Default
WDSUB	Width dependence of DSUB	m	0
WDVT0	Width dependence of DVT0	m	0
WDVT0W	Width dependence of DVT0W	–	0
WDVT1	Width dependence of DVT1	m	0
WDVT1W	Width dependence of DVT1W	–	0
WDVT2	Width dependence of DVT2	m/V	0
WDVT2W	Width dependence of DVT2W	m/V	0
WDWB	Width dependence of DWB	m <sup>2</sup> /V <sup>1/2</sup>	0
WDWG	Width dependence of DWG	m <sup>2</sup> /V <sup>1/2</sup>	0
WETA0	Width dependence of ETA0	m	0
WETAB	Width dependence of ETAB	m/V	0
WINT	Width-offset fitting parameter from I-V without bias	m	0
WK1	Width dependence of K1	V <sup>1/2</sup> m	0
WK2	Width dependence of K2	m	0
WK3	Width dependence of K3	m	0
WK3B	Width dependence of K3B	m/V	0
WKETA	Width dependence of KETA	m/V	0
WNFACTOR	Width dependence of NFACTOR	m	0
WNGATE	Width dependence of NGATE	m/cm <sup>3</sup>	0
WNLX	Width dependence of NLX	m <sup>2</sup>	0
WPCLM	Width dependence of PCLM	m	0
WPDIBLC1	Width dependence of PDIBLC1	m	0
WPDIBLC2	Width dependence of PDIBLC2	m	0
WPDIBLCB	Width dependence of PDIBLCB	m/V	0
WPRWB	Width dependence of PRWB	m/V <sup>1/2</sup>	0
WPRWG	Width dependence of PRWG	m/V	0
WPSCBE1	Width dependence of PSCBE1	V	0
WPSCBE2	Width dependence of PSCBE2	V	0
WPVAG	Width dependence of PVAG	m	0

Level=9 Parameter	Description	Units	Default
WR	Width offset from Weff for Rds Calculation	–	1
WRDSW	Width dependence of RDSW	$\Omega - \mu\text{m-m}$	0
WUA	Width dependence of UA	$\text{m}^2/\text{V}$	0
WUB	Width dependence of UB	$\text{m}^3/\text{V}^2$	0
WUC	Width dependence of UC	$\text{m}^2/\text{V}^2$	0
WVBM	Width dependence of VBM	Vm	0
WVFB	Width dependence of VFB	Vm	0
WVOFF	Width dependence of VOFF	Vm	0
WVSAT	Width dependence of VSAT	$\text{m}^2/\text{s}$	0
WVTHO	Width dependence of VTH0	Vm	0
WVO	Width dependence of W0	$\text{m}^2$	0
WWR	Width dependence of WR	m	0
<b><i>Doping Parameters</i></b>			
LNSUB	Length dependence of NSUB	$\text{m}/\text{cm}^3$	0
MJ	Bulk p-n bottom grading coefficient	–	0.5
MJSW	Bulk p-n sidewall grading coefficient	–	0.33
NSUB	Substrate doping density	$\text{cm}^{-3}$	6e+16
PNSUB	Cross-term dependence of NSUB	$\text{m}^2/\text{cm}^3$	0
WNSUB	Width dependence of NSUB	$\text{m}/\text{cm}^3$	0
<b><i>Flicker Parameters</i></b>			
AF	Flicker noise exponent	–	1
EF	Flicker exponent	–	1
EM	Saturation field	V/m	4.1e+07
KF	Flicker noise coefficient	–	0
NOIA	Noise parameter a	–	1e+20
NOIB	Noise parameter b	–	50000
NOIC	Noise parameter c	–	-1.4e-12
<b><i>Geometry Parameters</i></b>			
L	Default channel length	m	5e-06

Level=9 Parameter	Description	Units	Default
LL	Coefficient of length dependence for length offset	$m^{LLN}$	0
LLC	Coefficient of length dependence for CV channel length offset	$m^{LLN}$	0
LLN	Power of length dependence for length offset	–	0
LW	Coefficient of width dependence for length offset	$m^{LWN}$	0
LWC	Coefficient of width dependence for channel length offset	$m^{LWN}$	0
LWL	Coefficient of length and width cross term for length offset	$m^{LLN+LWN}$	0
LWLC	Coefficient of length and width dependence for CV channel length offset	$m^{LLN+LWN}$	0
LWN	Power of width dependence for length offset	–	0
LXJ	Length dependence of XJ	$m^2$	0
PXJ	Cross-term dependence of XJ	$m^3$	0
TOX	Gate oxide thickness	m	1.5e-08
W	Default channel width	m	5e-06
WL	Coefficient of length dependence for width offset	$m^{WLN}$	0
WLC	Coefficient of length dependence for CV channel width offset	$m^{WLN}$	0
WLN	Power of length dependence of width offset	–	0
WW	Coefficient of width dependence for width offset	$m^{WWN}$	0
WWC	Coefficient of width dependence for CV channel width offset	$m^{WWN}$	0
WWL	Coefficient of length and width cross term for width offset	$m^{WLN+WWN}$	0
WWLC	Coefficient of length and width dependence for CV channel width offset	$m^{WLN+WWN}$	0
WWN	Power of width dependence of width offset	–	0
WXJ	Width dependence of XJ	$m^2$	0
XJ	Junction depth	m	1.5e-07
<b><i>NQS Parameters</i></b>			
ELM	Elmore constant of the channel	–	5
LELM	Length dependence of ELM	m	0

Level=9 Parameter	Description	Units	Default
PELM	Cross-term dependence of ELM	m <sup>2</sup>	0
WELM	Width dependence of ELM	m	0
<b>Resistance Parameters</b>			
RSH	Drain, source diffusion sheet resistance	Ω	0
<b>Process Parameters</b>			
GAMMA1	Body effect coefficient near the surface	V <sup>1/2</sup>	0
GAMMA2	Body effect coefficient in the bulk	V <sup>1/2</sup>	0
JS	Bulk p-n saturation current density	A/m <sup>2</sup>	0.0001
LGAMMA1	Length dependence of GAMMA1	V <sup>1/2</sup> m	0
LGAMMA2	Length dependence of GAMMA2	V <sup>1/2</sup> m	0
LNCH	Length dependence of NCH	m/cm <sup>3</sup>	0
LU0	Length dependence of U0	m/(Vcm <sup>2</sup> s)	0
LVBX	Length dependence of VBX	Vm	0
LXT	Length dependence of XT	m <sup>2</sup>	0
NCH	Channel doping concentration	cm <sup>-3</sup>	1.7e+17
PGAMMA1	Cross-term dependence of GAMMA1	V <sup>1/2</sup> m <sup>2</sup>	0
PGAMMA2	Cross-term dependence of GAMMA2	V <sup>1/2</sup> m <sup>2</sup>	0
PNCH	Cross-term dependence of NCH	m <sup>2</sup> /cm <sup>3</sup>	0
PU0	Cross-term dependence of U0	m <sup>2</sup> /(Vcm <sup>2</sup> s)	0
PVBX	Cross-term dependence of VBX	Vm <sup>2</sup>	0
PXT	Cross-term dependence of XT	m <sup>3</sup>	0
TOXM	Gate oxide thickness used in extraction	m	1.5e-08
U0	Surface mobility	1/(Vcm <sup>2</sup> s)	0.067
VBX	Vbs at which the depletion region = XT	V	0
WGAMMA1	Width dependence of GAMMA1	V <sup>1/2</sup> m	0
WGAMMA2	Width dependence of GAMMA2	V <sup>1/2</sup> m	0
WNCH	Width dependence of NCH	m/cm <sup>3</sup>	0
WU0	Width dependence of U0	m/(Vcm <sup>2</sup> s)	0
WVBX	Width dependence of VBX	Vm	0
WXT	Width dependence of XT	m <sup>2</sup>	0

Level=9 Parameter	Description	Units	Default
XT	Doping depth	m	1.55e-07
<b>Temperature Parameters</b>			
AT	Temperature coefficient for saturation velocity	m/s	33000
KT1	Temperature coefficient for threshold voltage	V	-0.11
KT1L	Channel length dependence of the temperature coefficient for the threshold voltage	Vm	0
KT2	Body-bias coefficient fo the threshold voltage temperature effect	–	0.022
LAT	Length dependence of AT	m <sup>2</sup> /s	0
LKT1	Length dependence of KT1	Vm	0
LKT1L	Length dependence of KT1L	Vm <sup>2</sup>	0
LKT2	Length dependence of KT2	m	0
LPRT	Length dependence of PRT	$\Omega - \mu\text{m}$ -m	0
LUA1	Length dependence of UA1	m <sup>2</sup> /V	0
LUB1	Length dependence of UB1	m <sup>3</sup> /V <sup>2</sup>	0
LUC1	Length dependence of UC1	m <sup>2</sup> /( $^{\circ}\text{C}\text{V}^2$ )	0
LUTE	Length dependence of UTE	m	0
NJ	Emission coefficient of junction	–	1
PAT	Cross-term dependence of AT	m <sup>3</sup> /s	0
PKT1	Cross-term dependence of KT1	Vm <sup>2</sup>	0
PKT1L	Cross-term dependence of KT1L	Vm <sup>3</sup>	0
PKT2	Cross-term dependence of KT2	m <sup>2</sup>	0
PPRT	Cross-term dependence of PRT	$\Omega - \mu\text{m}$ -m <sup>2</sup>	0
PRT	Temerature coefficient for RDSW	$\Omega - \mu\text{m}$	0
PUA1	Cross-term dependence of UA1	m <sup>3</sup> /V	0
PUB1	Cross-term dependence of UB1	m <sup>4</sup> /V <sup>2</sup>	0
PUC1	Cross-term dependence of UC1	m <sup>3</sup> /( $^{\circ}\text{C}\text{V}^2$ )	0
PUTE	Cross-term dependence of UTE	m <sup>2</sup>	0

Level=9 Parameter	Description	Units	Default
TCJ	Temperature coefficient of Cj	°K <sup>-1</sup>	0
TCJSW	Temperature coefficient of Cswj	°K <sup>-1</sup>	0
TCJSWG	Temperature coefficient of Cjswg	°K <sup>-1</sup>	0
TNOM	Nominal device temperature	°C	27
TPB	Temperature coefficient of Pb	V/K	0
TPBSW	Temperature coefficient of Pbsw	V/K	0
TPBSWG	Temperature coefficient of Pbswg	V/K	0
UA1	Temperature coefficient for UA	m/V	4.31e-09
UB1	Temperature coefficient for UB	m <sup>2</sup> /V <sup>2</sup>	-7.61e-18
UC1	Temperature coefficient for UC	m/(°CV <sup>2</sup> )	-5.6e-11
UTE	Mobility temperature exponent	–	-1.5
WAT	Width dependence of AT	m <sup>2</sup> /s	0
WKT1	Width dependence of KT1	Vm	0
WKT1L	Width dependence of KT1L	Vm <sup>2</sup>	0
WKT2	Width dependence of KT2	m	0
WPRT	Width dependence of PRT	Ω – μm-m	0
WUA1	Width dependence of UA1	m <sup>2</sup> /V	0
WUB1	Width dependence of UB1	m <sup>3</sup> /V <sup>2</sup>	0
WUC1	Width dependence of UC1	m <sup>2</sup> /(°CV <sup>2</sup> )	0
WUTE	Width dependence of UTE	m	0
XTI	Junction current temperature exponent coefficient	–	3
<b><i>Voltage Parameters</i></b>			
PB	Bulk p-n bottom potential	V	1

Table 2.30: BSIM3 Device Model Parameters.

Level=10 Parameter	Description	Units	Default
DELTAVOX	The smoothing parameter in the Vox smoothing function	–	0.005
DTOXCV	Delta oxide thickness in meters in CapMod3	m	0
FNOIMOD	Flicker noise model selector	–	1
IGBMOD	Flicker noise model selector	–	0
IGCMOD	Gate-channel tunneling current model selector	–	0
KB1	Scaling factor for backgate charge	–	1
LKB1	Length dependence of KB1	m	0
LPOXEDGE	Length dependence of POXEDGE	m	0
NOIF	Floating body excess noise ideality factor	–	1
NTNOI	Thermal noise parameter	–	1
PKB1	Cross-term dependence of KB1	m <sup>2</sup>	0
POXEDGE	Factor for the gate edge Tox	–	1
PPOXEDGE	Cross-term dependence of POXEDGE	m <sup>2</sup>	0
RNOIA	Thermal noise coefficient	–	0.577
RNOIB	Thermal noise coefficient	–	0.37
RSHG	Gate sheet resistance	–	0.1
TNOIA	Thermal noise parameter	–	1.5
TNOIB	Thermal noise parameter	–	3.5
TNOIMOD	Thermal noise model selector	–	0
VBSOFD	Lower bound of built-in potential lowering for FD operation	V	0.5
VBSOPD	Upper bound of built-in potential lowering for FD operation	–	0
VOXH	The limit of Vox in gate current calculation	–	5
VTH0	Threshold voltage	–	0.7
WKB1	Width dependence of KB1	m	0
WPOXEDGE	Width dependence of POXEDGE	m	0
<b><i>Bin Parameters</i></b>			
LMAX	Maximum channel length	m	1
LMIN	Minimum channel length	m	0

Level=10 Parameter	Description	Units	Default
WMAX	Maximum channel width	m	1
WMIN	Minimum channel width	m	0
<b>Capacitance Parameters</b>			
ACDE	Exponential coefficient for charge thickness in capmod = 3 for accumulation and depletion regions	m/V	1
ASD	Source/Drain bottom diffusion smoothing parameter	–	0.3
CF	Firing field capacitance	F/m	8.16367e-11
CGDL	Light-doped drain-gate region overlap capacitance	F/m	0
CGDO	Non-LLD region drain-gate overlap capacitance per unit channel length	F/m	0
CGEO	Gate substrate overlap capacitance per unit channel length	F/m	0
CGSL	Light-doped source-gate region overlap capacitance	F/m	0
CGSO	Non-LLD region source-gate overlap capacitance per unit channel length	F/m	0
CJSWG	Source/Drain gate sidewall junction capacitance per unit width	F/m	1e-10
CKAPPA	Coefficient for lightly doped region overlap capacitance firing field capacitance	F/m	0.6
CLC	Constant term for short-channel model	m	1e-08
CLE	Exponential term for the short-channel model	–	0
CSDESW	Source/Drain sidewall fringing capacitance per unit length	F/m	0
CSDMIN	Source/Drain bottom diffusion minimum capacitance	V	0.000100544
DELVT	Threshold voltage adjust for C-V	V	0
DLBG	Length offset fitting parameter for backgate charge	m	0
DLC	Length offset fitting parameter from C-V	m	0
DLCB	Length offset fitting parameter for body charge	m	0
DWC	Width offset fitting parameter from C-V	m	0
FBODY	Scaling factor for body charge	–	1
LACDE	Length dependence of ACDE	m <sup>2</sup> /V	0

Level=10 Parameter	Description	Units	Default
LCGDL	Length dependence of CGDL	F	0
LCGSL	Length dependence of CGSL	F	0
LCKAPPA	Length dependence of CKAPPA	F	0
LDELVT	Length dependence of DELVT	Vm	0
LDIFO	Channel length dependency coefficient of diffusion capacitance	–	1
LMOIN	Length dependence of MOIN	m	0
LNDIF	Length dependence of NDIF	m	0
LNOFF	Length dependence of NOFF	m	0
LVSDFB	Length dependence of VSDFB	Vm	0
LVSDTH	Length dependence of VSDTH	Vm	0
MJSWG	Source/Drain gate sidewall junction capacitance grading coefficient	–	0.5
MOIN	Coefficient for the gate-bias dependent surface potential	–	15
NDIF	Power coefficient of channel length dependency for diffusion capacitance	–	-1
NOFF	CV parameter in Vgsteff, CV for weak to strong inversion	–	1
PACDE	Cross-term dependence of ACDE	m <sup>3</sup> /V	0
PBSWG	Source/drain gate sidewall junction built-in potential	V	0.7
PCGDL	Cross-term dependence of CGDL	Fm	0
PCGSL	Cross-term dependence of CGSL	Fm	0
PCKAPPA	Cross-term dependence of CKAPPA	Fm	0
PDELVT	Cross-term dependence of DELVT	Vm <sup>2</sup>	0
PMOIN	Cross-term dependence of MOIN	m <sup>2</sup>	0
PNDIF	Cross-term dependence of NDIF	m <sup>2</sup>	0
PNOFF	Cross-term dependence of NOFF	m <sup>2</sup>	0
PVSDFB	Cross-term dependence of VSDFB	Vm <sup>2</sup>	0
PVSDTH	Cross-term dependence of VSDTH	Vm <sup>2</sup>	0
TT	Diffusion capacitance transit time coefficient	s	1e-12
VSDFB	Source/Drain bottom diffusion capacitance flatband voltage	V	0

Level=10 Parameter	Description	Units	Default
VSDTH	Source/Drain bottom diffusion capacitance threshold voltage	V	0
WACDE	Width dependence of ACDE	m <sup>2</sup> /V	0
WCGDL	Width dependence of CGDL	F	0
WCGSL	Width dependence of CGSL	F	0
WCKAPPA	Width dependence of CKAPPA	F	0
WDELVT	Width dependence of DELVT	Vm	0
WMOIN	Width dependence of MOIN	m	0
WNDIF	Width dependence of NDIF	m	0
WNOFF	Width dependence of NOFF	m	0
WVSDFB	Width dependence of VSDFB	Vm	0
WVSDTH	Width dependence of VSDTH	Vm	0
XPART	Charge partitioning rate flag	–	0
<b>Control Parameters</b>			
BINUNIT	Binning unit selector	–	1
CAPMOD	Flag for capacitance models	–	2
MOBMOD	Mobility model selector	–	1
PARAMCHK	Parameter value check	–	0
SHMOD	Flag for self-heating, 0-no self-heating, 1-self-heating	–	0
TEMPMODEL	Specification to type of parameter interpolation over temperature (see User Guide section 5.3	–	NONE
VERSION	Version number	–	3.2
<b>Current Parameters</b>			
AIGC	Parameter for Igc	(F/g) <sup>1/2</sup> s/m	0.43
AIGSD	Parameter for Igs,d	(F/g) <sup>1/2</sup> s/m	0.43
BIGC	Parameter for Igc	(F/g) <sup>1/2</sup> s/m	0.054
BIGSD	Parameter for Igs,d	(F/g) <sup>1/2</sup> s/m	0.054
CIGC	Parameter for Igc	V <sup>-1</sup>	0.075
CIGSD	Parameter for Igs,d	V <sup>-1</sup>	0.075
DLCIG	Delta L for Ig model	V <sup>-1</sup>	0

Level=10 Parameter	Description	Units	Default
LAIGC	Length dependence of AIGC	$(F/g)^{1/2} \text{sm}/\text{mV}$	0
LAIGSD	Length dependence of AIGSD	$(F/g)^{1/2} \text{sm}/\text{mV}$	0
LBIGC	Length dependence of BIGC	$(F/g)^{1/2} \text{sm}/\text{mV}$	0
LBIGSD	Length dependence of BIGSD	$(F/g)^{1/2} \text{sm}/\text{mV}$	0
LCIGC	Length dependence of CIGC	m/V	0
LCIGSD	Length dependence of CIGSD	m/V	0
LNIGC	Length dependence of NIGC	m	0
LPIGCD	Length dependence of PIGCD	m	0
NIGC	Parameter for $I_{gc}$ slope	–	1
PAIGC	Cross-term dependence of AIGC	$(F/g)^{1/2} \text{sm}^2/\text{mV}$	0
PAIGSD	Cross-term dependence of AIGSD	$(F/g)^{1/2} \text{sm}^2/\text{mV}$	0
PBIGC	Cross-term dependence of BIGC	$(F/g)^{1/2} \text{sm}^2/\text{mV}$	0
PBIGSD	Cross-term dependence of BIGSD	$(F/g)^{1/2} \text{sm}^2/\text{mV}$	0
PCIGC	Cross-term dependence of CIGC	$\text{m}^2/\text{V}$	0
PCIGSD	Cross-term dependence of CIGSD	$\text{m}^2/\text{V}$	0
PIGCD	Parameter for $I_{gc}$ partition	–	1
PNIGC	Cross-term dependence of NIGC	$\text{m}^2$	0
PPIGCD	Cross-term dependence of PIGCD	$\text{m}^2$	0
WAIGC	Width dependence of AIGC	$(F/g)^{1/2} \text{sm}/\text{mV}$	0
WAIGSD	Width dependence of AIGSD	$(F/g)^{1/2} \text{sm}/\text{mV}$	0
WBIGC	Width dependence of BIGC	$(F/g)^{1/2} \text{sm}/\text{mV}$	0
WBIGSD	Width dependence of BIGSD	$(F/g)^{1/2} \text{sm}/\text{mV}$	0
WCIGC	Width dependence of CIGC	m/V	0
WCIGSD	Width dependence of CIGSD	m/V	0
WNIGC	Width dependence of NIGC	m	0
WPIGCD	Width dependence of PIGCD	m	0
<b>DC Parameters</b>			
A0	Bulk charge effect coefficient for channel length	–	1
A1	First non-saturation effect parameter	$\text{V}^{-1}$	0

Level=10 Parameter	Description	Units	Default
A2	Second non-saturation factor	–	1
AELY	Chananel length dependency of early voltage for bipolar current	V/m	0
AGIDL	GIDL constant	$\Omega^{-1}$	0
AGS	Gate-bias coefficient of abulk	$V^{-1}$	0
AHLI	High level injection parameter for bipolar current	–	0
ALPHA0	First parameter of impact-ionization current	m/V	0
B0	Bulk charge effect coefficient for channel width	m	0
B1	Bulk charge effect offset	m	0
BETA0	Second parameter of impact-ionization current	V	0
BETA1	Second Vds dependent parameter of impact ionization current	–	0
BETA2	Third Vds dependent parameter of impact ionization current	V	0.1
BGIDL	GIDL exponential coefficient	V/m	0
CDSC	Drain/source to channel coupling capacitance	F/m <sup>2</sup>	0.00024
CDSCB	Body-bias sensitivity of CDSC	F/(Vm <sup>2</sup> )	0
CDSCD	Drain-bias sensitivity of CDSC	F/(Vm <sup>2</sup> )	0
CIT	Interface trap capacitance	F/m <sup>2</sup>	0
DELTA	Effective Vds parameter	V	0.01
DROUT	L-dependence Coefficient of the DIBL correction parameter in Rout	–	0.56
DSUB	DIBL coefficient exponent in subthreshold region	–	0.56
DVTO	First coefficient of short-channel effect effect on threshold voltage	–	2.2
DVTOW	First coefficient of narrow-width effect effect on threshold voltage for small channel length	m <sup>-1</sup>	0
DVT1	Second coefficient of short-channel effect effect on threshold voltage	–	0.53
DVT1W	Second coefficient of narrow-width effect effect on threshold voltage for small channel length	m <sup>-1</sup>	5.3e+06

Level=10 Parameter	Description	Units	Default
DVT2	Body-bias coefficient of short-channel effect effect on threshold voltage	$V^{-1}$	-0.032
DVT2W	Body-bias coefficient of narrow-width effect effect on threshold voltage for small channel length	$V^{-1}$	-0.032
DWB	Coefficient of substrate body bias dependence of Weff	$m/V^{1/2}$	0
DWBC	Width offset for body contact isolation edge	m	0
DWG	Coefficient of gate dependence of Weff	$m/V^{1/2}$	0
ESATII	Saturation channel electric field for impact ionization current	V/m	1e+07
ETA0	DIBL coefficient in subthreshold region	–	0.08
ETAB	Body-bias coefficient for the subthreshold DIBL effect	$V^{-1}$	-0.07
FBJTII	Fraction of bipolar current affecting the impact ionization	–	0
ISBJT	BJT injection saturation current	$A/m^2$	1e-06
ISDIF	BOdy to source/drain injection saturation current	$A/m^2$	0
ISREC	Recombination in depletion saturation current	$A/m^2$	1e-05
ISTUN	Reverse tunneling saturation current	$A/m^2$	0
K1	First-order body effect coefficient	$V^{1/2}$	0.53
K1W1	First body effect width dependent parameter	m	0
K1W2	Second body effect width dependent parameter	m	0
K2	second-order body effect coefficient	–	-0.0186
K3	Narrow width coefficient	–	0
K3B	Body effect coefficient of K3	$V^{-1}$	0
KETA	Body-bias coefficient of bulk charge effect	$V^{-1}$	-0.6
KETAS	Surface potential adjustment for bulk charge effect	V	0
LA0	Length dependence of A0	m	0
LA1	Length dependence of A1	$m/V$	0
LA2	Length dependence of A2	m	0
LAELY	Length dependence of AELY	V	0
LAGIDL	Length dependence of AGIDL	$m/\Omega$	0
LAGS	Length dependence of AGS	$m/V$	0

Level=10 Parameter	Description	Units	Default
LAHLI	Length dependence of AHLI	m	0
LALPHA0	Length dependence of ALPHA0	m <sup>2</sup> /V	0
LB0	Length dependence of B0	m <sup>2</sup>	0
LB1	Length dependence of B1	m <sup>2</sup>	0
LBETA0	Length dependence of BETA0	Vm	0
LBETA1	Length dependence of BETA1	m	0
LBETA2	Length dependence of BETA2	Vm	0
LBGIDL	Length dependence of BGIDL	V	0
LBJT0	Reference channel length for bipolar current	m	2e-07
LCDSC	Length dependence of CDSC	F/m	0
LCDSCB	Length dependence of CDSCB	F/(Vm)	0
LCDSCD	Length dependence of CDSCD	F/(Vm)	0
LCIT	Length dependence of CIT	F/m	0
LDELTA	Length dependence of DELTA	Vm	0
LDROUT	Length dependence of DROUT	m	0
LDSUB	Length dependence of DSUB	m	0
LDVT0	Length dependence of DVT0	m	0
LDVT0W	Length dependence of DVT0W	–	0
LDVT1	Length dependence of DVT1	m	0
LDVT1W	Length dependence of DVT1W	–	0
LDVT2	Length dependence of DVT2	m/V	0
LDVT2W	Length dependence of DVT2W	m/V	0
LDWB	Length dependence of DWB	m <sup>2</sup> /V <sup>1/2</sup>	0
LDWG	Length dependence of DWG	m <sup>2</sup> /V <sup>1/2</sup>	0
LESATII	Length dependence of ESATII	V	0
LETA0	Length dependence of ETA0	m	0
LETAB	Length dependence of ETAB	m/V	0
LFBJTII	Length dependence of FBJTII	m	0
LII	Channel length dependent parameter at threshold for impact ionization current	–	0

Level=10 Parameter	Description	Units	Default
LINT	Length of offset fitting parameter from I-V without bias	m	0
LISBJT	Length dependence of ISBJT	A/m	0
LISDIF	Length dependence of ISDIF	A/m	0
LISREC	Length dependence of ISREC	A/m	0
LISTUN	Length dependence of ISTUN	A/m	0
LK1	Length dependence of K1	$V^{1/2}m$	0
LK1W1	Length dependence of K1W1	$m^2$	0
LK1W2	Length dependence of K1W2	$m^2$	0
LK2	Length dependence of K2	m	0
LK3	Length dependence of K3	m	0
LK3B	Length dependence of K3B	m/V	0
LKETA	Length dependence of KETA	m/V	0
LKETAS	Length dependence of KETAS	Vm	0
LLBJT0	Length dependence of LBJT0	$m^2$	0
LLII	Length dependence of LII	m	0
LN	Electron/hole diffusion length	m	2e-06
LNBJT	Length dependence of NBJT	m	0
LNDIODE	Length dependence of NDIODE	m	0
LNFACTOR	Length dependence of NFACTOR	m	0
LNGATE	Length dependence of NGATE	$m/cm^3$	0
LNGIDL	Length dependence of NGIDL	Vm	0
LNLX	Length dependence of NLX	$m^2$	0
LNRECF0	Length dependence of NRECF0	m	0
LNRECR0	Length dependence of NRECR0	m	0
LNTUN	Length dependence of NTUN	m	0
LPCLM	Length dependence of PCLM	m	0
LPDIBLC1	Length dependence of PDIBLC1	m	0
LPDIBLC2	Length dependence of PDIBLC2	m	0
LPDIBLCB	Length dependence of PDIBLCB	m/V	0

Level=10 Parameter	Description	Units	Default
LPRWB	Length dependence of PRWB	$m/V^{1/2}$	0
LPRWG	Length dependence of PRWG	$m/V$	0
LPVAG	Length dependence of PVAG	m	0
LRDSW	Length dependence of RDSW	$\Omega - \mu m - m$	0
LSII0	Length dependence of SII0	$m/V$	0
LSII1	Length dependence of SII1	$m/V$	0
LSII2	Length dependence of SII2	m	0
LSIID	Length dependence of SIID	$m/V$	0
LUA	Length dependence of UA	$m^2/V$	0
LUB	Length dependence of UB	$m^3/V^2$	0
LUC	Length dependence of UC	$m^2/V^2$	0
LVABJT	Length dependence of VABJT	Vm	0
LVDSATII0	Length dependence of VDSATII0	Vm	0
LVOFF	Length dependence of VOFF	Vm	0
LVRECO	Length dependence of VRECO	Vm	0
LVSAT	Length dependence of VSAT	$m^2/s$	0
LVTH0	Length dependence of VTH0	Vm	0
LVTUN0	Length dependence of VTUN0	Vm	0
LW0	Length dependence of W0	$m^2$	0
LWR	Length dependence of WR	m	0
NBJT	Power coefficient of channel length	–	1
NDIODE	Diode non-ideality factor	–	1
NFACTOR	Subthreshold swing factor	–	1
NGATE	Poly gate doping concentration	$cm^{-3}$	0
NGIDL	GIDL Vds enhancement coefficient	V	1.2
NLX	Lateral non-uniform doping parameter	m	1.74e-07
NRECFO	Recombination non-ideality factor at forward bias	–	2
NRECRO	Recombination non-ideality factor at reverse bias	–	10

Level=10 Parameter	Description	Units	Default
NTUN	Reverse tunneling non-ideality factor	–	10
PA0	Cross-term dependence of A0	m <sup>2</sup>	0
PA1	Cross-term dependence of A1	m <sup>2</sup> /V	0
PA2	Cross-term dependence of A2	m <sup>2</sup>	0
PAELY	Cross-term dependence of AELY	Vm	0
PAGIDL	Cross-term dependence of AGIDL	m <sup>2</sup> /Ω	0
PAGS	Cross-term dependence of AGS	m <sup>2</sup> /V	0
PAHLI	Cross-term dependence of AHLI	m <sup>2</sup>	0
PALPHA0	Cross-term dependence of ALPHA0	m <sup>3</sup> /V	0
PB0	Cross-term dependence of B0	m <sup>3</sup>	0
PB1	Cross-term dependence of B1	m <sup>3</sup>	0
PBETA0	Cross-term dependence of BETA0	Vm <sup>2</sup>	0
PBETA1	Cross-term dependence of BETA1	m <sup>2</sup>	0
PBETA2	Cross-term dependence of BETA2	Vm <sup>2</sup>	0
PBGIDL	Cross-term dependence of BGIDL	Vm	0
PCDSC	Cross-term dependence of CDSC	F	0
PCDSCB	Cross-term dependence of CDSCB	F/V	0
PCDSCD	Cross-term dependence of CDSCD	F/V	0
PCIT	Cross-term dependence of CIT	F	0
PCLM	Channel length modulation parameter	–	1.3
PDELTA	Cross-term dependence of DELTA	Vm <sup>2</sup>	0
PDIBLC1	First output resistance DIBL effect correction parameter	–	0.39
PDIBLC2	Second output resistance DIBL effect correction parameter	–	0.0086
PDIBLCB	Body effect coefficient of DIBL correction parameter	V <sup>-1</sup>	0
PDROUT	Cross-term dependence of DROUT	m <sup>2</sup>	0
PDSUB	Cross-term dependence of DSUB	m <sup>2</sup>	0
PDVT0	Cross-term dependence of DVT0	m <sup>2</sup>	0
PDVTOW	Cross-term dependence of DVTOW	m	0
PDVT1	Cross-term dependence of DVT1	m <sup>2</sup>	0

Level=10 Parameter	Description	Units	Default
PDVT1W	Cross-term dependence of DVT1W	m	0
PDVT2	Cross-term dependence of DVT2	m <sup>2</sup> /V	0
PDVT2W	Cross-term dependence of DVT2W	m <sup>2</sup> /V	0
PDWB	Cross-term dependence of DWB	m <sup>3</sup> /V <sup>1/2</sup>	0
PDWG	Cross-term dependence of DWG	m <sup>3</sup> /V <sup>1/2</sup>	0
PESATII	Cross-term dependence of ESATII	Vm	0
PETA0	Cross-term dependence of ETA0	m <sup>2</sup>	0
PETAB	Cross-term dependence of ETAB	m <sup>2</sup> /V	0
PFBJTII	Cross-term dependence of FBJTII	m <sup>2</sup>	0
PISBJT	Cross-term dependence of ISBJT	A	0
PISDIF	Cross-term dependence of ISDIF	A	0
PISREC	Cross-term dependence of ISREC	A	0
PISTUN	Cross-term dependence of ISTUN	A	0
PK1	Cross-term dependence of K1	V <sup>1/2</sup> m <sup>2</sup>	0
PK1W1	Cross-term dependence of K1W1	m <sup>3</sup>	0
PK1W2	Cross-term dependence of K1W2	m <sup>3</sup>	0
PK2	Cross-term dependence of K2	m <sup>2</sup>	0
PK3	Cross-term dependence of K3	m <sup>2</sup>	0
PK3B	Cross-term dependence of K3B	m <sup>2</sup> /V	0
PKETA	Cross-term dependence of KETA	m <sup>2</sup> /V	0
PKETAS	Cross-term dependence of KETAS	Vm <sup>2</sup>	0
PLBJT0	Cross-term dependence of LBJT0	m <sup>3</sup>	0
PLII	Cross-term dependence of LII	m <sup>2</sup>	0
PNBJT	Cross-term dependence of NBJT	m <sup>2</sup>	0
PNDIODE	Cross-term dependence of NDIODE	m <sup>2</sup>	0
PNFACTOR	Cross-term dependence of NFACTOR	m <sup>2</sup>	0
PNGATE	Cross-term dependence of NGATE	m <sup>2</sup> /cm <sup>3</sup>	0
PNGIDL	Cross-term dependence of NGIDL	Vm <sup>2</sup>	0
PNLX	Cross-term dependence of NLX	m <sup>3</sup>	0

Level=10 Parameter	Description	Units	Default
PNRECF0	Cross-term dependence of NRECF0	m <sup>2</sup>	0
PNRECR0	Cross-term dependence of NRECR0	m <sup>2</sup>	0
PNTUN	Cross-term dependence of NTUN	m <sup>2</sup>	0
PPCLM	Cross-term dependence of PCLM	m <sup>2</sup>	0
PPDIBLC1	Cross-term dependence of PDIBLC1	m <sup>2</sup>	0
PPDIBLC2	Cross-term dependence of PDIBLC2	m <sup>2</sup>	0
PPDIBLCB	Cross-term dependence of PDIBLCB	m <sup>2</sup> /V	0
PPRWB	Cross-term dependence of PRWB	m <sup>2</sup> /V <sup>1/2</sup>	0
PPRWG	Cross-term dependence of PRWG	m <sup>2</sup> /V	0
PPVAG	Cross-term dependence of PVAG	m <sup>2</sup>	0
PRDSW	Cross-term dependence of RDSW	$\Omega - \mu\text{m} - \text{m}^2$	0
PRWB	Body effect coefficient of RDSW	V <sup>-1/2</sup>	0
PRWG	Gate-bias effect coefficient of RDSW	V <sup>-1</sup>	0
PSII0	Cross-term dependence of SII0	m <sup>2</sup> /V	0
PSII1	Cross-term dependence of SII1	m <sup>2</sup> /V	0
PSII2	Cross-term dependence of SII2	m <sup>2</sup>	0
PSIID	Cross-term dependence of SIID	m <sup>2</sup> /V	0
PUA	Cross-term dependence of UA	m <sup>3</sup> /V	0
PUB	Cross-term dependence of UB	m <sup>4</sup> /V <sup>2</sup>	0
PUC	Cross-term dependence of UC	m <sup>3</sup> /V <sup>2</sup>	0
PVABJT	Cross-term dependence of VABJT	Vm <sup>2</sup>	0
PVAG	Gate dependence of early voltage	–	0
PVDSATII0	Cross-term dependence of VDSATII0	Vm <sup>2</sup>	0
PVOFF	Cross-term dependence of VOFF	Vm <sup>2</sup>	0
PVREC0	Cross-term dependence of VREC0	Vm <sup>2</sup>	0
PVSAT	Cross-term dependence of VSAT	m <sup>3</sup> /s	0
PVTH0	Cross-term dependence of VTH0	Vm <sup>2</sup>	0
PVTUN0	Cross-term dependence of VTUN0	Vm <sup>2</sup>	0
PW0	Cross-term dependence of W0	m <sup>3</sup>	0

Level=10 Parameter	Description	Units	Default
PWR	Cross-term dependence of WR	m <sup>2</sup>	0
RBODY	Intrinsic body contact sheet resistance	ohm/square	0
RBSH	Intrinsic body contact sheet resistance	ohm/square	0
RDSW	Parasitic resistance per unit width	$\Omega - \mu\text{m}$	100
RHALO	Body halo sheet resistance	ohm/m	1e+15
SII0	First Vgs dependent parameter of impact ionization current	V <sup>-1</sup>	0.5
SII1	Second Vgs dependent parameter of impact ionization current	V <sup>-1</sup>	0.1
SII2	Third Vgs dependent parameter of impact ionization current	-	0
SIID	Vds dependent parameter of drain saturation voltage for impact ionization current	V <sup>-1</sup>	0
TII	Temperature dependent parameter for impact ionization current	-	0
UA	First-order mobility degradation coefficient	m/V	2.25e-09
UB	First-order mobility degradation coefficient	m <sup>2</sup> /V <sup>2</sup>	5.87e-19
UC	Body effect of mobility degradation coefficient	m/V <sup>2</sup>	-4.65e-11
VABJT	Early voltage for bipolar current	V	10
VBM	Maximum applied body-bias in threshold voltage calculation	V	-3
VDSATII0	Normal drain saturation voltage at threshold for impact ionization current	V	0.9
VOFF	Offset voltage in the subthreshold region at large W and L	V	-0.08
VRECO	Voltage dependent parameter for recombination current	V	0
VSAT	Saturation velocity at temp = TNOM	m/s	80000
VTH0	Threshold voltage at Vbs = 0 for large L	V	0.7
VTUNO	Voltage dependent parameter for tunneling current	V	0
W0	Narrow-width parameter	m	2.5e-06

Level=10 Parameter	Description	Units	Default
WA0	Width dependence of A0	m	0
WA1	Width dependence of A1	m/V	0
WA2	Width dependence of A2	m	0
WAELY	Width dependence of AELY	V	0
WAGIDL	Width dependence of AGIDL	m/Ω	0
WAGS	Width dependence of AGS	m/V	0
WAHLI	Width dependence of AHLI	m	0
WALPHA0	Width dependence of ALPHA0	m <sup>2</sup> /V	0
WB0	Width dependence of B0	m <sup>2</sup>	0
WB1	Width dependence of B1	m <sup>2</sup>	0
WBETA0	Width dependence of BETA0	Vm	0
WBETA1	Width dependence of BETA1	m	0
WBETA2	Width dependence of BETA2	Vm	0
WBGIDL	Width dependence of BGIDL	V	0
WCDCS	Width dependence of CDSC	F/m	0
WCDCSB	Width dependence of CDSCB	F/(Vm)	0
WCDCSD	Width dependence of CDSCD	F/(Vm)	0
WCIT	Width dependence of CIT	F/m	0
WDELTA	Width dependence of DELTA	Vm	0
WDROUT	Width dependence of DROUT	m	0
WDSUB	Width dependence of DSUB	m	0
WDVT0	Width dependence of DVT0	m	0
WDVT0W	Width dependence of DVT0W	–	0
WDVT1	Width dependence of DVT1	m	0
WDVT1W	Width dependence of DVT1W	–	0
WDVT2	Width dependence of DVT2	m/V	0
WDVT2W	Width dependence of DVT2W	m/V	0
WDWB	Width dependence of DWB	m <sup>2</sup> /V <sup>1/2</sup>	0
WDWG	Width dependence of DWG	m <sup>2</sup> /V <sup>1/2</sup>	0

Level=10 Parameter	Description	Units	Default
WESATII	Width dependence of ESATII	V	0
WETAO	Width dependence of ETA0	m	0
WETAB	Width dependence of ETAB	m/V	0
WFBJTII	Width dependence of FBJTII	m	0
WINT	Width-offset fitting parameter from I-V without bias	m	0
WISBJT	Width dependence of ISBJT	A/m	0
WISDIF	Width dependence of ISDIF	A/m	0
WISREC	Width dependence of ISREC	A/m	0
WISTUN	Width dependence of ISTUN	A/m	0
WK1	Width dependence of K1	$V^{1/2}m$	0
WK1W1	Width dependence of K1W1	$m^2$	0
WK1W2	Width dependence of K1W2	$m^2$	0
WK2	Width dependence of K2	m	0
WK3	Width dependence of K3	m	0
WK3B	Width dependence of K3B	m/V	0
WKETA	Width dependence of KETA	m/V	0
WKETAS	Width dependence of KETAS	Vm	0
WLBJT0	Width dependence of LBJT0	$m^2$	0
WLII	Width dependence of LII	m	0
WNBJT	Width dependence of NBJT	m	0
WNDIODE	Width dependence of NDIODE	m	0
WNFACTOR	Width dependence of NFACTOR	m	0
WNGATE	Width dependence of NGATE	$m/cm^3$	0
WNGIDL	Width dependence of NGIDL	Vm	0
WNLX	Width dependence of NLX	$m^2$	0
WNRECF0	Width dependence of NRECF0	m	0
WNRECR0	Width dependence of NRECR0	m	0
WNTUN	Width dependence of NTUN	m	0
WPCLM	Width dependence of PCLM	m	0

Level=10 Parameter	Description	Units	Default
WPDIBLC1	Width dependence of PDIBLC1	m	0
WPDIBLC2	Width dependence of PDIBLC2	m	0
WPDIBLCB	Width dependence of PDIBLCB	m/V	0
WPRWB	Width dependence of PRWB	m/V <sup>1/2</sup>	0
WPRWG	Width dependence of PRWG	m/V	0
WPVAG	Width dependence of PVAG	m	0
WR	Width offset from Weff for Rds Calculation	–	1
WRDSW	Width dependence of RDSW	$\Omega - \mu\text{m} - \text{m}$	0
WSII0	Width dependence of SII0	m/V	0
WSII1	Width dependence of SII1	m/V	0
WSII2	Width dependence of SII2	m	0
WSIID	Width dependence of SIID	m/V	0
WUA	Width dependence of UA	m <sup>2</sup> /V	0
WUB	Width dependence of UB	m <sup>3</sup> /V <sup>2</sup>	0
WUC	Width dependence of UC	m <sup>2</sup> /V <sup>2</sup>	0
WVABJT	Width dependence of VABJT	Vm	0
WVDSATII0	Width dependence of VDSATII0	Vm	0
WVOFF	Width dependence of VOFF	Vm	0
WVRECO	Width dependence of VRECO	Vm	0
WVSAT	Width dependence of VSAT	m <sup>2</sup> /s	0
WVTH0	Width dependence of VTH0	Vm	0
WVTUN0	Width dependence of VTUN0	Vm	0
WVO	Width dependence of W0	m <sup>2</sup>	0
WWR	Width dependence of WR	m	0
<b>Doping Parameters</b>			
LNSUB	Length dependence of NSUB	m/cm <sup>3</sup>	0
NSUB	Substrate doping density	cm <sup>-3</sup>	6e+16
PNSUB	Cross-term dependence of NSUB	m <sup>2</sup> /cm <sup>3</sup>	0
WNSUB	Width dependence of NSUB	m/cm <sup>3</sup>	0

Level=10 Parameter	Description	Units	Default
<b><i>Flicker Parameters</i></b>			
AF	Flicker noise exponent	–	1
EF	Flicker exponent	–	1
EM	Saturation field	V/m	4.1e+07
KF	Flicker noise coefficient	–	0
NOIA	Noise parameter a	–	6.25e+41
NOIB	Noise parameter b	–	3.125e+26
NOIC	Noise parameter c	–	8.75e+09
<b><i>Geometry Parameters</i></b>			
L	Default channel length	m	5e-06
LL	Coefficient of length dependence for length offset	$m^{LLN}$	0
LLC	Coefficient of length dependence for CV channel length offset	$m^{LLN}$	0
LLN	Power of length dependence for length offset	–	1
LW	Coefficient of width dependence for length offset	$m^{LWN}$	0
LWC	Coefficient of width dependence for channel length offset	$m^{LWN}$	0
LWL	Coefficient of length and width cross term for length offset	$m^{LLN+LWN}$	0
LWLC	Coefficient of length and width dependence for CV channel length offset	$m^{LLN+LWN}$	0
LWN	Power of width dependence for length offset	–	1
LXJ	Length dependence of XJ	$m^2$	0
PXJ	Cross-term dependence of XJ	$m^3$	0
TOX	Gate oxide thickness	m	1e-08
W	Default channel width	m	5e-06
WL	Coefficient of length dependence for width offset	$m^{WLN}$	0
WLC	Coefficient of length dependence for CV channel width offset	$m^{WLN}$	0
WLN	Power of length dependence of width offset	–	1
WW	Coefficient of width dependence for width offset	$m^{WWN}$	0

Level=10 Parameter	Description	Units	Default
WWC	Coefficient of width dependence for CV channel width offset	$m^{WWN}$	0
WWL	Coefficient of length and width cross term for width offset	$m^{WLN+WWN}$	0
WWLC	Coefficient of length and width dependence for CV channel width offset	$m^{WLN+WWN}$	0
WWN	Power of width dependence of width offset	–	1
WXJ	Width dependence of XJ	$m^2$	0
XJ	Junction depth	m	1e-07
<b>Resistance Parameters</b>			
RSH	Drain, source diffusion sheet resistance	$\Omega$	0
<b>Process Parameters</b>			
GAMMA1	Body effect coefficient near the surface	$V^{1/2}$	0
GAMMA2	Body effect coefficient in the bulk	$V^{1/2}$	0
LNCH	Length dependence of NCH	$m/cm^3$	0
LU0	Length dependence of U0	$m/(Vcm^2s)$	0
NCH	Channel doping concentration	$cm^{-3}$	1.7e+17
PNCH	Cross-term dependence of NCH	$m^2/cm^3$	0
PU0	Cross-term dependence of U0	$m^2/(Vcm^2s)$	0
TBOX	Buried oxide thickness	m	3e-07
TOXM	Gate oxide thickness used in extraction	m	1e-08
TSI	Silicon film thickness	m	1e-07
U0	Surface mobility	$1/(Vcm^2s)$	0.067
VBX	Vbs at which the depletion region = XT	V	0
WNCH	Width dependence of NCH	$m/cm^3$	0
WU0	Width dependence of U0	$m/(Vcm^2s)$	0
XT	Doping depth	m	1.55e-07
<b>RF Parameters</b>			
LXRRCG1	Length dependence of XRRCG1	m	0
LXRRCG2	Length dependence of XRRCG2	m	0
NGCON	Number of gate contacts	–	1

Level=10 Parameter	Description	Units	Default
PXRCRG1	Cross-term dependence of XRCRG1	m <sup>2</sup>	0
PXRCRG2	Cross-term dependence of XRCRG2	m <sup>2</sup>	0
RGATEMOD	Gate resistance model selector	–	0
WXRCRG1	Width dependence of XRCRG1	m	0
WXRCRG2	Width dependence of XRCRG2	m	0
XGL	Offset of the gate length due to variations in patterning	m	0
XGW	Distance from the gate contact to the channel edge	m	0
XRCRG1	Parameter for distributed channel resistance effect for intrinsic input resistance	–	12
XRCRG2	Parameter to account for the excess channel diffusion resistance for intrinsic input resistance	–	1
<b>Temperature Parameters</b>			
AT	Temperature coefficient for saturation velocity	m/s	33000
CTHO	Thermal capacitance per unit width	F/m	1e-05
KT1	Temperature coefficient for threshold voltage	V	-0.11
KT1L	Channel length dependence of the temperature coefficient for the threshold voltage	Vm	0
KT2	Body-bias coefficient fo the threshold voltage temperature effect	–	0.022
LAT	Length dependence of AT	m <sup>2</sup> /s	0
LKT1	Length dependence of KT1	Vm	0
LKT1L	Length dependence of KT1L	Vm <sup>2</sup>	0
LKT2	Length dependence of KT2	m	0
LNTRECF	Length dependence of NTRECF	m	0
LNTRECR	Length dependence of NTRECR	m	0
LPRT	Length dependence of PRT	Ω – μm-m	0
LUA1	Length dependence of UA1	m <sup>2</sup> /V	0
LUB1	Length dependence of UB1	m <sup>3</sup> /V <sup>2</sup>	0
LUC1	Length dependence of UC1	m <sup>2</sup> /((°CV <sup>2</sup> ))	0
LUTE	Length dependence of UTE	m	0

Level=10 Parameter	Description	Units	Default
LXBJT	Length dependence of XBJT	m	0
LXDIF	Length dependence of XDIF	m	0
LXREC	Length dependence of XREC	m	0
LXTUN	Length dependence of XTUN	m	0
NTRECF	Temperature coefficient for NRECF	–	0
NTRECR	Temperature coefficient for NRECR	–	0
PAT	Cross-term dependence of AT	m <sup>3</sup> /s	0
PKT1	Cross-term dependence of KT1	Vm <sup>2</sup>	0
PKT1L	Cross-term dependence of KT1L	Vm <sup>3</sup>	0
PKT2	Cross-term dependence of KT2	m <sup>2</sup>	0
PNTRECF	Cross-term dependence of NTRECF	m <sup>2</sup>	0
PNTRECR	Cross-term dependence of NTRECR	m <sup>2</sup>	0
PPRT	Cross-term dependence of PRT	$\Omega - \mu\text{m} - \text{m}^2$	0
PRT	Temperature coefficient for RDSW	$\Omega - \mu\text{m}$	0
PUA1	Cross-term dependence of UA1	m <sup>3</sup> /V	0
PUB1	Cross-term dependence of UB1	m <sup>4</sup> /V <sup>2</sup>	0
PUC1	Cross-term dependence of UC1	m <sup>3</sup> /(°CV <sup>2</sup> )	0
PUTE	Cross-term dependence of UTE	m <sup>2</sup>	0
PXBJT	Cross-term dependence of XBJT	m <sup>2</sup>	0
PXDIF	Cross-term dependence of XDIF	m <sup>2</sup>	0
PXREC	Cross-term dependence of XREC	m <sup>2</sup>	0
PXTUN	Cross-term dependence of XTUN	m <sup>2</sup>	0
RTH0	Thermal resistance per unit width	$\Omega/\text{m}$	0
TCJSWG	Temperature coefficient of Cjswg	°K <sup>-1</sup>	0
TNOM	Nominal device temperature	°C	27
TPBSWG	Temperature coefficient of Pbswg	V/K	0
UA1	Temperature coefficient for UA	m/V	4.31e-09

Level=10 Parameter	Description	Units	Default
UB1	Temperature coefficient for UB	$m^2/V^2$	-7.61e-18
UC1	Temperature coefficient for UC	$m/(^{\circ}CV^2)$	-5.6e-11
UTE	Mobility temperature exponent	–	-1.5
WAT	Width dependence of AT	$m^2/s$	0
WKT1	Width dependence of KT1	$Vm$	0
WKT1L	Width dependence of KT1L	$Vm^2$	0
WKT2	Width dependence of KT2	$m$	0
WNTRECF	Width dependence of NTRECF	$m$	0
WNTRECR	Width dependence of NTRECR	$m$	0
WPRT	Width dependence of PRT	$\Omega - \mu m - m$	0
WTH0	Minimum width for thermal resistance calculation	$m$	0
WUA1	Width dependence of UA1	$m^2/V$	0
WUB1	Width dependence of UB1	$m^3/V^2$	0
WUC1	Width dependence of UC1	$m^2/(^{\circ}CV^2)$	0
WUTE	Width dependence of UTE	$m$	0
WXBJT	Width dependence of XBJT	$m$	0
WXDIF	Width dependence of XDIF	$m$	0
WXREC	Width dependence of XREC	$m$	0
WXTUN	Width dependence of XTUN	$m$	0
XBJT	Power dependence of JBJT on temperature	–	1
XDIF	Power dependence of JDIF on temperature	–	1
XREC	Power dependence of JREC on temperature	–	1
XTUN	Power dependence of JTUN on temperature	–	0
<b><i>Tunnelling Parameters</i></b>			
ALPHAGB1	First Vox dependent parameter for gate current in inversion	$V^{-1}$	0.35
ALPHAGB2	First Vox dependent parameter for gate current in accumulation	$V^{-1}$	0.43

Level=10 Parameter	Description	Units	Default
BETAGB1	Second Vox dependent parameter for gate current in inversion	$V^{-2}$	0.03
BETAGB2	First Vox dependent parameter for gate current in accumulation	$V^{-2}$	0.05
EBG	Effective bandgap in gate current calculation	V	1.2
IGMOD	Gate current model selector	–	0
LALPHAGB1	Length dependence of ALPHAGB1	m/V	0
LALPHAGB2	Length dependence of ALPHAGB2	m/V	0
LBETAGB1	Length dependence of BETAGB1	$m/V^2$	0
LBETAGB2	Length dependence of BETAGB2	$m/V^2$	0
NTOX	Power term of gate current	–	1
PALPHAGB1	Cross-term dependence of ALPHAGB1	$m^2/V$	0
PALPHAGB2	Cross-term dependence of ALPHAGB2	$m^2/V$	0
PBETAGB1	Cross-term dependence of BETAGB1	$m^2/V^2$	0
PBETAGB2	Cross-term dependence of BETAGB2	$m^2/V^2$	0
TOXQM	Oxide thickness for Igb calculation	m	1e-08
TOXREF	Target oxide thickness	m	2.5e-09
VECB	Vaux parameter for conduction band electron tunneling	–	0.026
VEVB	Vaux parameter for valence band electron tunneling	–	0.075
VGB1	Third Vox dependent parameter for gate current in inversion	V	300
VGB2	Third Vox dependent parameter for gate current in accumulation	V	17
WALPHAGB1	Width dependence of ALPHAGB1	m/V	0
WALPHAGB2	Width dependence of ALPHAGB2	m/V	0
WBETAGB1	Width dependence of BETAGB1	$m/V^2$	0
WBETAGB2	Width dependence of BETAGB2	$m/V^2$	0
DK2B	Third backgate body effect parameter for short channel effect	–	0
DVBD0	First short channel effect parameter in FD module	–	0
DVBD1	Second short channel effect parameter in FD module	–	0

Level=10 Parameter	Description	Units	Default
K1B	First backgate body effect parameter	–	1
K2B	Second backgate body effect parameter for short channel effect	–	0
MOINFD	Gate bias dependence coefficient of surface potential in FD module	–	1000
NOFFFD	Smoothing parameter in FD module	–	1
SOIMOD	SIO model selector, SOIMOD=0: BSIMPD, SOIMOD=1: undefined model for PD and FE, SOIMOD=2: ideal FD	–	0
VBASA	Offset voltage due to non-idealities	V	0
VOFFFD	Smoothing parameter in FD module	V	0

Table 2.31: BSIM3 SOI Device Model Parameters.

Model level 14 (BSIM4)

The level 14 MOSFET device in **Xyce** is based on the Berkeley BSIM4 model version 4.6.1. Its parameters are given in the following tables. Note that the table is not yet in its final form and parameters have not all been properly categorized with units in place. This will be corrected in the final SAND report version of the guide. Please see the BSIM4 web site for full documentation of these parameters.

Parameter	Description	Units	Default
AD	Drain area	–	0
AS	Source area	–	0
L	Length	–	5e-06
MIN	Minimize either D or S	–	0
NF	Number of fingers	–	1
NGCON	Number of gate contacts	–	1
OFF	Device is initially off	–	False
PD	Drain perimeter	–	0
PS	Source perimeter	–	0
RBDB	Body resistance	–	50
RBPB	Body resistance	–	50

Parameter	Description	Units	Default
RBPD	Body resistance	–	50
RBPS	Body resistance	–	50
RBSB	Body resistance	–	50
SA	distance between OD edge to poly of one side	–	0
SB	distance between OD edge to poly of the other side	–	0
SC	Distance to a single well edge	–	0
SCA	Integral of the first distribution function for scattered well dopant	–	0
SCB	Integral of the second distribution function for scattered well dopant	–	0
SCC	Integral of the third distribution function for scattered well dopant	–	0
SD	distance between neighbour fingers	–	0
W	Width	–	5e-06
XGW	Distance from gate contact center to device edge	–	0
<b>Basic Parameters</b>			
DELVTO	Zero bias threshold voltage variation	V	0
<b>Control Parameters</b>			
ACNQSMOD	AC NQS model selector	–	0
GEOMOD	Geometry dependent parasitics model selector	–	0
M	Multiplier for M devices connected in parallel	–	1
RBODYMOD	Distributed body R model selector	–	0
RGATEMOD	Gate resistance model selector	–	0
RGEOMOD	S/D resistance and contact model selector	–	0
TRNQSMOD	Transient NQS model selector	–	0
<b>Temperature Parameters</b>			
TEMP	Device temperature	°C	27
<b>Voltage Parameters</b>			
IC	Vector of initial values: Vds, Vgs, Vbs	V	0
<b>Asymmetric and Bias-Dependent <math>R_{ds}</math> Parameters</b>			
NRD	Number of squares in drain	–	1
NRS	Number of squares in source	–	1

Parameter	Description	Units	Default
-----------	-------------	-------	---------

Table 2.32: BSIM4 Device Instance Parameters.

Parameter	Description	Units	Default
AF	Flicker noise exponent	–	1
AIGSD	Parameter for I <sub>gs,d</sub>	–	0.0136
AT	Temperature coefficient of v <sub>sat</sub>	–	33000
BIGSD	Parameter for I <sub>gs,d</sub>	–	0.00171
BVD	Drain diode breakdown voltage	–	10
BVS	Source diode breakdown voltage	–	10
CIGSD	Parameter for I <sub>gs,d</sub>	–	0.075
CJD	Drain bottom junction capacitance per unit area	–	0.0005
CJS	Source bottom junction capacitance per unit area	–	0.0005
CJSWD	Drain sidewall junction capacitance per unit periphery	–	5e-10
CJSWGD	Drain (gate side) sidewall junction capacitance per unit width	–	5e-10
CJSWGS	Source (gate side) sidewall junction capacitance per unit width	–	5e-10
CJSWS	Source sidewall junction capacitance per unit periphery	–	5e-10
DLCIG	Delta L for I <sub>g</sub> model	–	0
DMCG	Distance of Mid-Contact to Gate edge	–	0
DMCGT	Distance of Mid-Contact to Gate edge in Test structures	–	0
DMCI	Distance of Mid-Contact to Isolation	–	0
DMDG	Distance of Mid-Diffusion to Gate edge	–	0
DWJ	Delta W for S/D junctions	–	0
EF	Flicker noise frequency exponent	–	1
EM	Flicker noise parameter	–	4.1e+07
EPSRGATE	Dielectric constant of gate relative to vacuum	–	11.7
GBMIN	Minimum body conductance	Ω <sup>-1</sup>	1e-12
IJTHDFWD	Forward drain diode forward limiting current	–	0.1
IJTHDREV	Reverse drain diode forward limiting current	–	0.1
IJTHSFWD	Forward source diode forward limiting current	–	0.1

Parameter	Description	Units	Default
IJTHSREV	Reverse source diode forward limiting current	–	0.1
JSD	Bottom drain junction reverse saturation current density	–	0.0001
JSS	Bottom source junction reverse saturation current density	–	0.0001
JSWD	Isolation edge sidewall drain junction reverse saturation current density	–	0
JSWGD	Gate edge drain junction reverse saturation current density	–	0
JSWGS	Gate edge source junction reverse saturation current density	–	0
JSWS	Isolation edge sidewall source junction reverse saturation current density	–	0
JTSD	Drain bottom trap-assisted saturation current density	–	0
JTSS	Source bottom trap-assisted saturation current density	–	0
JTSSWD	Drain STI sidewall trap-assisted saturation current density	–	0
JTSSWGD	Drain gate-edge sidewall trap-assisted saturation current density	–	0
JTSSWGS	Source gate-edge sidewall trap-assisted saturation current density	–	0
JTSSWS	Source STI sidewall trap-assisted saturation current density	–	0
K2WE	K2 shift factor for well proximity effect	–	0
K3B	Body effect coefficient of k3	–	0
KF	Flicker noise coefficient	–	0
KT1	Temperature coefficient of Vth	–	-0.11
KT1L	Temperature coefficient of Vth	–	0
KT2	Body-coefficient of kt1	–	0.022
KU0	Mobility degradation/enhancement coefficient for LOD	–	0
KU0WE	Mobility degradation factor for well proximity effect	–	0
KVSAT	Saturation velocity degradation/enhancement parameter for LOD	–	0
KVTHO	Threshold degradation/enhancement parameter for LOD	–	0

Parameter	Description	Units	Default
KVTHOWE	Threshold shift factor for well proximity effect	–	0
LA0	Length dependence of a0	–	0
LA1	Length dependence of a1	–	0
LA2	Length dependence of a2	–	0
LACDE	Length dependence of acde	–	0
LAGIDL	Length dependence of agidl	–	0
LAGISL	Length dependence of agisl	–	0
LAGS	Length dependence of ags	–	0
LAIGBACC	Length dependence of aigbacc	–	0
LAIGBINV	Length dependence of aigbinv	–	0
LAIGC	Length dependence of aigc	–	0
LAIGD	Length dependence of aigd	–	0
LAIGS	Length dependence of aigs	–	0
LAIGSD	Length dependence of aigsd	–	0
LALPHA0	Length dependence of alpha0	–	0
LALPHA1	Length dependence of alpha1	–	0
LAT	Length dependence of at	–	0
LB0	Length dependence of b0	–	0
LB1	Length dependence of b1	–	0
LBETA0	Length dependence of beta0	–	0
LBGIDL	Length dependence of bgidl	–	0
LBGISL	Length dependence of bgisl	–	0
LBIGBACC	Length dependence of bigbacc	–	0
LBIGBINV	Length dependence of bigbinv	–	0
LBIGC	Length dependence of bigc	–	0
LBIGD	Length dependence of bigd	–	0
LBIGS	Length dependence of bigs	–	0
LBIGSD	Length dependence of bigsd	–	0
LCDSC	Length dependence of cdsc	–	0
LCDSCB	Length dependence of cdsb	–	0

Parameter	Description	Units	Default
LCDSCD	Length dependence of cdsd	–	0
LCF	Length dependence of cf	–	0
LCGDL	Length dependence of cgdl	–	0
LCGIDL	Length dependence of cgidl	–	0
LCGISL	Length dependence of cgisl	–	0
LCGSL	Length dependence of cgsl	–	0
LCIGBACC	Length dependence of cigbacc	–	0
LCIGBINV	Length dependence of cigbinv	–	0
LCIGC	Length dependence of cigc	–	0
LCIGD	Length dependence of cigd	–	0
LCIGS	Length dependence of cigs	–	0
LCIGSD	Length dependence of cigsd	–	0
LCIT	Length dependence of cit	–	0
LCKAPPAD	Length dependence of ckappad	–	0
LCKAPPAS	Length dependence of ckappas	–	0
LCLC	Length dependence of clc	–	0
LCLE	Length dependence of cle	–	0
LDELTA	Length dependence of delta	–	0
LDROUT	Length dependence of drout	–	0
LDSUB	Length dependence of dsub	–	0
LDVT0	Length dependence of dvt0	–	0
LDVT0W	Length dependence of dvt0w	–	0
LDVT1	Length dependence of dvt1	–	0
LDVT1W	Length dependence of dvt1w	–	0
LDVT2	Length dependence of dvt2	–	0
LDVT2W	Length dependence of dvt2w	–	0
LDVTP0	Length dependence of dvtp0	–	0
LDVTP1	Length dependence of dvtp1	–	0
LDWB	Length dependence of dwb	–	0
LDWG	Length dependence of dwg	–	0

Parameter	Description	Units	Default
LEGIDL	Length dependence of egidl	–	0
LEGISL	Length dependence of egisl	–	0
LEIGBINV	Length dependence for eigbinv	–	0
LETAO	Length dependence of eta0	–	0
LETAB	Length dependence of etab	–	0
LEU	Length dependence of eu	–	0
LFPROUT	Length dependence of pdiblcb	–	0
LGAMMA1	Length dependence of gamma1	–	0
LGAMMA2	Length dependence of gamma2	–	0
LINTNOI	lint offset for noise calculation	–	0
LK1	Length dependence of k1	–	0
LK2	Length dependence of k2	–	0
LK2WE	Length dependence of k2we	–	0
LK3	Length dependence of k3	–	0
LK3B	Length dependence of k3b	–	0
LKETA	Length dependence of keta	–	0
LKT1	Length dependence of kt1	–	0
LKT1L	Length dependence of kt1l	–	0
LKT2	Length dependence of kt2	–	0
LKU0	Length dependence of ku0	–	0
LKU0WE	Length dependence of ku0we	–	0
LKVTH0	Length dependence of kvth0	–	0
LKVTH0WE	Length dependence of kvth0we	–	0
LL	Length reduction parameter	–	0
LLAMBDA	Length dependence of lambda	–	0
LLC	Length reduction parameter for CV	–	0
LLN	Length reduction parameter	–	1
LLODKU0	Length parameter for u0 LOD effect	–	0
LLODVTH	Length parameter for vth LOD effect	–	0
LLP	Length dependence of lp	–	0

Parameter	Description	Units	Default
LLPEO	Length dependence of lpe0	–	0
LLPEB	Length dependence of lpeb	–	0
LMAX	Maximum length for the model	–	1
LMIN	Minimum length for the model	–	0
LMINV	Length dependence of minv	–	0
LMINVCV	Length dependence of minvcv	–	0
LMOIN	Length dependence of moin	–	0
LNDEP	Length dependence of ndep	–	0
LNFACTOR	Length dependence of nfactor	–	0
LNGATE	Length dependence of ngate	–	0
LNIGBACC	Length dependence of nighbacc	–	0
LNIGBINV	Length dependence of nighbinv	–	0
LNIGC	Length dependence of nigc	–	0
LNOFF	Length dependence of noff	–	0
LNSD	Length dependence of nsd	–	0
LNSUB	Length dependence of nsub	–	0
LNTOX	Length dependence of ntox	–	0
LODETA0	eta0 shift modification factor for stress effect	–	1
LODK2	K2 shift modification factor for stress effect	–	1
LPCLM	Length dependence of pclm	–	0
LPDIBLC1	Length dependence of pdiblc1	–	0
LPDIBLC2	Length dependence of pdiblc2	–	0
LPDIBLCB	Length dependence of pdiblcb	–	0
LPDITS	Length dependence of pdits	–	0
LPDITSD	Length dependence of pditsd	–	0
LPHIN	Length dependence of phin	–	0
LPIGCD	Length dependence for pigcd	–	0
LPOXEDGE	Length dependence for poxedge	–	0
LPRT	Length dependence of prt	–	0
LPRWB	Length dependence of prwb	–	0

Parameter	Description	Units	Default
LPRWG	Length dependence of prwg	–	0
LPSCBE1	Length dependence of pscbe1	–	0
LPSCBE2	Length dependence of pscbe2	–	0
LPVAG	Length dependence of pvag	–	0
LRDSW	Length dependence of rdsw	–	0
LRDW	Length dependence of rdw	–	0
LRSW	Length dependence of rsw	–	0
LTVFBSDOFF	Length dependence of tvfbsdoff	–	0
LTVOFF	Length dependence of tvoff	–	0
LU0	Length dependence of u0	–	0
LUA	Length dependence of ua	–	0
LUA1	Length dependence of ua1	–	0
LUB	Length dependence of ub	–	0
LUB1	Length dependence of ub1	–	0
LUC	Length dependence of uc	–	0
LUC1	Length dependence of uc1	–	0
LUD	Length dependence of ud	–	0
LUD1	Length dependence of ud1	–	0
LUP	Length dependence of up	–	0
LUTE	Length dependence of ute	–	0
LVBM	Length dependence of vbm	–	0
LVBX	Length dependence of vbx	–	0
LVFB	Length dependence of vfb	–	0
LVFBCV	Length dependence of vfbcv	–	0
LVFBSDOFF	Length dependence of vfbsdoff	–	0
LVOFF	Length dependence of voff	–	0
LVOFFCV	Length dependence of voffcv	–	0
LVSAT	Length dependence of vsat	–	0
LVTHO		–	0
LVTL	Length dependence of vtl	–	0

Parameter	Description	Units	Default
LW	Length reduction parameter	–	0
LW0	Length dependence of w0	–	0
LWC	Length reduction parameter for CV	–	0
LWL	Length reduction parameter	–	0
LWLC	Length reduction parameter for CV	–	0
LWN	Length reduction parameter	–	1
LWR	Length dependence of wr	–	0
LXJ	Length dependence of xj	–	0
LXN	Length dependence of xn	–	0
LXRCRG1	Length dependence of xrcrg1	–	0
LXRCRG2	Length dependence of xrcrg2	–	0
LXT	Length dependence of xt	–	0
MJD	Drain bottom junction capacitance grading coefficient	–	0.5
MJS	Source bottom junction capacitance grading coefficient	–	0.5
MJSWD	Drain sidewall junction capacitance grading coefficient	–	0.33
MJSWGD	Drain (gate side) sidewall junction capacitance grading coefficient	–	0.33
MJSWGS	Source (gate side) sidewall junction capacitance grading coefficient	–	0.33
MJSWS	Source sidewall junction capacitance grading coefficient	–	0.33
NGCON	Number of gate contacts	–	1
NJD	Drain junction emission coefficient	–	1
NJS	Source junction emission coefficient	–	1
NJTS	Non-ideality factor for bottom junction	–	20
NJTSD	Non-ideality factor for bottom junction drain side	–	20
NJTSSW	Non-ideality factor for STI sidewall junction	–	20
NJTSSWD	Non-ideality factor for STI sidewall junction drain side	–	20
NJTSSWG	Non-ideality factor for gate-edge sidewall junction	–	20
NJTSSWGD	Non-ideality factor for gate-edge sidewall junction drain side	–	20
NTNOI	Thermal noise parameter	–	1

Parameter	Description	Units	Default
PA0	Cross-term dependence of a0	–	0
PA1	Cross-term dependence of a1	–	0
PA2	Cross-term dependence of a2	–	0
PACDE	Cross-term dependence of acde	–	0
PAGIDL	Cross-term dependence of agidl	–	0
PAGISL	Cross-term dependence of agisl	–	0
PAGS	Cross-term dependence of ags	–	0
PAIGBACC	Cross-term dependence of aigbacc	–	0
PAIGBINV	Cross-term dependence of aigbinv	–	0
PAIGC	Cross-term dependence of aigc	–	0
PAIGD	Cross-term dependence of aigd	–	0
PAIGS	Cross-term dependence of aigs	–	0
PAIGSD	Cross-term dependence of aigsd	–	0
PALPHA0	Cross-term dependence of alpha0	–	0
PALPHA1	Cross-term dependence of alpha1	–	0
PAT	Cross-term dependence of at	–	0
PB0	Cross-term dependence of b0	–	0
PB1	Cross-term dependence of b1	–	0
PBD	Drain junction built-in potential	–	1
PBETA0	Cross-term dependence of beta0	–	0
PBGIDL	Cross-term dependence of bgidl	–	0
PBGISL	Cross-term dependence of bgisl	–	0
PBIGBACC	Cross-term dependence of bigbacc	–	0
PBIGBINV	Cross-term dependence of bigbinv	–	0
PBIGC	Cross-term dependence of bigc	–	0
PBIGD	Cross-term dependence of bigd	–	0
PBIGS	Cross-term dependence of bigs	–	0
PBIGSD	Cross-term dependence of bigsd	–	0
PBS	Source junction built-in potential	–	1
PBSWD	Drain sidewall junction capacitance built in potential	–	1

Parameter	Description	Units	Default
PBSWGD	Drain (gate side) sidewall junction capacitance built in potential	–	1
PBSWGS	Source (gate side) sidewall junction capacitance built in potential	–	1
PBSWS	Source sidewall junction capacitance built in potential	–	1
PCDSC	Cross-term dependence of cdsc	–	0
PCDSCB	Cross-term dependence of cdsbc	–	0
PCDSCD	Cross-term dependence of cdsdc	–	0
PCF	Cross-term dependence of cf	–	0
PCGDL	Cross-term dependence of cgdl	–	0
PCGIDL	Cross-term dependence of cgidl	–	0
PCGISL	Cross-term dependence of cgisl	–	0
PCGSL	Cross-term dependence of cgsl	–	0
PCIGBACC	Cross-term dependence of cigbacc	–	0
PCIGBINV	Cross-term dependence of cigbinv	–	0
PCIGC	Cross-term dependence of cigc	–	0
PCIGD	Cross-term dependence of cigd	–	0
PCIGS	Cross-term dependence of cigs	–	0
PCIGSD	Cross-term dependence of cigsd	–	0
PCIT	Cross-term dependence of cit	–	0
PCKAPPAD	Cross-term dependence of ckappad	–	0
PCKAPPAS	Cross-term dependence of ckappas	–	0
PCLC	Cross-term dependence of clc	–	0
PCLE	Cross-term dependence of cle	–	0
PDELTA	Cross-term dependence of delta	–	0
PDROUT	Cross-term dependence of drout	–	0
PDSUB	Cross-term dependence of dsub	–	0
PDVT0	Cross-term dependence of dvt0	–	0
PDVT0w	Cross-term dependence of dvt0w	–	0
PDVT1	Cross-term dependence of dvt1	–	0
PDVT1w	Cross-term dependence of dvt1w	–	0

Parameter	Description	Units	Default
PDVT2	Cross-term dependence of dvt2	–	0
PDVT2W	Cross-term dependence of dvt2w	–	0
PDVTP0	Cross-term dependence of dvtp0	–	0
PDVTP1	Cross-term dependence of dvtp1	–	0
PDWB	Cross-term dependence of dwb	–	0
PDWG	Cross-term dependence of dwg	–	0
PEGIDL	Cross-term dependence of egidl	–	0
PEGISL	Cross-term dependence of egisl	–	0
PEIGBINV	Cross-term dependence for eigbinv	–	0
PETA0	Cross-term dependence of eta0	–	0
PETAB	Cross-term dependence of etab	–	0
PEU	Cross-term dependence of eu	–	0
PFPROUT	Cross-term dependence of pdiblcb	–	0
PGAMMA1	Cross-term dependence of gamma1	–	0
PGAMMA2	Cross-term dependence of gamma2	–	0
PHIG	Work Function of gate	–	4.05
PK1	Cross-term dependence of k1	–	0
PK2	Cross-term dependence of k2	–	0
PK2WE	Cross-term dependence of k2we	–	0
PK3	Cross-term dependence of k3	–	0
PK3B	Cross-term dependence of k3b	–	0
PKETA	Cross-term dependence of keta	–	0
PKT1	Cross-term dependence of kt1	–	0
PKT1L	Cross-term dependence of kt1l	–	0
PKT2	Cross-term dependence of kt2	–	0
PKU0	Cross-term dependence of ku0	–	0
PKUOWE	Cross-term dependence of ku0we	–	0
PKVTH0	Cross-term dependence of kvth0	–	0
PKVTHOWE	Cross-term dependence of kvth0we	–	0
PLAMBDA	Cross-term dependence of lambda	–	0

Parameter	Description	Units	Default
PLP	Cross-term dependence of lp	–	0
PLPEO	Cross-term dependence of lpe0	–	0
PLPEB	Cross-term dependence of lpeb	–	0
PMINV	Cross-term dependence of minv	–	0
PMINVCV	Cross-term dependence of minvcv	–	0
PMOIN	Cross-term dependence of moin	–	0
PNDEP	Cross-term dependence of ndep	–	0
PNFACTOR	Cross-term dependence of nfactor	–	0
PNGATE	Cross-term dependence of ngate	–	0
PNIGBACC	Cross-term dependence of nigbacc	–	0
PNIGBINV	Cross-term dependence of nigbinv	–	0
PNIGC	Cross-term dependence of nigc	–	0
PNOFF	Cross-term dependence of noff	–	0
PNSD	Cross-term dependence of nsd	–	0
PNSUB	Cross-term dependence of nsub	–	0
PNTOX	Cross-term dependence of ntox	–	0
PPCLM	Cross-term dependence of pclm	–	0
PPDIBLC1	Cross-term dependence of pdiblc1	–	0
PPDIBLC2	Cross-term dependence of pdiblc2	–	0
PPDIBLCB	Cross-term dependence of pdiblcb	–	0
PPDITS	Cross-term dependence of pdits	–	0
PPDITSD	Cross-term dependence of pditsd	–	0
PPHIN	Cross-term dependence of phin	–	0
PPIGCD	Cross-term dependence for pigcd	–	0
PPOXEDGE	Cross-term dependence for poxedge	–	0
PPRT	Cross-term dependence of prt	–	0
PPRWB	Cross-term dependence of prwb	–	0
PPRWG	Cross-term dependence of prwg	–	0
PPSCBE1	Cross-term dependence of psbbe1	–	0
PPSCBE2	Cross-term dependence of psbbe2	–	0

Parameter	Description	Units	Default
PPVAG	Cross-term dependence of pvag	–	0
PRDSW	Cross-term dependence of rdsw	–	0
PRDW	Cross-term dependence of rdw	–	0
PRSW	Cross-term dependence of rsw	–	0
PRT	Temperature coefficient of parasitic resistance	–	0
PTVFBSDOFF	Cross-term dependence of tvfbsdoff	–	0
PTVOFF	Cross-term dependence of tvoff	–	0
PU0	Cross-term dependence of u0	–	0
PUA	Cross-term dependence of ua	–	0
PUA1	Cross-term dependence of ua1	–	0
PUB	Cross-term dependence of ub	–	0
PUB1	Cross-term dependence of ub1	–	0
PUC	Cross-term dependence of uc	–	0
PUC1	Cross-term dependence of uc1	–	0
PUD	Cross-term dependence of ud	–	0
PUD1	Cross-term dependence of ud1	–	0
PUP	Cross-term dependence of up	–	0
PUTE	Cross-term dependence of ute	–	0
PVAG	Gate dependence of output resistance parameter	–	0
PVBM	Cross-term dependence of vbm	–	0
PVBX	Cross-term dependence of vbx	–	0
PVFB	Cross-term dependence of vfb	–	0
PVFBCV	Cross-term dependence of vfbcv	–	0
PVFBSDOFF	Cross-term dependence of vfbsdoff	–	0
PVOFF	Cross-term dependence of voff	–	0
PVOFFCV	Cross-term dependence of voffcv	–	0
PVSAT	Cross-term dependence of vsat	–	0
PVTH0		–	0
PVTL	Cross-term dependence of vtl	–	0
PW0	Cross-term dependence of w0	–	0

Parameter	Description	Units	Default
PWR	Cross-term dependence of wr	–	0
PXJ	Cross-term dependence of xj	–	0
PXN	Cross-term dependence of xn	–	0
PXRCRG1	Cross-term dependence of xrcrg1	–	0
PXRCRG2	Cross-term dependence of xrcrg2	–	0
PXT	Cross-term dependence of xt	–	0
RBDB	Resistance between bNode and dbNode	$\Omega$	50
RDBBX0	Body resistance RBDBX scaling	–	100
RDBBY0	Body resistance RDBBY scaling	–	100
RBPB	Resistance between bNodePrime and bNode	$\Omega$	50
RBPBX0	Body resistance RBPBX scaling	–	100
RBPBXL	Body resistance RBPBX L scaling	–	0
RBPBXNF	Body resistance RBPBX NF scaling	–	0
RBPBXW	Body resistance RBPBX W scaling	–	0
RBPBY0	Body resistance RBPBY scaling	–	100
RBPBYL	Body resistance RBPBY L scaling	–	0
RBPBYNF	Body resistance RBPBY NF scaling	–	0
RBPBYW	Body resistance RBPBY W scaling	–	0
RBPD	Resistance between bNodePrime and bNode	$\Omega$	50
RBPDO	Body resistance RBPDO scaling	–	50
RBPDL	Body resistance RBPDO L scaling	–	0
RBPDNF	Body resistance RBPDO NF scaling	–	0
RBPDW	Body resistance RBPDO W scaling	–	0
RBPS	Resistance between bNodePrime and sbNode	$\Omega$	50
RBPS0	Body resistance RBPS scaling	–	50
RBPSL	Body resistance RBPS L scaling	–	0
RBPSNF	Body resistance RBPS NF scaling	–	0
RBPSW	Body resistance RBPS W scaling	–	0
RBSB	Resistance between bNode and sbNode	$\Omega$	50
RBSBX0	Body resistance RBSBX scaling	–	100

Parameter	Description	Units	Default
RBSBY0	Body resistance RBSBY scaling	–	100
RBSDBXL	Body resistance RBSDBX L scaling	–	0
RBSDBXNF	Body resistance RBSDBX NF scaling	–	0
RBSDBXW	Body resistance RBSDBX W scaling	–	0
RBSDBYL	Body resistance RBSDBY L scaling	–	0
RBSDBYNF	Body resistance RBSDBY NF scaling	–	0
RBSDBYW	Body resistance RBSDBY W scaling	–	0
RNOIA	Thermal noise coefficient	–	0.577
RNOIB	Thermal noise coefficient	–	0.5164
SAREF	Reference distance between OD edge to poly of one side	–	1e-06
SBREF	Reference distance between OD edge to poly of the other side	–	1e-06
SCREF	Reference distance to calculate SCA, SCB and SCC	–	1e-06
STETA0	eta0 shift factor related to stress effect on vth	–	0
STK2	K2 shift factor related to stress effect on vth	–	0
TCJ	Temperature coefficient of cj	–	0
TCJSW	Temperature coefficient of cjsw	–	0
TCJSWG	Temperature coefficient of cjswg	–	0
TKU0	Temperature coefficient of KU0	–	0
TNJTS	Temperature coefficient for NJTS	–	0
TNJTSD	Temperature coefficient for NJTSD	–	0
TNJTSSW	Temperature coefficient for NJTSSW	–	0
TNJTSSWD	Temperature coefficient for NJTSSWD	–	0
TNJTSSWG	Temperature coefficient for NJTSSWG	–	0
TNJTSSWGD	Temperature coefficient for NJTSSWGD	–	0
TNOIA	Thermal noise parameter	–	1.5
TNOIB	Thermal noise parameter	–	3.5
TNOM	Parameter measurement temperature	–	27
TPB	Temperature coefficient of pb	–	0
TPBSW	Temperature coefficient of pbsw	–	0

Parameter	Description	Units	Default
TPBSWG	Temperature coefficient of pbswg	–	0
TVFBSDOFF	Temperature parameter for vfbsdoff	–	0
TVOFF	Temperature parameter for voff	–	0
UA1	Temperature coefficient of ua	–	1e-09
UB1	Temperature coefficient of ub	–	-1e-18
UC1	Temperature coefficient of uc	–	-5.6e-11
UD1	Temperature coefficient of ud	–	0
UTE	Temperature coefficient of mobility	–	-1.5
VTSD	Drain bottom trap-assisted voltage dependent parameter	–	10
VTSS	Source bottom trap-assisted voltage dependent parameter	–	10
VTSSWD	Drain STI sidewall trap-assisted voltage dependent parameter	–	10
VTSSWGD	Drain gate-edge sidewall trap-assisted voltage dependent parameter	–	10
VTSSWGS	Source gate-edge sidewall trap-assisted voltage dependent parameter	–	10
VTSSWS	Source STI sidewall trap-assisted voltage dependent parameter	–	10
WA0	Width dependence of a0	–	0
WA1	Width dependence of a1	–	0
WA2	Width dependence of a2	–	0
WACDE	Width dependence of acde	–	0
WAGIDL	Width dependence of agidl	–	0
WAGISL	Width dependence of agisl	–	0
WAGS	Width dependence of ags	–	0
WAIGBACC	Width dependence of aigbacc	–	0
WAIGBINV	Width dependence of aigbinv	–	0
WAIGC	Width dependence of aigc	–	0
WAIGD	Width dependence of aigd	–	0
WAIGS	Width dependence of aigs	–	0
WAIGSD	Width dependence of aigsd	–	0

Parameter	Description	Units	Default
WALPHA0	Width dependence of alpha0	–	0
WALPHA1	Width dependence of alpha1	–	0
WAT	Width dependence of at	–	0
WB0	Width dependence of b0	–	0
WB1	Width dependence of b1	–	0
WBETA0	Width dependence of beta0	–	0
WBGIDL	Width dependence of bgidl	–	0
WBGISL	Width dependence of bgisl	–	0
WBIGBACC	Width dependence of bigbacc	–	0
WBIGBINV	Width dependence of bigbinv	–	0
WBIGC	Width dependence of bigc	–	0
WBIGD	Width dependence of bigd	–	0
WBIGS	Width dependence of bigs	–	0
WBIGSD	Width dependence of bigsd	–	0
WCDS	Width dependence of cdsc	–	0
WCDSB	Width dependence of cdsb	–	0
WCSD	Width dependence of cdsd	–	0
WCF	Width dependence of cf	–	0
WCGDL	Width dependence of cgdl	–	0
WCGIDL	Width dependence of cgidl	–	0
WCGISL	Width dependence of cgisl	–	0
WCGSL	Width dependence of cgsl	–	0
WCIGBACC	Width dependence of cigbacc	–	0
WCIGBINV	Width dependence of cigbinv	–	0
WCIGC	Width dependence of cigc	–	0
WCIGD	Width dependence of cigd	–	0
WCIGS	Width dependence of cigs	–	0
WCIGSD	Width dependence of cigsd	–	0
WCIT	Width dependence of cit	–	0
WCKAPPAD	Width dependence of ckappad	–	0

Parameter	Description	Units	Default
WCKAPPAS	Width dependence of ckappas	–	0
WCLC	Width dependence of clc	–	0
WCLE	Width dependence of cle	–	0
WDELTA	Width dependence of delta	–	0
WDROUT	Width dependence of drout	–	0
WDSUB	Width dependence of dsub	–	0
WDVT0	Width dependence of dvt0	–	0
WDVT0W	Width dependence of dvt0w	–	0
WDVT1	Width dependence of dvt1	–	0
WDVT1W	Width dependence of dvt1w	–	0
WDVT2	Width dependence of dvt2	–	0
WDVT2W	Width dependence of dvt2w	–	0
WDVTP0	Width dependence of dvtp0	–	0
WDVTP1	Width dependence of dvtp1	–	0
WDWB	Width dependence of dwb	–	0
WDWG	Width dependence of dwg	–	0
WEB	Coefficient for SCB	–	0
WEC	Coefficient for SCC	–	0
WEGIDL	Width dependence of egidl	–	0
WEGISL	Width dependence of egisl	–	0
WEIGBINV	Width dependence for eigbinv	–	0
WETA0	Width dependence of eta0	–	0
WETAB	Width dependence of etab	–	0
WEU	Width dependence of eu	–	0
WFPROUT	Width dependence of pdiblcb	–	0
WGAMMA1	Width dependence of gamma1	–	0
WGAMMA2	Width dependence of gamma2	–	0
WK1	Width dependence of k1	–	0
WK2	Width dependence of k2	–	0
WK2WE	Width dependence of k2we	–	0

Parameter	Description	Units	Default
WK3	Width dependence of k3	–	0
WK3B	Width dependence of k3b	–	0
WKETA	Width dependence of keta	–	0
WKT1	Width dependence of kt1	–	0
WKT1L	Width dependence of kt1l	–	0
WKT2	Width dependence of kt2	–	0
WKU0	Width dependence of ku0	–	0
WKUOWE	Width dependence of ku0we	–	0
WKVTH0	Width dependence of kvth0	–	0
WKVTHOWE	Width dependence of kvth0we	–	0
WL	Width reduction parameter	–	0
WLAMBDA	Width dependence of lambda	–	0
WLC	Width reduction parameter for CV	–	0
WLN	Width reduction parameter	–	1
WLOD	Width parameter for stress effect	–	0
WLODKU0	Width parameter for u0 LOD effect	–	0
WLODVTH	Width parameter for vth LOD effect	–	0
WLP	Width dependence of lp	–	0
WLPE0	Width dependence of lpe0	–	0
WLPEB	Width dependence of lpeb	–	0
WMAX	Maximum width for the model	–	1
WMIN	Minimum width for the model	–	0
WMINV	Width dependence of minv	–	0
WMINVCV	Width dependence of minvcv	–	0
WMOIN	Width dependence of moin	–	0
WNDEP	Width dependence of ndep	–	0
WNFACTOR	Width dependence of nfactor	–	0
WNGATE	Width dependence of ngate	–	0
WNIGBACC	Width dependence of nigbacc	–	0
WNIGBINV	Width dependence of nigbinv	–	0

Parameter	Description	Units	Default
WNIGC	Width dependence of nigc	–	0
WNOFF	Width dependence of noff	–	0
WNSD	Width dependence of nsd	–	0
WNSUB	Width dependence of nsub	–	0
WNTOX	Width dependence of ntox	–	0
WPCLM	Width dependence of pclm	–	0
WPDIBLC1	Width dependence of pdiblc1	–	0
WPDIBLC2	Width dependence of pdiblc2	–	0
WPDIBLCB	Width dependence of pdiblcb	–	0
WPDITS	Width dependence of pdits	–	0
WPDITSD	Width dependence of pditsd	–	0
WPEMOD	Flag for WPE model (WPEMOD=1 to activate this model)	–	0
WPHIN	Width dependence of phin	–	0
WPIGCD	Width dependence for pigcd	–	0
WPOXEDGE	Width dependence for poxedge	–	0
WPRT	Width dependence of prt	–	0
WPRWB	Width dependence of prwb	–	0
WPRWG	Width dependence of prwg	–	0
WPSCBE1	Width dependence of pscbe1	–	0
WPSCBE2	Width dependence of pscbe2	–	0
WPVAG	Width dependence of pvag	–	0
WRDSW	Width dependence of rdsw	–	0
WRDW	Width dependence of rdw	–	0
WRSW	Width dependence of rsw	–	0
WTVFBSDOFF	Width dependence of tvfbsdoff	–	0
WTVOFF	Width dependence of tvoff	–	0
WU0	Width dependence of u0	–	0
WUA	Width dependence of ua	–	0
WUA1	Width dependence of ua1	–	0

Parameter	Description	Units	Default
WUB	Width dependence of ub	–	0
WUB1	Width dependence of ub1	–	0
WUC	Width dependence of uc	–	0
WUC1	Width dependence of uc1	–	0
WUD	Width dependence of ud	–	0
WUD1	Width dependence of ud1	–	0
WUP	Width dependence of up	–	0
WUTE	Width dependence of ute	–	0
WVBM	Width dependence of vbm	–	0
WVBX	Width dependence of vbx	–	0
WVFB	Width dependence of vfb	–	0
WVFCV	Width dependence of vfbcv	–	0
WFBSDOFF	Width dependence of vfbsdoff	–	0
WVOFF	Width dependence of voff	–	0
WVOFCV	Width dependence of voffcv	–	0
WVSAT	Width dependence of vsat	–	0
WVTHO		–	0
WVTL	Width dependence of vtl	–	0
WW	Width reduction parameter	–	0
WWO	Width dependence of w0	–	0
WWC	Width reduction parameter for CV	–	0
WWL	Width reduction parameter	–	0
WWLC	Width reduction parameter for CV	–	0
WWN	Width reduction parameter	–	1
WWR	Width dependence of wr	–	0
WXJ	Width dependence of xj	–	0
WXN	Width dependence of xn	–	0
WXRCRG1	Width dependence of xrcrg1	–	0
WXRCRG2	Width dependence of xrcrg2	–	0
WXT	Width dependence of xt	–	0

Parameter	Description	Units	Default
XGL	Variation in Ldrawn	–	0
XGW	Distance from gate contact center to device edge	–	0
XJBVD	Fitting parameter for drain diode breakdown current	–	1
XJBVS	Fitting parameter for source diode breakdown current	–	1
XL	L offset for channel length due to mask/etch effect	–	0
XRCRG1	First fitting parameter the bias-dependent Rg	–	12
XRCRG2	Second fitting parameter the bias-dependent Rg	–	1
XTID	Drainjunction current temperature exponent	–	3
XTIS	Source junction current temperature exponent	–	3
XTSD	Power dependence of JTSD on temperature	–	0.02
XTSS	Power dependence of JTSS on temperature	–	0.02
XTSSWD	Power dependence of JTSSWD on temperature	–	0.02
XTSSWGD	Power dependence of JTSSWGD on temperature	–	0.02
XTSSWGS	Power dependence of JTSSWGS on temperature	–	0.02
XTSSWS	Power dependence of JTSSWS on temperature	–	0.02
XW	W offset for channel width due to mask/etch effect	–	0
<b>Basic Parameters</b>			
A0	Non-uniform depletion width effect coefficient.	–	1
A1	Non-saturation effect coefficient	V <sup>-1</sup>	0
A2	Non-saturation effect coefficient	–	1
ADOS	Charge centroid parameter	–	1
AGS	Gate bias coefficient of Abulk.	V <sup>-1</sup>	0
B0	Abulk narrow width parameter	m	0
B1	Abulk narrow width parameter	m	0
BDOS	Charge centroid parameter	–	1
BGOSUB	Band-gap of substrate at T=0K	eV	1.16
CDSC	Drain/Source and channel coupling capacitance	F/m <sup>2</sup>	0.00024
CDSCB	Body-bias dependence of cdsc	F/(Vm <sup>2</sup> )	0
CDSCD	Drain-bias dependence of cdsc	F/(Vm <sup>2</sup> )	0
CIT	Interface state capacitance	F/m <sup>2</sup>	0

Parameter	Description	Units	Default
DELTA	Effective Vds parameter	V	0.01
DROUT	DIBL coefficient of output resistance	–	0.56
DSUB	DIBL coefficient in the subthreshold region	–	0.56
DVT0	Short channel effect coeff. 0	–	2.2
DVT0W	Narrow Width coeff. 0	–	0
DVT1	Short channel effect coeff. 1	–	0.53
DVT1W	Narrow Width effect coeff. 1	m <sup>-1</sup>	5.3e+06
DVT2	Short channel effect coeff. 2	V <sup>-1</sup>	-0.032
DVT2W	Narrow Width effect coeff. 2	V <sup>-1</sup>	-0.032
DVTP0	First parameter for Vth shift due to pocket	m	0
DVTP1	Second parameter for Vth shift due to pocket	V <sup>-1</sup>	0
DWB	Width reduction parameter	m/V <sup>1/2</sup>	0
DWG	Width reduction parameter	m/V	0
EASUB	Electron affinity of substrate	V	4.05
EPSRSUB	Dielectric constant of substrate relative to vacuum	–	11.7
ETA0	Subthreshold region DIBL coefficient	–	0.08
ETAB	Subthreshold region DIBL coefficient	V <sup>-1</sup>	-0.07
EU	Mobility exponent	–	1.67
FPROUT	Rout degradation coefficient for pocket devices	V/m <sup>1/2</sup>	0
K1	Bulk effect coefficient 1	V <sup>-1/2</sup>	0
K2	Bulk effect coefficient 2	–	0
K3	Narrow width effect coefficient	–	80
KETA	Body-bias coefficient of non-uniform depletion width effect.	V <sup>-1</sup>	-0.047
LAMBDA	Velocity overshoot parameter	–	0
LC	back scattering parameter	m	5e-09
LINT	Length reduction parameter	m	0
LP	Channel length exponential factor of mobility	m	1e-08
LPE0	Equivalent length of pocket region at zero bias	m	1.74e-07

Parameter	Description	Units	Default
LPEB	Equivalent length of pocket region accounting for body bias	m	0
MINV	Fitting parameter for moderate inversion in Vgsteff	–	0
NFACTOR	Subthreshold swing Coefficient	–	1
NIOSUB	Intrinsic carrier concentration of substrate at 300.15K	cm <sup>-3</sup>	1.45e+10
PCLM	Channel length modulation Coefficient	–	1.3
PDIBLC1	Drain-induced barrier lowering coefficient	–	0.39
PDIBLC2	Drain-induced barrier lowering coefficient	–	0.0086
PDIBLCB	Body-effect on drain-induced barrier lowering	V <sup>-1</sup>	0
PDITS	Coefficient for drain-induced Vth shifts	V <sup>-1</sup>	0
PDITSD	Vds dependence of drain-induced Vth shifts	V <sup>-1</sup>	0
PDITSL	Length dependence of drain-induced Vth shifts	m <sup>-1</sup>	0
PHIN	Adjusting parameter for surface potential due to non-uniform vertical doping	V	0
PSCBE1	Substrate current body-effect coefficient	V/m	4.24e+08
PSCBE2	Substrate current body-effect coefficient	m/V	1e-05
TBGASUB	First parameter of band-gap change due to temperature	eV/°K	0.000702
TBGBSUB	Second parameter of band-gap change due to temperature	°K	1108
U0	Low-field mobility at Tnom	m <sup>2</sup> /(Vs)	0.067
UA	Linear gate dependence of mobility	m/V	1e-09
UB	Quadratic gate dependence of mobility	m <sup>2</sup> /V <sup>2</sup>	1e-19
UC	Body-bias dependence of mobility	V <sup>-1</sup>	-4.65e-11
UD	Coulomb scattering factor of mobility	m <sup>-2</sup>	0
UP	Channel length linear factor of mobility	m <sup>-2</sup>	0
VBM	Maximum body voltage	V	-3
VDDEOT	Voltage for extraction of equivalent gate oxide thickness	V	1.5
VFB	Flat Band Voltage	V	-1
VOFF	Threshold voltage offset	V	-0.08
VOFFL	Length dependence parameter for Vth offset	V	0

Parameter	Description	Units	Default
VSAT	Saturation velocity at tnom	m/s	80000
VTH0		V	0.7
VTL	thermal velocity	m/s	200000
W0	Narrow width effect parameter	m	2.5e-06
WINT	Width reduction parameter	m	0
XN	back scattering parameter	-	3
<b>Capacitance Parameters</b>			
ACDE	Exponential coefficient for finite charge thickness	m/V	1
CF	Fringe capacitance parameter	F/m	1.07725e-10
CGBO	Gate-bulk overlap capacitance per length	-	0
CGDL	New C-V model parameter	F/m	0
CGDO	Gate-drain overlap capacitance per width	F/m	1.03594e-09
CGSL	New C-V model parameter	F/m	0
CGSO	Gate-source overlap capacitance per width	F/m	1.03594e-09
CKAPPAD	D/G overlap C-V parameter	V	0.6
CKAPPAS	S/G overlap C-V parameter	V	0.6
CLC	Vdsat parameter for C-V model	m	1e-07
CLE	Vdsat parameter for C-V model	-	0.6
DLC	Delta L for C-V model	m	0
DWC	Delta W for C-V model	m	0
MINVCV	Fitting parameter for moderate inversion in Vgsteffcv	-	0
MOIN	Coefficient for gate-bias dependent surface potential	-	15
NOFF	C-V turn-on/off parameter	-	1
VFBCV	Flat Band Voltage parameter for capmod=0 only	V	-1
VOFFCV	C-V lateral-shift parameter	V	0
VOFFCVL	Length dependence parameter for Vth offset in CV	-	0
XPART	Channel charge partitioning	F/m	0
<b>Control Parameters</b>			

Parameter	Description	Units	Default
ACNQSMOD	AC NQS model selector	–	0
BINUNIT	Bin unit selector	–	1
CAPMOD	Capacitance model selector	–	2
CVCHARGEMOD	Capacitance charge model selector	–	0
DIOMOD	Diode IV model selector	–	1
FNOIMOD	Flicker noise model selector	–	1
GEOMOD	Geometry dependent parasitics model selector	–	0
IGBMOD	Gate-to-body I <sub>g</sub> model selector	–	0
IGCMOD	Gate-to-channel I <sub>g</sub> model selector	–	0
MOBMOD	Mobility model selector	–	0
MTRLMOD	parameter for nonm-silicon substrate or metal gate selector	–	0
PARAMCHK	Model parameter checking selector	–	1
PERMOD	Pd and Ps model selector	–	1
RBODYMOD	Distributed body R model selector	–	0
RDSMOD	Bias-dependent S/D resistance model selector	–	0
RGATEMOD	Gate R model selector	–	0
TEMPMOD	Temperature model selector	–	0
TNOIMOD	Thermal noise model selector	–	0
TRNQSMOD	Transient NQS model selector	–	0
VERSION	parameter for model version	–	4.6.1
<b><i>Flicker Parameters</i></b>			
NOIA	Flicker Noise parameter a	–	6.25e+41
NOIB	Flicker Noise parameter b	–	3.125e+26
NOIC	Flicker Noise parameter c	–	8.75e+09
<b><i>Process Parameters</i></b>			
DTOX	Defined as (toxe - toxp)	m	0
EOT	Equivalent gate oxide thickness in meters	m	1.5e-09
EPSROX	Dielectric constant of the gate oxide relative to vacuum	–	3.9
GAMMA1	V <sub>th</sub> body coefficient	V <sup>1/2</sup>	0
GAMMA2	V <sub>th</sub> body coefficient	V <sup>1/2</sup>	0

Parameter	Description	Units	Default
NDEP	Channel doping concentration at the depletion edge	cm <sup>-3</sup>	1.7e+17
NGATE	Poly-gate doping concentration	cm <sup>-3</sup>	0
NSD	S/D doping concentration	cm <sup>-3</sup>	1e+20
NSUB	Substrate doping concentration	cm <sup>-3</sup>	6e+16
RSH	Source-drain sheet resistance	ohm/square	0
RSHG	Gate sheet resistance	ohm/square	0.1
TOXE	Electrical gate oxide thickness in meters	m	3e-09
TOXM	Gate oxide thickness at which parameters are extracted	m	3e-09
TOXP	Physical gate oxide thickness in meters	m	3e-09
VBX	Vth transition body Voltage	V	0
XJ	Junction depth in meters	m	1.5e-07
XT	Doping depth	m	1.55e-07
<b><i>Tunnelling Parameters</i></b>			
AIGBACC	Parameter for Igb	(Fs <sup>2</sup> /g) <sup>1/2</sup> /n	0.0136
AIGBINV	Parameter for Igb	(Fs <sup>2</sup> /g) <sup>1/2</sup> /n	0.0111
AIGC	Parameter for Igc	(Fs <sup>2</sup> /g) <sup>1/2</sup> /n	0.0136
AIGD	Parameter for Igd	(Fs <sup>2</sup> /g) <sup>1/2</sup> /n	0.0136
AIGS	Parameter for Igs	(Fs <sup>2</sup> /g) <sup>1/2</sup> /n	0.0136
BIGBACC	Parameter for Igb	(Fs <sup>2</sup> /g) <sup>1/2</sup> /n	0.00171
BIGBINV	Parameter for Igb	(Fs <sup>2</sup> /g) <sup>1/2</sup> /n	0.000949
BIGC	Parameter for Igc	(Fs <sup>2</sup> /g) <sup>1/2</sup> /n	0.00171
BIGD	Parameter for Igd	(Fs <sup>2</sup> /g) <sup>1/2</sup> /n	0.00171
BIGS	Parameter for Igs	(Fs <sup>2</sup> /g) <sup>1/2</sup> /n	0.00171
CIGBACC	Parameter for Igb	V <sup>-1</sup>	0.075
CIGBINV	Parameter for Igb	V <sup>-1</sup>	0.006
CIGC	Parameter for Igc	V <sup>-1</sup>	0.075
CIGD	Parameter for Igd	V <sup>-1</sup>	0.075
CIGS	Parameter for Igs	V <sup>-1</sup>	0.075
DLICGD	Delta L for Ig model drain side	m	0

Parameter	Description	Units	Default
EIGBINV	Parameter for the Si bandgap for Igbinv	V	1.1
NIGBACC	Parameter for Igbacc slope	–	1
NIGBINV	Parameter for Igbinv slope	–	3
NIGC	Parameter for Igc slope	–	1
NTOX	Exponent for Tox ratio	–	1
PIGCD	Parameter for Igc partition	–	1
POXEDGE	Factor for the gate edge Tox	–	1
TOXREF	Target tox value	m	3e-09
VFBSDOFF	S/D flatband voltage offset	V	0
<b><i>Asymmetric and Bias-Dependent <math>R_{ds}</math> Parameters</i></b>			
PRWB	Body-effect on parasitic resistance	$V^{-1}$	0
PRWG	Gate-bias effect on parasitic resistance	$V^{-1}$	1
RDSW	Source-drain resistance per width	$\Omega - \mu\text{m}$	200
RDSWMIN	Source-drain resistance per width at high Vg	$\Omega - \mu\text{m}$	0
RDW	Drain resistance per width	$\Omega - \mu\text{m}$	100
RDWMIN	Drain resistance per width at high Vg	$\Omega - \mu\text{m}$	0
RSW	Source resistance per width	$\Omega - \mu\text{m}$	100
RSWMIN	Source resistance per width at high Vg	$\Omega - \mu\text{m}$	0
WR	Width dependence of rds	–	1
<b><i>Impact Ionization Current Parameters</i></b>			
ALPHAO	substrate current model parameter	m/V	0
ALPHA1	substrate current model parameter	$V^{-1}$	0
BETAO	substrate current model parameter	$V^{-1}$	0
<b><i>Gate-induced Drain Leakage Model Parameters</i></b>			
AGIDL	Pre-exponential constant for GIDL	$\Omega^{-1}$	0
AGISL	Pre-exponential constant for GISL	$\Omega^{-1}$	0
BGIDL	Exponential constant for GIDL	V/m	2.3e+09
BGISL	Exponential constant for GISL	V/m	2.3e-09
CGIDL	Parameter for body-bias dependence of GIDL	$V^3$	0.5
CGISL	Parameter for body-bias dependence of GISL	$V^3$	0.5
EGIDL	Fitting parameter for Bandbending	V	0.8

Parameter	Description	Units	Default
EGISL	Fitting parameter for Bandbending	V	0.8

Table 2.33: BSIM4 Device Model Parameters.

### Model level 18 (VDMOS)

The vertical double-diffused power MOSFET model is based on the uniform charge control model (UCCM) developed at Rensselaer Polytechnic Institute [13]. The VDMOS current-voltage characteristics are described by a single, continuous analytical expression for all regimes of operation. The physics-based model includes effects such as velocity saturation in the channel, drain induced barrier lowering, finite output conductance in saturation, the quasi-saturation effect through a bias dependent drain parasitic resistance, effects of bulk charge, and bias dependent low-field mobility. An important feature of the implementation is the utilization of a single continuous expression for the drain current, which is valid below and above threshold, effectively removing discontinuities and improving convergence properties.

The following tables give parameters for the level 18 MOSFET.

Parameter	Description	Units	Default
AD	Drain diffusion area	m <sup>2</sup>	0
AS	Source diffusion area	m <sup>2</sup>	0
L	Channel length	m	0.0001
M	Multiplier for M devices connected in parallel	–	1
NRD	Multiplier for RSH to yield parasitic resistance of drain	squares	0
NRS	Multiplier for RSH to yield parasitic resistance of source	squares	0
PD	Drain diffusion perimeter	m	0
PS	Source diffusion perimeter	m	0
TEMP	Device temperature	°C	27
W	Channel width	m	0.0001

Table 2.34: Power MOSFET Device Parameters.

Parameter	Description	Units	Default
ALPHA	Parameter accounting for the threshold dependence on the channel potential	–	1.05
CBD	Zero-bias bulk-drain p-n capacitance	F	0
CBS	Zero-bias bulk-source p-n capacitance	F	0
CGBO	Gate-bulk overlap capacitance/channel length	F/m	0
CGDO	Gate-drain overlap capacitance/channel width	F/m	0
CGSO	Gate-source overlap capacitance/channel width	F/m	0
CJ	Bulk p-n zero-bias bottom capacitance/area	F/m <sup>2</sup>	0
CJSW	Bulk p-n zero-bias sidewall capacitance/area	F/m <sup>2</sup>	0
CV	Charge model storage selector	–	1
CVE	Meyer-like capacitor model selector	–	1
D1AF	Drain-source diode flicker noise exponent	–	1
D1BV	Drain-source diode reverse breakdown voltage	V	1e+99
D1CJO	Drain-source diode junction capacitance	F	0
D1EG	Drain-source diode activation energy	eV	1.11
D1FC	Drain-source diode forward bias depletion capacitance	–	0.5
D1IBV	Drain-source diode current at breakdown voltage	A	0.001
D1IKF	Drain-source diode high injection knee current	A	0
D1IS	Drain-Source diode saturation current	A	1e-14
D1ISR	Drain-source diode recombination saturation current	A	0
D1KF	Drain-source diode flicker noise coefficient	–	0
D1M	Drain-source diode grading coefficient	–	0.5
D1N	Drain-source diode emission coefficient	–	1
D1NR	Drain-source diode recombination emission coefficient	–	2
D1RS	Drain-source diode ohmic resistance	Ω	0
D1TNOM	Drain-source diode nominal temperature	°C	300.15
D1TT	Drain-source diode transit time	s	0
D1VJ	Drain-source diode junction potential	V	1
D1XTI	Drain-source diode sat. current temperature exponent	–	3
DELTA	Transition width parameter	–	5

Parameter	Description	Units	Default
DRIFTPARAMA	Drift region resistance intercept parameter	$\Omega$	0.08
DRIFTPARAMB	Drift region resistance slope parameter	ohm/volt	0.013
ETA	Subthreshold ideality factor	–	1.32
FC	Coefficient for forward-bias depletion capacitance formula	–	0.5
FPE	Charge partitioning scheme selector	–	1
GAMMALO	Body effect constant in front of linear term	–	0
GAMMASO	Body effect constant in front of square root term	$V^{-1/2}$	0.5
IS	Bulk p-n saturation current	A	1e-14
JS	Bulk p-n saturation current density	$A/m^2$	0
L0	Gate length of nominal device	m	0.0001
LAMBDA	Output conductance parameter	$V^{-1}$	0.048
LD	Lateral diffusion length	m	0
LGAMMAL	Sensitivity of gL on device length	–	0
LGAMMAS	Sensitivity of gS on device length	$V^{-1/2}$	0
M	Knee shape parameter	–	4
MCV	Transition width parameter used by the charge partitioning scheme	–	10
MJ	Bulk p-n bottom grading coefficient	–	0.5
MJSW	Bulk p-n sidewall grading coefficient	–	0.5
NSS	Surface state density	$cm^{-2}$	0
NSUB	Substrate doping density	$cm^{-3}$	0
PB	Bulk p-n bottom potential	V	0.8
PHI	Surface potential	V	0.6
RD	Drain ohmic resistance	$\Omega$	0
RDSSHUNT	Drain-source shunt resistance	$\Omega$	0
RG	Gate ohmic resistance	$\Omega$	0
RS	Source ohmic resistance	$\Omega$	0
RSH	Drain, source diffusion sheet resistance	$\Omega$	0
SIGMA0	DIBL parameter	–	0.048

Parameter	Description	Units	Default
TEMPMODEL	Specification to type of parameter interpolation over temperature (see User Guide section 5.3	–	NONE
THETA	Mobility degradation parameter	m/V	0
TNOM	Nominal device temperature	°C	27
TOX	Gate oxide thickness	m	1e-07
TPG	Gate material type (-1 = same as substrate, 0 = aluminum, 1 = opposite of substrate	–	1
U0	Surface mobility	1/(Vcm <sup>2</sup> s)	280
VFB	Flat band voltage	V	1e-12
VMAX	Maximum drift velocity for carriers	m/s	40000
VSIGMA	DIBL parameter	V	0.2
VSIGMAT	DIBL parameter	V	1.7
VTO	Zero-bias threshold voltage	V	0
W0	Gate width of nominal device	m	0.0001
WGAMMAL	Sensitivity of gL on device width	–	0
WGAMMAS	Sensitivity of gS on device width	V <sup>-1/2</sup>	0
XJ	Metallurgical junction depth	m	0
XQC	Charge partitioning factor	–	0.6

Table 2.35: Power MOSFET Model Parameters.

### Model level 103 (PSP version 103.1)

As of Release 5.2, **Xyce** includes the PSP MOSFET model, version 103.1 [14]. Full documentation for the PSP model is available on its web site, [http://pspmodel.asu.edu/psp\\_documentation.htm](http://pspmodel.asu.edu/psp_documentation.htm). Instance and model parameters for the PSP model are given in tables 2.36 and 2.37.

Parameter	Description	Units	Default
ABDRAIN	Bottom area of drain junction	–	1e-12
ABSOURCE	Bottom area of source junction	–	1e-12
AD	Bottom area of drain junction	–	1e-12
AS	Bottom area of source junction	–	1e-12

Parameter	Description	Units	Default
DELVTO	Threshold voltage shift parameter	–	0
FACTUO	Zero-field mobility pre-factor	–	1
JW	Gate-edge length of source/drain junction	–	1e-06
L	Design length	–	1e-05
LGDRAIN	Gate-edge length of drain junction	–	1e-06
LGSOURCE	Gate-edge length of source junction	–	1e-06
LSDRAIN	STI-edge length of drain junction	–	1e-06
LSSOURCE	STI-edge length of source junction	–	1e-06
MULT	Number of devices in parallel	–	1
NF	Number of fingers	–	1
NGCON	Number of gate contacts	–	1
NRD	Number of squares of drain diffusion	–	0
NRS	Number of squares of source diffusion	–	0
PD	Perimeter of drain junction	–	1e-06
PS	Perimeter of source junction	–	1e-06
SA	Distance between OD-edge and poly from one side	–	0
SB	Distance between OD-edge and poly from other side	–	0
SC	Distance between OD-edge and nearest well edge	–	0
SCA	Integral of the first distribution function for scattered well dopants	–	0
SCB	Integral of the second distribution function for scattered well dopants	–	0
SCC	Integral of the third distribution function for scattered well dopants	–	0
SD	Distance between neighbouring fingers	–	0
W	Design width	–	1e-05
XGW	Distance from the gate contact to the channel edge	–	1e-07

Table 2.36: PSP103VA MOSFET Device Instance Parameters.

Parameter	Description	Units	Default
A1	Impact-ionization pre-factor	–	1

Parameter	Description	Units	Default
A1L	Length dependence of A1	–	0
A10	Geometry independent impact-ionization pre-factor	–	1
A1W	Width dependence of A1	–	0
A2	Impact-ionization exponent at TR	V	10
A20	Impact-ionization exponent at TR	V	10
A3	Saturation-voltage dependence of impact-ionization	–	1
A3L	Length dependence of A3	–	0
A30	Geometry independent saturation-voltage dependence of II	–	1
A3W	Width dependence of A3	–	0
A4	Back-bias dependence of impact-ionization	$V^{-1/2}$	0
A4L	Length dependence of A4	–	0
A40	Geometry independent back-bias dependence of II	$V^{-1/2}$	0
A4W	Width dependence of A4	–	0
AGIDL	GIDL pre-factor	$A/V^3$	0
AGIDLD	GIDL pre-factor for drain side	$A/V^3$	0
AGIDLDW	Width dependence of GIDL pre-factor for drain side	$A/V^3$	0
AGIDLW	Width dependence of GIDL pre-factor	$A/V^3$	0
ALP	CLM pre-factor	–	0.01
ALP1	CLM enhancement factor above threshold	V	0
ALP1L1	Length dependence of CLM enhancement factor above threshold	V	0
ALP1L2	Second order length dependence of ALP1	–	0
ALP1LEXP	Exponent for length dependence of ALP1	–	0.5
ALP1W	Width dependence of ALP1	–	0
ALP2	CLM enhancement factor below threshold	$V^{-1}$	0
ALP2L1	Length dependence of CLM enhancement factor below threshold	$V^{-1}$	0
ALP2L2	Second order length dependence of ALP2	–	0
ALP2LEXP	Exponent for length dependence of ALP2	–	0.5
ALP2W	Width dependence of ALP2	–	0

Parameter	Description	Units	Default
ALPL	Length dependence of ALP	–	0.0005
ALPLEXP	Exponent for length dependence of ALP	–	1
ALPNOI	Exponent for length offset for flicker noise	–	2
ALPW	Width dependence of ALP	–	0
AX	Linear/saturation transition factor	–	3
AXL	Length dependence of AX	–	0.4
AXO	Geometry independent linear/saturation transition factor	–	18
BETN	Channel aspect ratio times zero-field mobility	m <sup>2</sup> /(Vs)	0.07
BETW1	First higher-order width scaling coefficient of BETN	–	0
BETW2	Second higher-order width scaling coefficient of BETN	–	0
BGIDL	GIDL probability factor at TR	V	41
BGIDLD	GIDL probability factor at TR for drain side	V	41
BGIDLDO	GIDL probability factor at TR for drain side	V	41
BGIDL0	GIDL probability factor at TR	V	41
CBBTBOT	Band-to-band tunneling prefactor of bottom component for source-bulk junction	–	1e-12
CBBTBOTD	Band-to-band tunneling prefactor of bottom component for drain-bulk junction	–	1e-12
CBBTGAT	Band-to-band tunneling prefactor of gate-edge component for source-bulk junction	–	1e-18
CBBTGATD	Band-to-band tunneling prefactor of gate-edge component for drain-bulk junction	–	1e-18
CBBTSTI	Band-to-band tunneling prefactor of STI-edge component for source-bulk junction	–	1e-18
CBBTSTID	Band-to-band tunneling prefactor of STI-edge component for drain-bulk junction	–	1e-18
CF	DIBL-parameter	–	0
CFB	Back bias dependence of CF	V <sup>-1</sup>	0
CFBO	Back-bias dependence of CF	V <sup>-1</sup>	0
CFL	Length dependence of DIBL-parameter	–	0
CFLEXP	Exponent for length dependence of CF	–	2
CFR	Outer fringe capacitance	F	0

Parameter	Description	Units	Default
CFRD	Outer fringe capacitance for drain side	F	0
CFRDW	Outer fringe capacitance for 1 um wide channel for drain side	F	0
CFRW	Outer fringe capacitance for 1 um wide channel	F	0
CFW	Width dependence of CF	–	0
CGBOV	Oxide capacitance for gate-bulk overlap	F	0
CGBOVL	Oxide capacitance for gate-bulk overlap for 1 um long channel	F	0
CGIDL	Back-bias dependence of GIDL	–	0
CGIDLD	Back-bias dependence of GIDL for drain side	–	0
CGIDLDO	Back-bias dependence of GIDL for drain side	–	0
CGIDL0	Back-bias dependence of GIDL	–	0
CGOV	Oxide capacitance for gate-drain/source overlap	F	1e-15
CGOVD	Oxide capacitance for gate-drain overlap	F	1e-15
CHIB	Tunneling barrier height	V	3.1
CHIB0	Tunneling barrier height	V	3.1
CJORBOT	Zero-bias capacitance per unit-of-area of bottom component for source-bulk junction	–	0.001
CJORBOTD	Zero-bias capacitance per unit-of-area of bottom component for drain-bulk junction	–	0.001
CJORGAT	Zero-bias capacitance per unit-of-length of gate-edge component for source-bulk junction	–	1e-09
CJORGATD	Zero-bias capacitance per unit-of-length of gate-edge component for drain-bulk junction	–	1e-09
CJORSTI	Zero-bias capacitance per unit-of-length of STI-edge component for source-bulk junction	–	1e-09
CJORSTID	Zero-bias capacitance per unit-of-length of STI-edge component for drain-bulk junction	–	1e-09
COX	Oxide capacitance for intrinsic channel	F	1e-14
CS	Coulomb scattering parameter at TR	–	0
CSL	Length dependence of CS	–	0
CSLEXP	Exponent for length dependence of CS	–	1
CSLW	Area dependence of CS	–	0

Parameter	Description	Units	Default
CS0	Geometry independent coulomb scattering parameter at TR	–	0
CSRHBOT	Shockley-Read-Hall prefactor of bottom component for source-bulk junction	–	100
CSRHBOTD	Shockley-Read-Hall prefactor of bottom component for drain-bulk junction	–	100
CSRHGAT	Shockley-Read-Hall prefactor of gate-edge component for source-bulk junction	–	0.0001
CSRHGATD	Shockley-Read-Hall prefactor of gate-edge component for drain-bulk junction	–	0.0001
CSRHSTI	Shockley-Read-Hall prefactor of STI-edge component for source-bulk junction	–	0.0001
CSRHSTID	Shockley-Read-Hall prefactor of STI-edge component for drain-bulk junction	–	0.0001
CSW	Width dependence of CS	–	0
CT	Interface states factor	–	0
CTATBOT	Trap-assisted tunneling prefactor of bottom component for source-bulk junction	–	100
CTATBOTD	Trap-assisted tunneling prefactor of bottom component for drain-bulk junction	–	100
CTATGAT	Trap-assisted tunneling prefactor of gate-edge component for source-bulk junction	–	0.0001
CTATGATD	Trap-assisted tunneling prefactor of gate-edge component for drain-bulk junction	–	0.0001
CTATSTI	Trap-assisted tunneling prefactor of STI-edge component for source-bulk junction	–	0.0001
CTATSTID	Trap-assisted tunneling prefactor of STI-edge component for drain-bulk junction	–	0.0001
CTL	Length dependence of interface states factor	–	0
CTLEXP	Exponent for length dependence of interface states factor	–	1
CTLW	Area dependence of interface states factor	–	0
CT0	Geometry-independent interface states factor	–	0
CTW	Width dependence of interface states factor	–	0

Parameter	Description	Units	Default
DELVTAC	Offset parameter for PHIB in separate charge calculation	V	0
DELVTACL	Length dependence of DELVTAC	V	0
DELVTACLEXP	Exponent for length dependence of offset of DELVTAC	–	1
DELVTACLW	Area dependence of DELVTAC	V	0
DELVTACO	Geom. independent offset parameter for PHIB in separate charge calculation	V	0
DELVTACW	Width dependence of DELVTAC	V	0
DLQ	Effective channel length reduction for CV	m	0
DLSIL	Silicide extension over the physical gate length	m	0
DNSUB	Effective doping bias-dependence parameter	V <sup>-1</sup>	0
DNSUBO	Effective doping bias-dependence parameter	V <sup>-1</sup>	0
DPHIB	Offset parameter for PHIB	V	0
DPHIBL	Length dependence offset of PHIB	V	0
DPHIBLEXP	Exponent for length dependence of offset of PHIB	–	1
DPHIBLW	Area dependence of offset of PHIB	V	0
DPHIBO	Geometry independent offset of PHIB	V	0
DPHIBW	Width dependence of offset of PHIB	V	0
DTA	Temperature offset w.r.t. ambient temperature	°K	0
DVSBNUD	Vsb-range for NUD-effect	V	1
DVSBNUDO	Vsb range for NUD-effect	V	1
DWQ	Effective channel width reduction for CV	m	0
EF	Flicker noise frequency exponent	–	1
EFO	Flicker noise frequency exponent	–	1
EPSROX	Relative permittivity of gate dielectric	–	3.9
EPSROX0	Relative permittivity of gate dielectric	–	3.9
FACNEFFAC	Pre-factor for effective substrate doping in separate charge calculation	–	1
FACNEFFACL	Length dependence of FACNEFFAC	–	0
FACNEFFACLW	Area dependence of FACNEFFAC	–	0
FACNEFFACO	Geom. independent pre-factor for effective substrate doping in separate charge calculation	–	1

Parameter	Description	Units	Default
FACNEFFACW	Width dependence of FACNEFFAC	–	0
FBOTRBTOT	Normalization field at the reference temperature for band-to-band tunneling of bottom component for source-bulk junction	–	1e+09
FBOTRBTOD	Normalization field at the reference temperature for band-to-band tunneling of bottom component for drain-bulk junction	–	1e+09
FBOTRGTOT	Normalization field at the reference temperature for band-to-band tunneling of gate-edge component for source-bulk junction	–	1e+09
FBOTRGTOD	Normalization field at the reference temperature for band-to-band tunneling of gate-edge component for drain-bulk junction	–	1e+09
FBOTRSTI	Normalization field at the reference temperature for band-to-band tunneling of STI-edge component for source-bulk junction	–	1e+09
FBOTRSTID	Normalization field at the reference temperature for band-to-band tunneling of STI-edge component for drain-bulk junction	–	1e+09
FBET1	Relative mobility decrease due to first lateral profile	–	0
FBET1W	Width dependence of relative mobility decrease due to first lateral profile	–	0
FBET2	Relative mobility decrease due to second lateral profile	–	0
FETA	Effective field parameter	–	1
FETAO	Effective field parameter	–	1
FJUNQ	Fraction below which source-bulk junction capacitance components are considered negligible	–	0.03
FJUNQD	Fraction below which drain-bulk junction capacitance components are considered negligible	–	0.03
FNT	Thermal noise coefficient	–	1
FNT0	Thermal noise coefficient	–	1
FOL1	First length dependence coefficient for short channel body effect	–	0
FOL2	Second length dependence coefficient for short channel body effect	–	0

Parameter	Description	Units	Default
GC2	Gate current slope factor	–	0.375
GC20	Gate current slope factor	–	0.375
GC3	Gate current curvature factor	–	0.063
GC30	Gate current curvature factor	–	0.063
GCO	Gate tunneling energy adjustment	–	0
GCO0	Gate tunneling energy adjustment	–	0
GFACNUD	Bodyfactor change due to NUD-effect	–	1
GFACNUDL	Length dependence of GFACNUD	–	0
GFACNUDLEXP	Exponent for length dependence of GFACNUD	–	1
GFACNUDLW	Area dependence of GFACNUD	–	0
GFACNUDO	Geom. independent bodyfactor change due to NUD-effect	–	1
GFACNUDW	Width dependence of GFACNUD	–	0
IDSATRBOT	Saturation current density at the reference temperature of bottom component for source-bulk junction	–	1e-12
IDSATRBOTD	Saturation current density at the reference temperature of bottom component for drain-bulk junction	–	1e-12
IDSATRGAT	Saturation current density at the reference temperature of gate-edge component for source-bulk junction	–	1e-18
IDSATRGATD	Saturation current density at the reference temperature of gate-edge component for drain-bulk junction	–	1e-18
IDSATRSTI	Saturation current density at the reference temperature of STI-edge component for source-bulk junction	–	1e-18
IDSATRSTID	Saturation current density at the reference temperature of STI-edge component for drain-bulk junction	–	1e-18
IGINV	Gate channel current pre-factor	A	0
IGINVLW	Gate channel current pre-factor for 1 um**2 channel area	A	0
IGOV	Gate overlap current pre-factor	A	0
IGOVD	Gate overlap current pre-factor for drain side	A	0
IGOVDW	Gate overlap current pre-factor for 1 um wide channel for drain side	A	0
IGOVW	Gate overlap current pre-factor for 1 um wide channel	A	0

Parameter	Description	Units	Default
IMAX	Maximum current up to which forward current behaves exponentially	–	1000
KUO	Mobility degradation/enhancement coefficient	m	0
KUOWEL	Length dependent mobility degradation factor	–	0
KUOWELW	Area dependent mobility degradation factor	–	0
KUOWEO	Geometrical independent mobility degradation factor	–	0
KUOWEW	Width dependent mobility degradation factor	–	0
KVSAT	Saturation velocity degradation/enhancement coefficient	m	0
KVTHO	Threshold shift parameter	Vm	0
KVTHOWEL	Length dependent threshold shift parameter	–	0
KVTHOWELW	Area dependent threshold shift parameter	–	0
KVTHOWEO	Geometrical independent threshold shift parameter	–	0
KVTHOWEW	Width dependent threshold shift parameter	–	0
LAP	Effective channel length reduction per side	m	0
LEVEL	Model level	–	103
LINTNOI	Length offset for flicker noise	m	0
LKUO	Length dependence of KUO	–	0
LKVTHO	Length dependence of KVTHO	–	0
LLODKUO	Length parameter for UO stress effect	–	0
LLODVTH	Length parameter for VTH-stress effect	–	0
LMAX	Dummy parameter to label binning set	m	1
LMIN	Dummy parameter to label binning set	m	0
LODETA0	eta0 shift modification factor for stress effect	–	1
LOV	Overlap length for gate/drain and gate/source overlap capacitance	m	0
LOVD	Overlap length for gate/drain overlap capacitance	m	0
LP1	Mobility-related characteristic length of first lateral profile	m	1e-08
LP1W	Width dependence of mobility-related characteristic length of first lateral profile	–	0
LP2	Mobility-related characteristic length of second lateral profile	m	1e-08

Parameter	Description	Units	Default
LPCK	Char. length of lateral doping profile	m	1e-08
LPCKW	Width dependence of char. length of lateral doping profile	–	0
LVARL	Length dependence of LVAR	–	0
LVARO	Geom. independent difference between actual and programmed gate length	m	0
LVARW	Width dependence of LVAR	–	0
MEFFTATBOT	Effective mass (in units of m0) for trap-assisted tunneling of bottom component for source-bulk junction	–	0.25
MEFFTATBOTD	Effective mass (in units of m0) for trap-assisted tunneling of bottom component for drain-bulk junction	–	0.25
MEFFTATGAT	Effective mass (in units of m0) for trap-assisted tunneling of gate-edge component for source-bulk junction	–	0.25
MEFFTATGATD	Effective mass (in units of m0) for trap-assisted tunneling of gate-edge component for drain-bulk junction	–	0.25
MEFFTATSTI	Effective mass (in units of m0) for trap-assisted tunneling of STI-edge component for source-bulk junction	–	0.25
MEFFTATSTID	Effective mass (in units of m0) for trap-assisted tunneling of STI-edge component for drain-bulk junction	–	0.25
MUE	Mobility reduction coefficient at TR	m/V	0.5
MUEO	Geometry independent mobility reduction coefficient at TR	m/V	0.5
MUEW	Width dependence of mobility reduction coefficient at TR	–	0
NEFF	Effective substrate doping	$m^{-3}$	5e+23
NFA	First coefficient of flicker noise	–	8e+22
NFALW	First coefficient of flicker noise for 1 $\mu m^2$ channel area	–	8e+22
NFB	Second coefficient of flicker noise	–	3e+07
NFBLW	Second coefficient of flicker noise for 1 $\mu m^2$ channel area	–	3e+07
NFC	Third coefficient of flicker noise	$V^{-1}$	0
NFCLW	Third coefficient of flicker noise for 1 $\mu m^2$ channel area	$V^{-1}$	0
NOV	Effective doping of overlap region	$m^{-3}$	5e+25
NOVD	Effective doping of overlap region for drain side	$m^{-3}$	5e+25

Parameter	Description	Units	Default
NOVDO	Effective doping of overlap region for drain side	$m^{-3}$	5e+25
NOVO	Effective doping of overlap region	$m^{-3}$	5e+25
NP	Gate poly-silicon doping	$m^{-3}$	1e+26
NPCK	Pocket doping level	$m^{-3}$	1e+24
NPCKW	Width dependence of pocket doping NPCK due to segregation	–	0
NPL	Length dependence of gate poly-silicon doping	–	0
NPO	Geometry-independent gate poly-silicon doping	$m^{-3}$	1e+26
NSLP	Effective doping bias-dependence parameter	V	0.05
NSLPO	Effective doping bias-dependence parameter	V	0.05
NSUBO	Geometry independent substrate doping	$m^{-3}$	3e+23
NSUBW	Width dependence of background doping NSUBO due to segregation	–	0
PBOT	Grading coefficient of bottom component for source-bulk junction	–	0.5
PBOTD	Grading coefficient of bottom component for drain-bulk junction	–	0.5
PBRBOT	Breakdown onset tuning parameter of bottom component for source-bulk junction	–	4
PBRBOTD	Breakdown onset tuning parameter of bottom component for drain-bulk junction	–	4
PBRGAT	Breakdown onset tuning parameter of gate-edge component for source-bulk junction	–	4
PBRGATD	Breakdown onset tuning parameter of gate-edge component for drain-bulk junction	–	4
PBRSTI	Breakdown onset tuning parameter of STI-edge component for source-bulk junction	–	4
PBRSTID	Breakdown onset tuning parameter of STI-edge component for drain-bulk junction	–	4
PGAT	Grading coefficient of gate-edge component for source-bulk junction	–	0.5
PGATD	Grading coefficient of gate-edge component for drain-bulk junction	–	0.5

Parameter	Description	Units	Default
PHIGBOT	Zero-temperature bandgap voltage of bottom component for source-bulk junction	–	1.16
PHIGBOTD	Zero-temperature bandgap voltage of bottom component for drain-bulk junction	–	1.16
PHIGGAT	Zero-temperature bandgap voltage of gate-edge component for source-bulk junction	–	1.16
PHIGGATD	Zero-temperature bandgap voltage of gate-edge component for drain-bulk junction	–	1.16
PHIGSTI	Zero-temperature bandgap voltage of STI-edge component for source-bulk junction	–	1.16
PHIGSTID	Zero-temperature bandgap voltage of STI-edge component for drain-bulk junction	–	1.16
PKUO	Cross-term dependence of KUO	–	0
PKVTHO	Cross-term dependence of KVTHO	–	0
PLA1	Coefficient for the length dependence of A1	–	0
PLA3	Coefficient for the length dependence of A3	–	0
PLA4	Coefficient for the length dependence of A4	–	0
PLAGIDL	Coefficient for the length dependence of AGIDL	A/V <sup>3</sup>	0
PLAGIDLD	Coefficient for the length dependence of AGIDL for drain side	A/V <sup>3</sup>	0
PLALP	Coefficient for the length dependence of ALP	–	0
PLALP1	Coefficient for the length dependence of ALP1	V	0
PLALP2	Coefficient for the length dependence of ALP2	–	0
PLAX	Coefficient for the length dependence of AX	–	0
PLBETN	Coefficient for the length dependence of BETN	–	0
PLCF	Coefficient for the length dependence of CF	–	0
PLCFR	Coefficient for the length dependence of CFR	F	0
PLCFRD	Coefficient for the length dependence of CFR for drain side	F	0
PLCGBOV	Coefficient for the length dependence of CGBOV	F	0
PLCGOV	Coefficient for the length dependence of CGOV	F	0
PLCGOVD	Coefficient for the length dependence of CGOV for drain side	F	0

Parameter	Description	Units	Default
PLCOX	Coefficient for the length dependence of COX	F	0
PLCS	Coefficient for the length dependence of CS	–	0
PLCT	Coefficient for the length dependence of CT	–	0
PLDELVTAC	Coefficient for the length dependence of DELVTAC	V	0
PLDPHIB	Coefficient for the length dependence of DPHIB	V	0
PLFACNEFFAC	Coefficient for the length dependence of FACNEFFAC	–	0
PLGFACNUD	Coefficient for the length dependence of GFACNUD	–	0
PLIGINV	Coefficient for the length dependence of IGINV	A	0
PLIGOV	Coefficient for the length dependence of IGOV	A	0
PLIGOVD	Coefficient for the length dependence of IGOV for drain side	A	0
PLKUOWE	Coefficient for the length dependence part of KUOWE	–	0
PLKVTHOWE	Coefficient for the length dependence part of KVTHOWE	–	0
PLMUE	Coefficient for the length dependence of MUE	–	0
PLNEFF	Coefficient for the length dependence of NEFF	m <sup>-3</sup>	0
PLNFA	Coefficient for the length dependence of NFA	–	0
PLNFB	Coefficient for the length dependence of NFB	–	0
PLNFC	Coefficient for the length dependence of NFC	–	0
PLNOV	Coefficient for the length dependence of NOV	m <sup>-3</sup>	0
PLNOVD	Coefficient for the length dependence of NOV for drain side	m <sup>-3</sup>	0
PLNP	Coefficient for the length dependence of NP	m <sup>-3</sup>	0
PLRS	Coefficient for the length dependence of RS	–	0
PLSTBET	Coefficient for the length dependence of STBET	–	0
PLSTTHESAT	Coefficient for the length dependence of STTHESAT	–	0
PLSTVFB	Coefficient for the length dependence of STVFB	V/K	0
PLTHESAT	Coefficient for the length dependence of THESAT	–	0
PLTHESATB	Coefficient for the length dependence of THESATB	–	0
PLTHESATG	Coefficient for the length dependence of THESATG	–	0
PLVFB	Coefficient for the length dependence of VFB	V	0
PLWA1	Coefficient for the length times width dependence of A1	–	0

Parameter	Description	Units	Default
PLWA3	Coefficient for the length times width dependence of A3	–	0
PLWA4	Coefficient for the length times width dependence of A4	–	0
PLWAGIDL	Coefficient for the length times width dependence of AGIDL	A/V <sup>3</sup>	0
PLWAGIDLD	Coefficient for the length times width dependence of AGIDL for drain side	A/V <sup>3</sup>	0
PLWALP	Coefficient for the length times width dependence of ALP	–	0
PLWALP1	Coefficient for the length times width dependence of ALP1	V	0
PLWALP2	Coefficient for the length times width dependence of ALP2	–	0
PLWAX	Coefficient for the length times width dependence of AX	–	0
PLWBETN	Coefficient for the length times width dependence of BETN	–	0
PLWCF	Coefficient for the length times width dependence of CF	–	0
PLWCFR	Coefficient for the length times width dependence of CFR	F	0
PLWCFRD	Coefficient for the length times width dependence of CFR for drain side	F	0
PLWCGBOV	Coefficient for the length times width dependence of CGBOV	F	0
PLWCGOV	Coefficient for the length times width dependence of CGOV	F	0
PLWCGOVD	Coefficient for the length times width dependence of CGOV for drain side	F	0
PLWCOX	Coefficient for the length times width dependence of COX	F	0
PLWCS	Coefficient for the length times width dependence of CS	–	0
PLWCT	Coefficient for the length times width dependence of CT	–	0
PLWDELVTAC	Coefficient for the length times width dependence of DELVTAC	V	0
PLWDPHIB	Coefficient for the length times width dependence of DPHIB	V	0

Parameter	Description	Units	Default
PLWFACNEFFAC	Coefficient for the length times width dependence of FACNEFFAC	–	0
PLWGFACNUD	Coefficient for the length times width dependence of GFACNUD	–	0
PLWIGINV	Coefficient for the length times width dependence of IGINV	A	0
PLWIGOV	Coefficient for the length times width dependence of IGOV	A	0
PLWIGOVD	Coefficient for the length times width dependence of IGOV for drain side	A	0
PLWKUOWE	Coefficient for the length times width dependence part of KUOWE	–	0
PLWKVTHOWE	Coefficient for the length times width dependence part of KVTHOWE	–	0
PLWMUE	Coefficient for the length times width dependence of MUE	–	0
PLWNEFF	Coefficient for the length times width dependence of NEFF	m <sup>-3</sup>	0
PLWNFA	Coefficient for the length times width dependence of NFA	–	0
PLWNFB	Coefficient for the length times width dependence of NFB	–	0
PLWNFC	Coefficient for the length times width dependence of NFC	–	0
PLWNOV	Coefficient for the length times width dependence of NOV	m <sup>-3</sup>	0
PLWNOVD	Coefficient for the length times width dependence of NOV for drain side	m <sup>-3</sup>	0
PLWNP	Coefficient for the length times width dependence of NP	m <sup>-3</sup>	0
PLWRS	Coefficient for the length times width dependence of RS	–	0
PLWSTBET	Coefficient for the length times width dependence of STBET	–	0
PLWSTTHESAT	Coefficient for the length times width dependence of STTHESAT	–	0

Parameter	Description	Units	Default
PLWSTVFB	Coefficient for the length times width dependence of STVFB	V/K	0
PLWTHESAT	Coefficient for the length times width dependence of THESAT	–	0
PLWTHESATB	Coefficient for the length times width dependence of THESATB	–	0
PLWTHESATG	Coefficient for the length times width dependence of THESATG	–	0
PLWVFB	Coefficient for the length times width dependence of VFB	V	0
PLWXCOR	Coefficient for the length times width dependence of XCOR	–	0
PLXCOR	Coefficient for the length dependence of XCOR	–	0
POA1	Coefficient for the geometry independent part of A1	–	1
POA2	Coefficient for the geometry independent part of A2	V	10
POA3	Coefficient for the geometry independent part of A3	–	1
POA4	Coefficient for the geometry independent part of A4	–	0
POAGIDL	Coefficient for the geometry independent part of AGIDL	A/V <sup>3</sup>	0
POAGIDLD	Coefficient for the geometry independent part of AGIDL for drain side	A/V <sup>3</sup>	0
POALP	Coefficient for the geometry independent part of ALP	–	0.01
POALP1	Coefficient for the geometry independent part of ALP1	V	0
POALP2	Coefficient for the geometry independent part of ALP2	–	0
POAX	Coefficient for the geometry independent part of AX	–	3
POBETN	Coefficient for the geometry independent part of BETN	–	0.07
POBGIDL	Coefficient for the geometry independent part of BGIDL	V	41
POBGIDLD	Coefficient for the geometry independent part of BGIDL for drain side	V	41
POCF	Coefficient for the geometry independent part of CF	–	0
POCFB	Coefficient for the geometry independent part of CFB	–	0
POCFR	Coefficient for the geometry independent part of CFR	F	0
POCFRD	Coefficient for the geometry independent part of CFR for drain side	F	0

Parameter	Description	Units	Default
POCGBOV	Coefficient for the geometry independent part of CGBOV	F	0
POCGIDL	Coefficient for the geometry independent part of CGIDL	–	0
POCGIDLD	Coefficient for the geometry independent part of CGIDL for drain side	–	0
POCGOV	Coefficient for the geometry independent part of CGOV	F	1e-15
POCGOVD	Coefficient for the geometry independent part of CGOV for drain side	F	1e-15
POCHIB	Coefficient for the geometry independent part of CHIB	V	3.1
POCOX	Coefficient for the geometry independent part of COX	F	1e-14
POCS	Coefficient for the geometry independent part of CS	–	0
POCT	Coefficient for the geometry independent part of CT	–	0
PODELVTAC	Coefficient for the geometry independent part of DELVTAC	V	0
PODNSUB	Coefficient for the geometry independent part of DNSUB	–	0
PODPHIB	Coefficient for the geometry independent part of DPHIB	V	0
PODVSENUD	Coefficient for the geometry independent part of DVSENUD	V	1
POEF	Coefficient for the flicker noise frequency exponent	–	1
POEPSROX	Coefficient for the geometry independent part of EPSOX	–	3.9
POFACNEFFAC	Coefficient for the geometry independent part of FACNEFFAC	–	1
POFETA	Coefficient for the geometry independent part of FETA	–	1
POFNT	Coefficient for the geometry independent part of FNT	–	1
POGC2	Coefficient for the geometry independent part of GC2	–	0.375
POGC3	Coefficient for the geometry independent part of GC3	–	0.063
POGCO	Coefficient for the geometry independent part of GCO	–	0
POGFACNUD	Coefficient for the geometry independent part of GFACNUD	–	1
POIGINV	Coefficient for the geometry independent part of IGINV	A	0
POIGOV	Coefficient for the geometry independent part of IGOV	A	0
POIGOVD	Coefficient for the geometry independent part of IGOV for drain side	A	0

Parameter	Description	Units	Default
POKUOWE	Coefficient for the geometry independent part of KUOWE	–	0
POKVTHOWE	Coefficient for the geometry independent part of KVTHOWE	–	0
POMUE	Coefficient for the geometry independent part of MUE	–	0.5
PONEFF	Coefficient for the geometry independent part of NEFF	m <sup>-3</sup>	5e+23
PONFA	Coefficient for the geometry independent part of NFA	–	8e+22
PONFB	Coefficient for the geometry independent part of NFB	–	3e+07
PONFC	Coefficient for the geometry independent part of NFC	–	0
PONOV	Coefficient for the geometry independent part of NOV	m <sup>-3</sup>	5e+25
PONOVD	Coefficient for the geometry independent part of NOV for drain side	m <sup>-3</sup>	5e+25
PONP	Coefficient for the geometry independent part of NP	m <sup>-3</sup>	1e+26
PONSLP	Coefficient for the geometry independent part of NSLP	V	0.05
PORS	Coefficient for the geometry independent part of RS	–	30
PORSB	Coefficient for the geometry independent part of RSB	–	0
PORSG	Coefficient for the geometry independent part of RSG	–	0
POSTA2	Coefficient for the geometry independent part of STA2	V	0
POSTBET	Coefficient for the geometry independent part of STBET	–	1
POSTBGIDL	Coefficient for the geometry independent part of STBGIDL	V/K	0
POSTBGIDLD	Coefficient for the geometry independent part of STBGIDL for drain side	V/K	0
POSTCS	Coefficient for the geometry independent part of STCS	–	0
POSTIG	Coefficient for the geometry independent part of STIG	–	2
POSTMUE	Coefficient for the geometry independent part of STMUE	–	0
POSTRS	Coefficient for the geometry independent part of STRS	–	1
POSTTHEMU	Coefficient for the geometry independent part of STTHEMU	–	1.5
POSTTHESAT	Coefficient for the geometry independent part of STTHESAT	–	1
POSTVFB	Coefficient for the geometry independent part of STVFB	V/K	0.0005

Parameter	Description	Units	Default
POSTXCOR	Coefficient for the geometry independent part of STXCOR	–	0
POTHEMU	Coefficient for the geometry independent part of THEMU	–	1.5
POTHEMAT	Coefficient for the geometry independent part of THEMAT	–	1
POTHEMATB	Coefficient for the geometry independent part of THEMATB	–	0
POTHEMATG	Coefficient for the geometry independent part of THEMATG	–	0
POTOX	Coefficient for the geometry independent part of TOX	m	2e-09
POTOXOV	Coefficient for the geometry independent part of TOXOV	m	2e-09
POTOXOVD	Coefficient for the geometry independent part of TOXOV for drain side	m	2e-09
POVFB	Coefficient for the geometry independent part of VFB	V	-1
POVNSUB	Coefficient for the geometry independent part of VNSUB	V	0
POVP	Coefficient for the geometry independent part of VP	V	0.05
POVSBNUD	Coefficient for the geometry independent part of VSBNUD	V	0
POXCOR	Coefficient for the geometry independent part of XCOR	–	0
PSTI	Grading coefficient of STI-edge component for source-bulk junction	–	0.5
PSTID	Grading coefficient of STI-edge component for drain-bulk junction	–	0.5
PWA1	Coefficient for the width dependence of A1	–	0
PWA3	Coefficient for the width dependence of A3	–	0
PWA4	Coefficient for the width dependence of A4	–	0
PWAGIDL	Coefficient for the width dependence of AGIDL	A/V <sup>3</sup>	0
PWAGIDLD	Coefficient for the width dependence of AGIDL for drain side	A/V <sup>3</sup>	0
PWALP	Coefficient for the width dependence of ALP	–	0
PWALP1	Coefficient for the width dependence of ALP1	V	0
PWALP2	Coefficient for the width dependence of ALP2	–	0
PWAX	Coefficient for the width dependence of AX	–	0

Parameter	Description	Units	Default
PWBETN	Coefficient for the width dependence of BETN	–	0
PWCF	Coefficient for the width dependence of CF	–	0
PWCFR	Coefficient for the width dependence of CFR	F	0
PWCFRD	Coefficient for the width dependence of CFR for drain side	F	0
PWCGBOV	Coefficient for the width dependence of CGBOV	F	0
PWCGOV	Coefficient for the width dependence of CGOV	F	0
PWCGOVD	Coefficient for the width dependence of CGOV for drain side	F	0
PWCOX	Coefficient for the width dependence of COX	F	0
PWCS	Coefficient for the width dependence of CS	–	0
PWCT	Coefficient for the width dependence of CT	–	0
PWDELVTAC	Coefficient for the width dependence of DELVTAC	V	0
PWDPHIB	Coefficient for the width dependence of DPHIB	V	0
PWFACNEFFAC	Coefficient for the width dependence of FACNEFFAC	–	0
PWGFACTUD	Coefficient for the width dependence of GFACNUD	–	0
PWIGINV	Coefficient for the width dependence of IGINV	A	0
PWIGOV	Coefficient for the width dependence of IGOV	A	0
PWIGOVD	Coefficient for the width dependence of IGOV for drain side	A	0
PWKUOWE	Coefficient for the width dependence part of KUOWE	–	0
PWKVTHOWE	Coefficient for the width dependence part of KVTHOWE	–	0
PWMUE	Coefficient for the width dependence of MUE	–	0
PWNEFF	Coefficient for the width dependence of NEFF	$m^{-3}$	0
PWNFA	Coefficient for the width dependence of NFA	–	0
PWNFB	Coefficient for the width dependence of NFB	–	0
PWNFC	Coefficient for the width dependence of NFC	–	0
PWNOV	Coefficient for the width dependence of NOV	$m^{-3}$	0
PWNOVD	Coefficient for the width dependence of NOV for drain side	$m^{-3}$	0
PWNP	Coefficient for the width dependence of NP	$m^{-3}$	0

Parameter	Description	Units	Default
PWRS	Coefficient for the width dependence of RS	–	0
PWSTBET	Coefficient for the width dependence of STBET	–	0
PWSTTHESAT	Coefficient for the width dependence of STTHESAT	–	0
PWSTVFB	Coefficient for the width dependence of STVFB	V/K	0
PWTHESAT	Coefficient for the width dependence of THESAT	–	0
PWTHESATB	Coefficient for the width dependence of THESATB	–	0
PWTHESATG	Coefficient for the width dependence of THESATG	–	0
PWVFB	Coefficient for the width dependence of VFB	V	0
PWXCOR	Coefficient for the width dependence of XCOR	–	0
QMC	Quantum-mechanical correction factor	–	1
RBULK	Bulk resistance between node BP and BI	$\Omega$	0
RBULK0	Bulk resistance between node BP and BI	$\Omega$	0
RDE	External drain resistance	$\Omega$	0
RG	Gate resistance	$\Omega$	0
RG0	Gate resistance	$\Omega$	0
RINT	Contact resistance between silicide and ploy	$\Omega - m^2$	0
RJUND	Drain-side bulk resistance between node BI and BD	$\Omega$	0
RJUNDO	Drain-side bulk resistance between node BI and BD	$\Omega$	0
RJUNS	Source-side bulk resistance between node BI and BS	$\Omega$	0
RJUNSO	Source-side bulk resistance between node BI and BS	$\Omega$	0
RS	Series resistance at TR	$\Omega$	30
RSB	Back-bias dependence of series resistance	$V^{-1}$	0
RSB0	Back-bias dependence of series resistance	$V^{-1}$	0
RSE	External source resistance	$\Omega$	0
RSG	Gate-bias dependence of series resistance	$V^{-1}$	0
RSG0	Gate-bias dependence of series resistance	$V^{-1}$	0
RSH	Sheet resistance of source diffusion	ohm/square	0
RSHD	Sheet resistance of drain diffusion	ohm/square	0
RSHG	Gate electrode diffusion sheet resistance	ohm/square	0

Parameter	Description	Units	Default
RSW1	Source/drain series resistance for 1 um wide channel at TR	$\Omega$	50
RSW2	Higher-order width scaling of RS	–	0
RVPOLY	Vertical poly resistance	$\Omega - m^2$	0
RWELL	Well resistance between node BI and B	$\Omega$	0
RWELLO	Well resistance between node BI and B	$\Omega$	0
SAREF	Reference distance between OD-edge and poly from one side	m	1e-06
SBREF	Reference distance between OD-edge and poly from other side	m	1e-06
SCREF	Distance between OD-edge and well edge of a reference device	m	1e-06
STA2	Temperature dependence of A2	V	0
STA20	Temperature dependence of A2	V	0
STBET	Temperature dependence of BETN	–	1
STBETL	Length dependence of temperature dependence of BETN	–	0
STBETLW	Area dependence of temperature dependence of BETN	–	0
STBETO	Geometry independent temperature dependence of BETN	–	1
STBETW	Width dependence of temperature dependence of BETN	–	0
STBGIDL	Temperature dependence of BGIDL	V/K	0
STBGIDLD	Temperature dependence of BGIDL for drain side	V/K	0
STBGIDLDO	Temperature dependence of BGIDL for drain side	V/K	0
STBGIDL0	Temperature dependence of BGIDL	V/K	0
STCS	Temperature dependence of CS	–	0
STCS0	Temperature dependence of CS	–	0
STETA0	eta0 shift factor related to VTHO change	m	0
STFBBTBOT	Temperature scaling parameter for band-to-band tunneling of bottom component for source-bulk junction	–	-0.001
STFBBTBOTD	Temperature scaling parameter for band-to-band tunneling of bottom component for drain-bulk junction	–	-0.001

Parameter	Description	Units	Default
STFBBTGAT	Temperature scaling parameter for band-to-band tunneling of gate-edge component for source-bulk junction	–	-0.001
STFBBTGATD	Temperature scaling parameter for band-to-band tunneling of gate-edge component for drain-bulk junction	–	-0.001
STFBBTSTI	Temperature scaling parameter for band-to-band tunneling of STI-edge component for source-bulk junction	–	-0.001
STFBBTSTID	Temperature scaling parameter for band-to-band tunneling of STI-edge component for drain-bulk junction	–	-0.001
STIG	Temperature dependence of IGINV and IGOV	–	2
STIGO	Temperature dependence of IGINV and IGOV	–	2
STMUE	Temperature dependence of MUE	–	0
STMUEO	Temperature dependence of MUE	–	0
STRS	Temperature dependence of RS	–	1
STRSO	Temperature dependence of RS	–	1
STTHEMU	Temperature dependence of THEMU	–	1.5
STTHEMUO	Temperature dependence of THEMU	–	1.5
STTHESAT	Temperature dependence of THESAT	–	1
STTHESATL	Length dependence of temperature dependence of THESAT	–	0
STTHESATLW	Area dependence of temperature dependence of THESAT	–	0
STTHESATO	Geometry independent temperature dependence of THESAT	–	1
STTHESATW	Width dependence of temperature dependence of THESAT	–	0
STVFB	Temperature dependence of VFB	V/K	0.0005
STVFBL	Length dependence of temperature dependence of VFB	V/K	0
STVFBLW	Area dependence of temperature dependence of VFB	V/K	0
STVFBO	Geometry-independent temperature dependence of VFB	V/K	0.0005
STVFBW	Width dependence of temperature dependence of VFB	V/K	0

Parameter	Description	Units	Default
STXCOR	Temperature dependence of XCOR	–	0
STXCORO	Temperature dependence of XCOR	–	0
SWDELVTAC	Flag for separate capacitance calculation; 0=off, 1=on	–	0
SWGEO	Flag for geometrical model, 0=local, 1=global, 2=binning	–	1
SWGIDL	Flag for GIDL current, 0=turn off IGIDL	–	0
SWGATE	Flag for gate current, 0=turn off IG	–	0
SWIMPACT	Flag for impact ionization current, 0=turn off II	–	0
SWJUNASYM	Flag for asymmetric junctions; 0=symmetric, 1=asymmetric	–	0
SWJUNCAP	Flag for juncap, 0=turn off juncap	–	0
SWJUNEXP	Flag for JUNCAP-express; 0=full model, 1=express model	–	0
SWNUD	Flag for NUD-effect; 0=off, 1=on, 2=on+CV-correction	–	0
THEMU	Mobility reduction exponent at TR	–	1.5
THEMUO	Mobility reduction exponent at TR	–	1.5
THESAT	Velocity saturation parameter at TR	$V^{-1}$	1
THESATB	Back-bias dependence of velocity saturation	$V^{-1}$	0
THESATBO	Back-bias dependence of velocity saturation	$V^{-1}$	0
THESATG	Gate-bias dependence of velocity saturation	$V^{-1}$	0
THESATGO	Gate-bias dependence of velocity saturation	$V^{-1}$	0
THESATL	Length dependence of THESAT	$V^{-1}$	0.05
THESATLEXP	Exponent for length dependence of THESAT	–	1
THESATLW	Area dependence of velocity saturation parameter	–	0
THESATO	Geometry independent velocity saturation parameter at TR	$V^{-1}$	0
THESATW	Width dependence of velocity saturation parameter	–	0
TKUO	Temperature dependence of KUO	–	0
TOX	Gate oxide thickness	m	2e-09
TOXO	Gate oxide thickness	m	2e-09
TOXOV	Overlap oxide thickness	m	2e-09
TOXOVD	Overlap oxide thickness for drain side	m	2e-09

Parameter	Description	Units	Default
TOXOVDO	Overlap oxide thickness for drain side	m	2e-09
TOXOVO	Overlap oxide thickness	m	2e-09
TR	nominal (reference) temperature	°C	21
TRJ	reference temperature	–	21
TYPE	Channel type parameter, +1=NMOS -1=PMOS	–	1
U0	Zero-field mobility at TR	m <sup>2</sup> /(Vs)	0.05
VBIRBOT	Built-in voltage at the reference temperature of bottom component for source-bulk junction	–	1
VBIRBOTD	Built-in voltage at the reference temperature of bottom component for drain-bulk junction	–	1
VBIRGAT	Built-in voltage at the reference temperature of gate-edge component for source-bulk junction	–	1
VBIRGATD	Built-in voltage at the reference temperature of gate-edge component for drain-bulk junction	–	1
VBIRSTI	Built-in voltage at the reference temperature of STI-edge component for source-bulk junction	–	1
VBIRSTID	Built-in voltage at the reference temperature of STI-edge component for drain-bulk junction	–	1
VBRBOT	Breakdown voltage of bottom component for source-bulk junction	–	10
VBRBOTD	Breakdown voltage of bottom component for drain-bulk junction	–	10
VBRGAT	Breakdown voltage of gate-edge component for source-bulk junction	–	10
VBRGATD	Breakdown voltage of gate-edge component for drain-bulk junction	–	10
VBRSTI	Breakdown voltage of STI-edge component for source-bulk junction	–	10
VBRSTID	Breakdown voltage of STI-edge component for drain-bulk junction	–	10
VFB	Flat band voltage at TR	V	-1
VFBL	Length dependence of flat-band voltage	V	0
VFBLW	Area dependence of flat-band voltage	V	0
VFBO	Geometry-independent flat-band voltage at TR	V	-1

Parameter	Description	Units	Default
VFBW	Width dependence of flat-band voltage	V	0
VJUNREF	Typical maximum source-bulk junction voltage; usually about 2*VSUP	–	2.5
VJUNREFD	Typical maximum drain-bulk junction voltage; usually about 2*VSUP	–	2.5
VNSUB	Effective doping bias-dependence parameter	V	0
VNSUBO	Effective doping bias-dependence parameter	V	0
VP	CLM logarithm dependence factor	V	0.05
VPO	CLM logarithmic dependence parameter	V	0.05
VSBNUD	Lower Vsb value for NUD-effect	V	0
VSBNUDO	Lower Vsb value for NUD-effect	V	0
WBET	Characteristic width for width scaling of BETN	m	1e-09
WEB	Coefficient for SCB	–	0
WEC	Coefficient for SCC	–	0
WKUO	Width dependence of KUO	–	0
WKVTHO	Width dependence of KVTHO	–	0
WLOD	Width parameter	m	0
WLODKUO	Width parameter for UO stress effect	–	0
WLODVTH	Width parameter for VTH-stress effect	–	0
WMAX	Dummy parameter to label binning set	m	1
WMIN	Dummy parameter to label binning set	m	0
WOT	Effective channel width reduction per side	m	0
WSEG	Char. length of segregation of background doping NSUBO	m	1e-08
WSEGP	Char. length of segregation of pocket doping NPCK	m	1e-08
WVARL	Length dependence of WVAR	–	0
WVARO	Geom. independent difference between actual and programmed field-oxide opening	m	0
WVARW	Width dependence of WVAR	–	0
XCOR	Non-universality factor	V <sup>-1</sup>	0
XCORL	Length dependence of non-universality parameter	–	0

Parameter	Description	Units	Default
XCORLW	Area dependence of non-universality parameter	–	0
XCORO	Geometry independent non-universality parameter	$V^{-1}$	0
XCORW	Width dependence of non-universality parameter	–	0
XJUNGAT	Junction depth of gate-edge component for source-bulk junction	–	1e-07
XJUNGATD	Junction depth of gate-edge component for drain-bulk junction	–	1e-07
XJUNSTI	Junction depth of STI-edge component for source-bulk junction	–	1e-07
XJUNSTID	Junction depth of STI-edge component for drain-bulk junction	–	1e-07

Table 2.37: PSP103VA MOSFET Device Model Parameters.

#### Model level 301 (EKV version 3.0.1)

As of Release 5.2, **Xyce** includes the EKV MOSFET model, version 3.0.1 [15][16][17], the EKV3 model. Full documentation for the EKV3 model is available on the **Xyce** web site, <http://xyce.sandia.gov>; the documentation for the EKV3 model available there may be freely redistributed. Instance and model parameters for the EKV model are given in tables 2.38 and 2.39.

The EKV3 model is developed by the EKV Team of the Electronics Laboratory-TUC (Technical University of Crete). It is included in **Xyce** under license from Technical University of Crete. The official web site of the EKV model is <http://ekv.epfl.ch/>.

Parameter	Description	Units	Default
AD	DRAIN'S AREA	–	0
AS	SOURCE'S AREA	–	0
L	GATE'S LENGTH	–	1e-05
M	NUMBER OF DEVICES IN PARALLEL	–	1
NF	NUMBER OF FINGERS	–	1
PD	DRAIN'S PERIMETER	–	0
PS	SOURCE'S PERIMETER	–	0
SA	STI PARAMETER; DISTANCE FROM STI	–	0

Parameter	Description	Units	Default
SB	STI PARAMETER; DISTANCE FROM STI	–	0
SD	STI PARAMETER; DISTANCE BETWEEN GATES	–	0
W	GATE'S WIDTH	–	1e-05

Table 2.38: EKV3 MOSFET Device Instance Parameters.

Parameter	Description	Units	Default
ACLM		–	0.83
AF		–	1
AGAM		–	0
AGAMMA	MATCHING PARAMETER FOR BODY FACTOR (GAMMA)	–	0
AGIDL		–	0
AKP	MATCHING PARAMETER FOR MOBILITY (KP)	–	0
AQMA		–	0.5
AQMI		–	0.4
AVT		–	0
AVTO	MATCHING PARAMETER FOR THRESHOLD VOLTAGE (VTO)	–	0
BEX		–	-1.5
BGIDL		–	2.3e+09
BVD		–	10
BVS		–	10
CGBO		–	0
CGDO		–	0
CGIDL		–	0.5
CGSO		–	0
CJD		–	0
CJF		–	0
CJS		–	0
CJSWD		–	0
CJSWGD		–	0

Parameter	Description	Units	Default
CJSWGS		–	0
CJSWS		–	0
COX		–	0.012
DDITS		–	0.3
DELTA		–	2
DFR		–	0.001
DGAMMAEDGE		–	0
DL		–	-1e-08
DLC		–	0
DPHIEDGE		–	0
DW		–	-1e-08
DWC		–	0
E0		–	1e+10
E1		–	3.1e+08
EB		–	2.9e+10
EF		–	2
EGIDL		–	0.8
ETA		–	0.5
ETAD		–	1
ETAQM		–	0.75
FLR		–	0
FPROUT		–	1e+06
GAMMA		–	0.3
GAMMAG		–	4.1
GAMMAGOV		–	10
GAMMAOV		–	1.6
GC		–	1
GMIN		–	0
HDIF		–	0
IBA		–	0

Parameter	Description	Units	Default
IBB		–	3e+08
IBBT		–	0.0008
IBN		–	1
INFO_LEVEL		–	0
JSD		–	0
JSS		–	0
JSSWD		–	0
JSSWGD		–	0
JSSWGS		–	0
JSSWS		–	0
JTSD		–	0
JTSS		–	0
JTSSWD		–	0
JTSSWGD		–	0
JTSSWGS		–	0
JTSSWS		–	0
KA		–	0
KB		–	0
KETAD		–	0
KF		–	0
KG		–	0
KGAMMA		–	0
KGFN		–	0
KJF		–	0
KKP		–	0
KP		–	0.0005
KRGL1		–	0
KUCRIT		–	0
KVTO		–	0
LA		–	1

Parameter	Description	Units	Default
LAMBDA		–	0.5
LB		–	1
LDIF		–	0
LDPHIEDGE		–	0
LDW		–	0
LETA		–	0.5
LETA0		–	0
LETA2		–	0
LGAM		–	1
LKKP		–	0
LKVTO		–	0
LL		–	0
LLN		–	1
LLODKKP		–	1
LLODKVTO		–	1
LNWR		–	0
LODKETAD		–	1
LODKGAMMA		–	1
LOV		–	2e-08
LOVIG		–	2e-08
LQWR		–	0
LR		–	5e-08
LVT		–	1
LWR		–	0
MJD		–	0.9
MJS		–	0.9
MJSWD		–	0.7
MJSWGD		–	0.7
MJSWGS		–	0.7
MJSWS		–	0.7

Parameter	Description	Units	Default
NO		–	1
NCS		–	1
NFVTA		–	0
NFVTB		–	10000
NJD		–	1
NJS		–	1
NJTSD		–	1
NJTSS		–	1
NJTSSWD		–	1
NJTSSWGD		–	1
NJTSSWGS		–	1
NJTSSWS		–	1
NLR		–	0.01
NQS_NOI		–	1
NWR		–	0.005
PBD		–	0.8
PBS		–	0.8
PBSWD		–	0.6
PBSWGD		–	0.6
PBSWGS		–	0.6
PBSWS		–	0.6
PDITS		–	0
PDITSD		–	1
PDITSL		–	0
PHIF	FERMI BULK POTENTIAL	–	0.45
PKKP		–	0
PKVTO		–	0
QLR		–	0.0005
QOFF		–	0
QWR		–	0.0003

Parameter	Description	Units	Default
RBN		—	0
RBWSH		—	0.003
RD		—	0
RDBN		—	0
RDBWSH		—	0.001
RDSBSH		—	1000
RDX		—	-1
RGSH		—	3
RINGTYPE		—	1
RLX	EXTERNAL SERIES RESISTANCE	—	-1
RS		—	0
RSBN		—	0
RSBWSH		—	0.001
RSH		—	0
RSX		—	-1
SAREF		—	0
SBREF		—	0
SCALE		—	1
SIGMAD		—	1
SIGN	SIGN = 1 FOR NMOS; SIGN = -1 FOR PMOS	—	1
TCJ		—	0
TCJSW		—	0
TCJSWG		—	0
TCV		—	0.0006
TCVL		—	0
TCVW		—	0
TCVWL		—	0
TEOEX		—	0.5
TE1EX		—	0.5
TETA		—	-0.0009

Parameter	Description	Units	Default
TG	TYPE OF GATE: -1 ENHANCEMENT TYPE; 1 DEPLETION TYPE	–	-1
THC		–	0
TH_NOI		–	0
TKKP		–	0
TLAMBDA		–	0
TNJTSD		–	0
TNJTSS		–	0
TNJTSSWD		–	0
TNJTSSWGD		–	0
TNJTSSWGS		–	0
TNJTSSWS		–	0
TNOM		–	-246.15
TPB		–	0
TPBSW		–	0
TPBSWG		–	0
TR		–	0
TR2		–	0
UCEX		–	1.5
UCRIT		–	5e+06
VBI		–	0
VFBOV		–	0
VFR		–	0
VOV		–	1
VT0	THRESHOLD VOLTAGE	–	0.3
VTSD		–	0
VTSS		–	0
VTSSWD		–	0
VTSSWGD		–	0
VTSSWGS		–	0

Parameter	Description	Units	Default
VTSSWS		–	0
WDL		–	0
WDPHIEDGE		–	0
WEO		–	0
WE1		–	0
WEDGE		–	0
WETA		–	0.2
WETAD		–	0
WGAM		–	1
WKKP		–	0
WKP1		–	1e-06
WKP2		–	0
WKP3		–	1
WKVTO		–	0
WLAMBDA		–	0
WLDGAMMAEDGE		–	0
WLDPHIEDGE		–	0
WLOD		–	0
WLODKKP		–	1
WLODKVTO		–	1
WLR		–	0
WNLR		–	0
WQLR		–	0
WR		–	9e-08
WRLX		–	0
WUCEX		–	0
WUCRIT		–	0
WVT		–	1
XB		–	3.1
XJ		–	2e-08

Parameter	Description	Units	Default
XJBVD		–	0
XJBVS		–	0
XL		–	0
XTID		–	3
XTIS		–	3
XTSD		–	0
XTSS		–	0
XTSSWD		–	0
XTSSWGD		–	0
XTSSWGS		–	0
XTSSWS		–	0
XW		–	0
ZC		–	1e-06

Table 2.39: EKV3 MOSFET Device Model Parameters.

## Quadratic Temperature Compensation

Spice temperature effects are default, but MOSFET levels 18, 19 and 20 have a more advanced temperature compensation available. By specifying `TEMPMODEL=QUADRATIC` in the netlist, parameters can be interpolated quadratically between measured values extracted from data. See Section 5.3 of the User's Guide for more details.

## MOSFET Equations

The following equations define an N-channel MOSFET. The P-channel devices use a reverse the sign for all voltages and currents. The equations use the following variables:

$$\begin{aligned}
 V_{bs} &= \text{intrinsic substrate-intrinsic source voltage} \\
 V_{bd} &= \text{intrinsic substrate-intrinsic drain voltage} \\
 V_{ds} &= \text{intrinsic drain-substrate source voltage} \\
 V_{dsat} &= \text{saturation voltage} \\
 V_{gs} &= \text{intrinsic gate-intrinsic source voltage} \\
 V_{gd} &= \text{intrinsic gate-intrinsic drain voltage} \\
 V_t &= kT/q \text{ (thermal voltage)}
 \end{aligned}$$

$V_{th}$	=	threshold voltage
$C_{ox}$	=	the gate oxide capacitance per unit area
$f$	=	noise frequency
$k$	=	Boltzmann's constant
$q$	=	electron charge
$L_{eff}$	=	effective channel length
$W_{eff}$	=	effective channel width
$T$	=	analysis temperature ( $^{\circ}K$ )
$T_0$	=	nominal temperature (set using TNOM option)

Other variables are listed in the BJT Model Parameters Table 2.20.

## All Levels

$$I_g = \text{gate current} = 0$$

$$I_b = \text{bulk current} = I_{bs} + I_{bd}$$

where

$$I_{bs} = \text{bulk-source leakage current} = I_{ss} \left( e^{V_{bs}/(NV_t)} - 1 \right)$$

$$I_{ds} = \text{bulk-drain leakage current} = I_{ds} \left( e^{V_{bd}/(NV_t)} - 1 \right)$$

where

if

$$\mathbf{JS} = 0, \text{ or } \mathbf{AS} = 0 \text{ or } \mathbf{AD} = 0$$

then

$$I_{ss} = \mathbf{IS}$$

$$I_{ds} = \mathbf{IS}$$

else

$$I_{ss} = \mathbf{AS} \times \mathbf{JS} + \mathbf{PS} \times \mathbf{JSSW}$$

$$I_{ds} = \mathbf{AD} \times \mathbf{JS} + \mathbf{PD} \times \mathbf{JSSW}$$

$$I_d = \text{drain current} = I_{drain} - I_{bd}$$

$$I_s = \text{source current} = -I_{drain} - I_{bs}$$

## Level 1: Idrain

**Normal Mode:**  $V_{ds} > 0$

**Case 1**

For cutoff region:  $V_{gs} - V_{to} < 0$

$$I_{drain} = 0$$

**Case 2**

For linear region:  $V_{ds} < V_{gs} - V_{to}$

$$I_{drain} = (W/L)(KN/2)(1 + LAMBDA \times V_{ds})V_{ds}(2(V_{gs} - V_{to}) - V_{ds})$$

**Case 3**

For saturation region:  $0 \leq V_{gs} - V_{to} \leq V_{ds}$

$$I_{drain} = (W/L)(KN/2)(1 + LAMBDA \cdot V_{ds})(V_{gs} - V_{to})^2$$

where

$$V_{to} = VTO + GAMMA \cdot \left( (PHI - V_{bs})^{1/2} \right)^{1/2}$$

**Inverted Mode:**  $V_{ds} < 0$

Here, simply switch the source and drain in the normal mode equations given above.

**Level 3: Idrain**

See Reference [18] below for detailed information.

## Capacitance

**Level 1 and 3**

$C_{bs}$  = bulk-source capacitance = area cap. + sidewall cap. + transit time cap.

$C_{bd}$  = bulk-drain capacitance = area cap. + sidewall cap. + transit time cap.

where

*if*

$$\mathbf{CBS} = 0 \text{ and } \mathbf{CBD} = 0$$

*then*

$$C_{bs} = \mathbf{AS} \cdot \mathbf{CJ} \cdot C_{bsj} + \mathbf{PS} \cdot \mathbf{CJSW} \cdot C_{bss} + \mathbf{TT} \cdot G_{bs}$$

$$C_{bd} = \mathbf{AD} \cdot \mathbf{CJ} \cdot C_{bdj} + \mathbf{PD} \cdot \mathbf{CJSW} \cdot C_{bds} + \mathbf{TT} \cdot G_{ds}$$

*else*

$$C_{bs} = \mathbf{CBS} \cdot C_{bsj} + \mathbf{PS} \cdot \mathbf{CJSW} \cdot C_{bss} + \mathbf{TT} \cdot G_{bs}$$

$$C_{bd} = \mathbf{CBD} \cdot C_{bdj} + \mathbf{PD} \cdot \mathbf{CJSW} \cdot C_{bds} + \mathbf{TT} \cdot G_{ds}$$

*where*

$$G_{bs} = \text{DC bulk-source conductance} = dI_{bs}/dV_{bs}$$

$$G_{bd} = \text{DC bulk-drain conductance} = dI_{bd}/dV_{bd}$$

*if*

$$V_{bs} \leq \mathbf{FC} \cdot \mathbf{PB}$$

*then*

$$C_{bsj} = (1 - V_{bs}/\mathbf{PB})^{-\mathbf{MJ}}$$

$$C_{bss} = (1 - V_{bs}/\mathbf{PBSW})^{-\mathbf{MJSW}}$$

*if*

$$V_{bs} > \mathbf{FC} \cdot \mathbf{PB}$$

*then*

$$C_{bsj} = (1 - \mathbf{FC})^{-(1+\mathbf{MJ})} (1 - \mathbf{FC}(1 + \mathbf{MJ}) + \mathbf{MJ} \cdot V_{bs}/\mathbf{PB})$$

$$C_{bss} = (1 - \mathbf{FC})^{-(1+\mathbf{MJSW})} (1 - \mathbf{FC}(1 + \mathbf{MJSW}) + \mathbf{MJSW} \cdot V_{bs}/\mathbf{PBSW})$$

*if*

$$V_{bd} \leq \mathbf{FC} \cdot \mathbf{PB}$$

*then*

$$C_{bdj} = (1 - V_{bd}/\mathbf{PB})^{-\mathbf{MJ}}$$

$$C_{bds} = (1 - V_{bd}/\mathbf{PBSW})^{-\mathbf{MJSW}}$$

*if*

$$V_{bd} > \mathbf{FC} \cdot \mathbf{PB}$$

*then*

$$C_{bdj} = (1 - \mathbf{FC})^{-(1+\mathbf{MJ})} (1 - \mathbf{FC}(1 + \mathbf{MJ}) + \mathbf{MJ} \cdot V_{bd}/\mathbf{PB})$$

$$C_{bds} = (1 - \mathbf{FC})^{-(1+\mathbf{MJSW})} (1 - \mathbf{FC}(1 + \mathbf{MJSW}))$$

$$C_{gs} = \text{gate-source overlap capacitance} = \mathbf{CGSO} \cdot \mathbf{W}$$

$$C_{gd} = \text{gate-drain overlap capacitance} = \mathbf{CGDO} \cdot \mathbf{W}$$

$$C_{gb} = \text{gate-bulk overlap capacitance} = \mathbf{CGBO} \cdot \mathbf{L}$$

## Temperature Effects

### All Levels

$$\mathbf{IS}(T) = \mathbf{IS} \cdot \exp(E_g(T_0) \cdot T/T_0 - E_g(T)) / V_t$$

$$\mathbf{JS}(T) = \mathbf{JS} \cdot \exp(E_g(T_0) \cdot T/T_0 - E_g(T)) / V_t$$

$$\mathbf{JSSW}(T) = \mathbf{JSSW} \cdot \exp(E_g(T_0) \cdot T/T_0 - E_g(T)) / V_t$$

$$\mathbf{PB}(T) = \mathbf{PB} \cdot T/T_0 - 3V_t \ln(T/T_0) - E_g(T_0) \cdot T/T_0 + E_g T$$

$$\mathbf{PBSW}(T) = \mathbf{PBSW} \cdot T/T_0 - 3V_t \ln(T/T_0) - E_g(T_0) \cdot T/T_0 + E_g T$$

$$\mathbf{PHI}(T) = \mathbf{PHI} \cdot T/T_0 - 3V_t \ln(T/T_0) - E_g(T_0) \cdot T/T_0 + E_g T$$

where

$$E_g(T) = \text{silicon bandgap energy} = 1.16 - 0.000702T^2/(T + 1108)$$

$$\mathbf{CBD}(T) = \mathbf{CBD} \cdot (1 + \mathbf{MJ} \cdot (0.0004(T - T_0) + (1 - \mathbf{PB}(T)/\mathbf{PB})))$$

$$\mathbf{CBS}(T) = \mathbf{CBS} \cdot (1 + \mathbf{MJ} \cdot (0.0004(T - T_0) + (1 - \mathbf{PB}(T)/\mathbf{PB})))$$

$$\mathbf{CJ}(T) = \mathbf{CJ} \cdot (1 + \mathbf{MJ} \cdot (0.0004(T - T_0) + (1 - \mathbf{PB}(T)/\mathbf{PB})))$$

$$\mathbf{CJSW}(T) = \mathbf{CJSW} \cdot (1 + \mathbf{MJSW} \cdot (0.0004(T - T_0) + (1 - \mathbf{PB}(T)/\mathbf{PB})))$$

$$\mathbf{KP}(T) = \mathbf{KP} \cdot (T/T_0)^{-3/2}$$

$$\mathbf{UO}(T) = \mathbf{UO} \cdot (T/T_0)^{-3/2}$$

$$\mathbf{MUS}(T) = \mathbf{MUS} \cdot (T/T_0)^{-3/2}$$

$$\mathbf{MUZ}(T) = \mathbf{MUZ} \cdot (T/T_0)^{-3/2}$$

$$\mathbf{X3MS}(T) = \mathbf{X3MS} \cdot (T/T_0)^{-3/2}$$

For a thorough description of MOSFET models see [19, 18, 20, 21, 22, 9, 10, 23, 24, 15].

For complete documentation of the BSIM3 model, see the users' manual for the BSIM3, available for download at <http://www-device.eecs.berkeley.edu/~bsim3/get.html>. Xyce implements Version 3.2.2 of the BSIM3, you will have to get the documentation from the FTP archive on the Berkeley site.

For complete documentation of the BSIMSOI model, see the users' manual for the BSIMSOI, available for download at <http://www-device.eecs.berkeley.edu/~bsimsoi/>. Xyce implements Version 3.2 of the BSIMSOI, you will have to get the documentation from the FTP archive on the Berkeley site.

For complete documentation of the BSIM4 model, see the users' manual for the BSIM4,

available for download at <http://www-device.eecs.berkeley.edu/~bsim3/bsim4.html>. **Xyce** implements Version 4.6.1 of the BIMS4, you will have to get the documentation from the FTP archive on the Berkeley site.

## Voltage- or Current-controlled Switch

---

**General Form**      S<name> <(+) switch node> <(-) switch node>  
                         + <(+) control node> <(-) control node>  
                         + <model name> [ON] [OFF]

                         W<name> <(+) switch node> <(-) switch node>  
                         + <control node voltage source>  
                         + <model name> [ON] [OFF]

---

**Examples**

```
S1 21 23 12 10 SMOD1
SSET 15 10 1 13 SRELAY
W1 1 2 VCLOCK SWITCHMOD1
W2 3 0 VRAMP SM1 ON
```

---

**Model Form**      .MODEL <model name> VSWITCH [model parameters]  
                         .MODEL <model name> ISWITCH [model parameters]

---

**Description**      The voltage- or current-controlled switch is a particular type of controlled resistor. This model is designed to help reduce numerical issues. See Special considerations below.

---

---

The resistance between the <(+) switch node> and the <(-) switch node> is dependent on either the voltage between the <(+) control node> and the <(-) control node> or the current through the control node voltage source. The resistance changes in a continuous manner between the **RON** and **ROFF** model parameters.

No resistance is inserted between the control nodes. It is up to the user to make sure that these nodes are not floating.

### Comments

Even though evaluating the switch model is computationally inexpensive, for transient analysis, **Xyce** steps through the transition section using small time-steps in order to calculate the waveform accurately. Thus, a circuit with many switch transitions can result in lengthy run times.

The **ON** and **OFF** parameters are used to specify the initial state of the switch at the first step of the operating point calculation; this does not force the switch to be in that state, it only gives the operating point solver an initial state to work with. If it is known that the switch should be in a particular state in the operating point it could help convergence to specify one of these keywords.

---

## Model Parameters

Table 2.40 gives the available model parameters for the voltage- or current-controlled switch.

## Special Considerations

- Due to numerical limitations, **Xyce** can only manage a dynamic range of approximately 12 decades. Thus, it is recommended the user limit the ratio **ROFF/RON** to less than  $10^{12}$ .
- Furthermore, it is a good idea to limit the narrowness of the transition region. This is because in the transition region, the switch has gain and the narrower the region, the higher the gain and the more potential for numerical problems. The smallest value allowed for  $\|VON - VOFF\|$  or  $\|ION - IOFF\|$  is  $1 \times 10^{-12}$ .

Model parameters	Description	Units	Default
ROFF	Off Resistance	ohm	$1.0 \times 10^6$
RON	On Resistance	ohm	1.0
VOFF	Control Voltage for Off State	volt	0.0
VON	Control Voltage for On State	volt	1.0
IOFF	Control Current for Off State	amp	0.0
ION	Control Current for On State	amp	$1 \times 10^{-3}$
OFF	Control for Off State		
ON	Control for On State		

**Table 2.40.** Controlled Switch Model Parameters.

### Controlled switch equations

The equations in this section use the following variables:

- $R_s$  = switch resistance
- $V_c$  = voltage across control nodes
- $I_c$  = current through control node voltage source
- $L_m$  = log-mean of resistor values =  $\ln(\sqrt{\mathbf{RON} \cdot \mathbf{ROFF}})$
- $L_r$  = log - ratio of resistor values =  $\ln(\mathbf{RON}/\mathbf{ROFF})$
- $V_d$  = difference of control voltages =  $\mathbf{VON} - \mathbf{VOFF}$
- $I_d$  = difference of control currents =  $\mathbf{ION} - \mathbf{IOFF}$

#### Switch Resistance

To compute the switch resistance, **Xyce** first calculates the “switch state”  $S$  as  $S = (V_c - \mathbf{VOFF})/V_d$  or  $S = (I_c - \mathbf{IOFF})/I_d$ . The switch resistance is then:

$$R_s = \begin{cases} \mathbf{RON}, & S \geq 1.0 \\ \mathbf{ROFF}, & S \leq 0.0 \\ \exp(L_m + 0.75L_r(2S - 1) - 0.25L_r(2S - 1)^3), & 0 < S < 1 \end{cases}$$

## Generic Switch

---

**General Form** SW<name> <(+) switch node> <(-) switch node>  
 + <model name> [ON] [OFF] <control = { expression }>

---

**Examples**

```
SW 1 2 SWI OFF CONTROL={I(VMON)}
SW 1 2 SWV OFF CONTROL={V(3)-V(4)}
SW 1 2 SW OFF CONTROL={if(time>0.001,1,0)}
```

---

**Model Form**

```
.MODEL <model name> VSWITCH [model parameters]
.MODEL <model name> ISWITCH [model parameters]
.MODEL <model name> SWITCH [model parameters]
```

---

**Description**

The generic switch is similar to the voltage- or current-controlled switch except that the control variable is anything that can be written as an expression. The examples show how a voltage- or current-controlled switch can be implemented with the generic switch. Also shown is a relay that turns on when a certain time is reached. Model parameters are given in Table 2.40.

---

## Lossless (Ideal) Transmission Line

	T<name> <A port (+) node> <A port (-) node>
<b>General Form</b>	+ <B port (+) node> <B port (-) node> [model name] + Z0=<value> [TD=<value>] [F=<value> [NL=<value>]]
<b>Examples</b>	Tline inp inn outp outn Z0=50 TD=1us Tline2 inp inn outp outn Z0=50 F=1meg NL=1.0
<b>Symbol</b>	
<b>Description</b>	The lossless transmission line device is a two port (A and B), bi-directional delay line. The (+) and (-) nodes define the polarity of a positive voltage at a port.
<b>Comments</b>	Z0 is the characteristic impedance. The transmission line's length is specified by either TD (a delay in seconds) or by F and NL (a frequency and relative wavelength at F). NL defaults to 0.25 (F is the quarter-wave frequency). If F is given, the time delay is computed as $\frac{NL}{F}$ . While both TD and F are optional, at least one of them must be given.

### Model Parameters

Table 2.41 gives the available model parameters for the lossless transmission line.

Model parameters	Description	Units	Default
Z0	Characteristic impedance	ohm	-
TD	Transmission delay	second	-
F	Frequency for <b>NL</b>	Hz	-
NL	Relative wavelength	-	0.25

**Table 2.41.** Lossless (Ideal) Transmission Line Parameters.

## Behavioral Digital Devices

---

**General Form**    Y<type> <name> [low output node] [high output node]  
                          [input reference node] <input node(s)> <output node(s)>  
                          <model name> [device parameters]

---

**Examples**

```

YAND MYAND in1 in2 out DMOD IC=1
YNOT THENOT in out DMOD
YNOR ANOR2 vlo vhi vref in1 in2 out DDEF
.model DMOD DIG (
+ CLO=1e-12 CHI=1e-12
+ SORLO=5 SORHI=5 SOTSW=5e-9
+ SOVLO=-1 SOVHI=1.8
+ S1RLO=200 S1RHI=5 S1TSW=5e-9
+ S1VLO=1 S1VHI=3
+ RLOAD=1000
+ CLOAD=1e-12
+ VREF=0 VLO=0 VHI=3
+ DELAY=20ns )
.MODEL DDEF DIG

```

---

**Model Form**    .MODEL <model name> DIG [model parameters]

---

---

<type>

Type of digital device. Supported devices are: NOT, AND, NAND, OR, NOR, XOR, NXOR, and ADD. All have two input nodes and one output node, except NOT, which has only one input node and 1 output and ADD which has 3 input and two output.

<name>

Name of the device instance. This must be present, and when combined with the Y<type>, must be unique in the netlist. In the examples, MYAND, THENOT and ANOR2 have been used as names for the three devices.

[low output node]

Dominant node to be connected to the output node(s) to establish low output state. This node is connected to the output by a resistor and capacitor in parallel, whose values are set by the model. If specified by the model, this node can be omitted and a fixed voltage is used instead.

[high output node]

Dominant node to be connected to the output node(s) to establish high output state. This node is connected to the output by a resistor and capacitor in parallel, whose values are set by the model. If specified by the model, this node can be omitted and a fixed voltage is used instead.

[input reference node]

This node is connected to the input node by a resistor and capacitor in parallel, whose values are set by the model. Determination if the input state is based on the voltage drop between the input node and this node. If specified by the model, this node can be omitted and a fixed voltage is used instead.

<input and output nodes>

Nodes that connect to the circuit.

<model name>

Name of the model defined in a .MODEL line.

## **Parameters and Options**

[device parameters]

### Parameters and Options

Parameter listed in Table 2.42 may be provided as <parameter>=<value> specifications as needed. For devices with more than one output, multiple output initial states may be provided as a comma separated list (e.g. IC=T,F).

## Device Parameters

Table 2.42 gives the available device parameters for the behavioral digital devices.

Parameter	Description	Units	Default
IC	Vector of initial values for output(s)	logical (T/F)	False

Table 2.42: Behavioral Digital Device Parameters.

## Model Parameters

Table 2.43 gives the available model parameters for the behavioral digital devices.

Parameter	Description	Units	Default
CHI	Capacitance between output node and high reference	F	1e-06
CLO	Capacitance between output node and low reference	F	1e-06
CLOAD	Capacitance between input node and input reference	F	1e-06
DELAY	Delay time of device	s	1e-08
RLOAD	Resistance between input node and input reference	$\Omega$	1000
SORHI	Low state resistance between output node and high reference	$\Omega$	100
SORLO	Low state resistance between output node and low reference	$\Omega$	100
SOTSW	Switching time transition to low state	s	1e-08
SOVHI	Maximum voltage to switch to low state	V	1.7
SOVLO	Minimum voltage to switch to low state	V	-1.5
S1RHI	High state resistance between output node and high reference	$\Omega$	100

Parameter	Description	Units	Default
S1RLO	High state resistance between output node and low reference	$\Omega$	100
S1TSW	Switching time transition to high state	s	1e-08
S1VHI	Maximum voltage to switch to high state	V	7
S1VLO	Minimum voltage to switch to high state	V	0.9
VHI	Internal high state supply voltage	V	0
VLO	Internal low state supply voltage	V	0
VREF	Internal reference voltage for inputs	V	0

Table 2.43: Behavioral Digital Model Parameters.

## Model Description

The input interface model consists of the input node connected with a resistor and capacitor in parallel to the input reference node. The values of these are: RLOAD and CLOAD. If the model parameter VREF is specified, then the input reference node is not given, and an internal node of fixed voltage, VREF, is used instead.

The logical state of any input node is determined by comparing the voltage relative to the reference to the range for the low and high state. The range for the low state is S0VLO to S0VHI. Similarly, the range for the high state is S1VLO to S1VHI. The state of the input node will remain fixed as long as the voltage stays within the range for the current state. Only when it goes outside the range will transition to the other state be considered.

The output interface model is more complex than the input model, but shares the same basic configuration of a resistor and capacitor in parallel to simulate loading. For the output case, there are such connections to two nodes, the low output node and the high output node. Either or both of these can be omitted if the VLO and/or VHI model parameters are specified. Specifying either of these causes a fixed voltage node to be used in place of an externally connected node, like in the input case.

The capacitance to the high node is specified by CHI, and the capacitance to the low node is CLO. The resistors in parallel with these capacitors are variable, and have values that depend on the state. In the low state (S0), the resistance values are: S0RLO and S0RHI. In the high state (S1), the resistance values are: S1RLO and S1RHI. Transition to the high state occurs exponentially over a time of S1TSW, and to the low state S0TSW.

Delay of the device is given by the model parameter DELAY.

## Accelerated mass

Simulation of electromechanical devices or magnetically driven machines may require that **Xyce** simulate the movement of an accelerated mass, that is, to solve the second order initial value problem

$$\begin{aligned}\frac{d^2x}{dt^2} &= a(t) \\ x(0) &= x_0 \\ \dot{x}_0 &= v_0\end{aligned}$$

where  $x$  is the position of the object,  $\dot{x}$  its velocity, and  $a(t)$  the acceleration. As of **Xyce** Release 4.1, this simulation capability is provided by the accelerated mass device.

---

### **General Form**

YACC <name> <acceleration node> <velocity node> <position node>  
+ [v0=<initial velocity>] [x0=<initial position>]

---

### **Examples**

```
*Simulate a projectile thrown upward against gravity
V1 acc 0 -9.8
R1 acc 0 1
YACC acc1 acc vel pos v0=10 x0=0
.print tran v(pos)
.tran 1u 10s
.end

*simulate a damped, forced harmonic oscillator
* assuming K, c, mass, amplitude and frequency defined in
.param statements
B1 acc 0 V={(-K*v(pos)-c*v(vel))/mass+amplitude*sin(frequency*TIME)}

R1 acc 0 1
YACC acc2 acc vel pos v0=0 x0=.4
.print tran v(pos)
.tran 1u 10s
.end
```

---

### **Comments**

When used as in the examples, **Xyce** will emit warning messages about the `pos` and `vel` nodes not having a DC path to ground. This is normal and should be ignored. In future versions of **Xyce** this warning will not be printed, as the condition it warns of is inconsequential in this instance. The position and velocity nodes should not be connected to any real circuit elements. Their values may, however, be used in behavioral sources; this is done in the second example.

---

## Subcircuit

A subcircuit can be introduced into the circuit netlist using the specified nodes to substitute for the argument nodes in the definition. It provides a building block of circuitry to be defined a single time and subsequently used multiple times in the overall circuit netlists.

---

**General Form**    X<name> [node]\* <subcircuit name> [PARAMS: [<name> = <value>]\*]

---

**Examples**

```
X12 100 101 200 201 DIFFAMP
XBUFF 13 15 UNITAMP
XFOLLOW IN OUT VCC VEE OUT OPAMP
XFELT 1 2 FILTER PARAMS: CENTER=200kHz
XNANDI 25 28 7 MYPWR MYGND PARAMS: IO_LEVEL=2
```

**Parameters and Options**

---

<subcircuit name>  
     The name of the subcircuit's definition.

PARAMS:  
     Passed into subcircuits as arguments and into expressions inside the subcircuit.

---

**Comments**

There must be an equal number of nodes in the subcircuit call and in its definition.

Subcircuit references may be nested to any level. However, the nesting cannot be circular. For example, if subcircuit A's definition includes a call to subcircuit B, then subcircuit B's definition cannot include a call to subcircuit A.

---

## 2.3 TCAD Devices

Semiconductor device simulation, which is based on a coupled set of partial differential equations (PDE's) is supported in **Xyce**. Such devices can be invoked from the circuit netlist, in a similar manner to traditional SPICE-style analog devices. One dimensional and two dimensional devices are supported, with the dimensionality determined by the device model level.

---

**General Form, 1D:**

```
YPDE <name> <node> [node] [model name]
[na=<value>] [nd=<value>] [nx=<value>] [area=<value>]
[graded=<value>] [wj=<value>] [l=<value>] [w=<value>]
[tecplotlevel=<value>] [sgplotlevel=<value>]
[gnuplotlevel=<value>] [node=<tabular data>]
[region=<tabular data>] [bulkmaterial=<string>]
[temp=<value>]
```

---

**General Form, 2D:**

```
YPDE <name> <node> <node> [node][node] [model name]
[na=<value>] [nd=<value>] [meshfile=<filename.msh>]
[nx=<value>] [ny=<value>] [l=<value>] [w=<value>]
[type=<string>] [node=<tabular data>]
[region=<tabular data>] [x0=<value>] [cyl=<value>]
[tecplotlevel=<value>] [sgplotlevel=<value>]
[gnuplotlevel=<value>] [txtdatalevel=<value>]
[ph.a1=<value>] [ph.type=<string>]
[ph.tstart=<value>] [ph.tstop=<value>] [photogen=<value>]
[ph.td=<value>] [ph.tr=<value>]
[ph.tf=<value>] [ph.pw=<value>] [ph.per=<value>]
[bulkmaterial=<string>] [temp=<value>]
```

---

**Comments:** Most of the PDE parameters are specified on the instance level. At this point the model statement is only used for specifying if the device is 1D or 2D, via the level parameter. Both the 1D and the 2D devices can construct evenly spaced meshes, internally. The 2D device also has the option of reading in an unstructured mesh from an external mesh file.

The electrode tabular data specification is explained in detail in table 2.48. Similarly, the doping region tabular data specification is explained in detail in table 2.46.

---

## TCAD Device Parameters

Most TCAD device parameters are specified on the instance level.

Instance parameters	Description	Units	Default	Device Type
<i>All Levels</i>				
name	The instance name must start with a Z.	-	-	1D, 2D
node	Minimum of 2 connecting circuit nodes. The 2D device may have as many as 4 nodes, while the 1D device can only have 2. The node parameter is a tabular parameter, which specifies all the electrode attributes. See table 2.48 for a list.	-	-	1D, 2D
region	Specifies doping regions. Like the node parameter, this is a tabular parameter, containing several attributes.. See table 2.46 for a list.	-	-	1D, 2D
area	Cross sectional area of the device.	-	1.0	1D, 2D
tecplotlevel	Setting for Tecplot output: 0 - no Tecplot files 1 - Tecplot files, each output in a separate file. 2 - Tecplot file, each output appended to a single file. Tecplot files will have the .dat suffix, and the prefix will be the name of the device instance	-	1	1D, 2D
sgplotlevel	Flag for sgplot output. 0 - no sgplot files. 1 - sgplot files. sgplot is a plotting program that comes as part of the SG Framework [25]. sgplot files will have the *.res suffix, and the prefix will be the name of the device instance	-	0	1D, 2D

Instance parameters	Description	Units	Default	Device Type
gnuplotlevel	Flag for gnuplot output. 0 - no gnuplot files. 1 - gnuplot files. gnuplot is an open source plotting program that is usually installed on Linux systems. gnuplot files will have the *Gnu.dat suffix, and the prefix will be the name of the device instance.	-	0	1D, 2D
txtdatalevel	Flag for volume-averaged text output. 0 - no text files. 1 - text files. txtdataplot files will have the *.txt suffix, and the prefix will be the name of the device instance.	-	0	2D
bulkmaterial	Material of bulk material.	-	si	1D, 2D
mobmodel	mobility model.	-	carr	1D, 2D
type	P-type or N-type - this is only relevant if using the default dopings	-	PNP	1D, 2D
temp	Temperature	K	300.15	1D, 2D
nx	Number of mesh points, x-direction.	-	11	1D, 2D
l, w	Device length and width. These parameters mean the same thing for the 1D device.	-	1.0e-3	1D,2D
graded	Flag for graded junction vs. abrupt junction. (1=graded, 0=abrupt)	-	0	1D
wj	Junction width.	-	1.0e-4	1D
<b><i>Level 2 (2D) only</i></b>				
ny	Number of mesh points, y-direction. Similar to nx (see above).	-	11	2D

Instance parameters	Description	Units	Default	Device Type
meshfile	<p>This is a required field for a 2D simulation. If the user specifies <code>meshfile = internal.mesh</code>, then <b>Xyce</b> will create a cartesian mesh.</p> <p>If the user specifies anything else (for example <code>meshfile = diode.msh</code>), <b>Xyce</b> will attempt to read in an external mesh file (in the example, named <code>diode.msh</code>) which is in the format of the SG Framework [25].</p>	-	-	2D
x0	<p>This is the scaling factor for length. The code will do all of its scaling internally, so it is generally not necessary to specify it manually. This is provided primarily for testing purposes.</p>	-	max length of device	2D

Table 2.44: PDE Device Instance Parameters.



There is only one TCAD device model parameter, the level.

Model parameters	Description	Units	Default
LEVEL	The level determines if this is a 1D or a 2D device. 1=1D, 2=2D.	-	1

Table 2.45. TCAD Device Model Parameters.

Instance parameters	Description	Units	Default	Device Type
<i>All Levels</i>				
function	functional form of doping region. Options are uniform, gaussian, and step.		1D,2D	uniform
type	Ntype or Ptype		1D,2D	ntype
nmax	Maximum value of impurity concentration.	cm <sup>-3</sup>	1D,2D	1.0e15
nmin	Minimum value of impurity concentration.	cm <sup>-3</sup>	1D,2D	1.0e15
xloc	Peak location	cm	1D,2D	0.0
xwidth	Distance from nmax to nmin, if applicable. This is only applicable for the function=gaussian case.		1D,2D	1.0e-3
flatx	This parameter determines if we're doing a half gaussian or a full gaussian. See table 2.47	-	1D,2D	0
<i>Level 2 (2D) only</i>				
yloc	Same as xloc, but for the y-direction.	cm	2D	0.0
ywidth	Same as xwidth, but for the y-direction.	cm	2D	1.0e-3
flaty	Same as flatx, but for the y-direction.	-	2D	0

Table 2.46: PDE Device Doping Region Parameters. These correspond to the region instance parameter.

flatx or flaty value	Description	1D Cross Section
0	Gaussian on both sides of the peak (xloc) location.	
+1	Gaussian if x>xloc, flat (constant at the peak value) if x<xloc.	

flatx or flaty value	Description	1D Cross Section
-1	Gaussian if $x < x_{loc}$ , flat (constant at the peak value) if $x > x_{loc}$ .	

Table 2.47: Description of the flatx, flaty doping parameters

Electrode parameters	Description	Units	Default
<i>Level 2 (2D) only</i>			
name	Electrode name	-	anode
bc	Carrier Density Boundary condition type (dirichlet or neumann)	-	dirichlet
start	Starting location	cm	0.0
end	Ending location	cm	0.0
side	Side specification (top, bottom, left or right)	-	top
material	Contact material		neutral
oxidebndryflag	Oxide layer boolean	-	false (0)
oxthick	Oxide thickness	cm	0.0
oxcharge	Oxide charge	C	0.0

Table 2.48: PDE Device Electrode Parameters.

## Physical Models

This section contains information about physical models used in **Xyce** for TCAD devices. This includes various mobility models, expressions for calculating the effective mass for electrons and holes, an expression for intrinsic carrier concentration as a function of temperature, expressions which describe contacts to metal as well as contacts to metal-oxide-semiconductor devices.

### Material Models and Parameters

This section describes some of the basic material properties that are available in **Xyce**. Described here are the models for effective mass, intrinsic carrier concentration, and the bandgap. This information is needed for the more complex models described in the mobility section (section 2.3) and the boundary condition section (section 2.3).

### Effective Mass

**Xyce** includes functions which return the effective mass of electrons and holes for a number of semiconductor materials.

#### Electron Effective Mass

The electron effective mass is calculated as

$$m_{de} = (m_l^* m_t^{*2})^{1/3} \quad (2.4)$$

where  $m_l$  and  $m_t$  are the effective masses along the longitudinal and transverse directions of the ellipsoidal energy surface.

#### Hole Effective Mass

The hole effective mass is calculated as

$$m_{dh} = (m_{lh}^{*3/2} + m_{hh}^{*3/2})^{2/3} \quad (2.5)$$

where  $m_{lh}$  and  $m_{hh}$  are the "light" and "heavy" hole masses, respectively.

### Intrinsic Carrier Concentration

The intrinsic carrier concentration in a semiconductor is obtained from the "np" product

$$np = n_i^2 = N_C N_V \exp(-E_g/kT) \tag{2.6}$$

or

$$n_i = \sqrt{N_C N_V} e^{-E_g/2kT} \tag{2.7}$$

The expression used in **Xyce** to calculate the intrinsic carrier concentration comes from this and is given by

$$n_i = 4.9 \times 10^{15} \left( \frac{m_{de} m_{dh}}{m_0^2} \right)^{3/4} M_c^{1/2} T^{3/2} e^{-E_g/2kT} \tag{2.8}$$

where  $M_c$  is the number of equivalent minima in the conduction band for the semiconductor,  $m_{de}$  is the density-of-state effective mass for electrons,  $m_{dh}$  is the density-of-state effective mass for holes, and  $m_0$  is the free-electron mass.

Semiconductor	Symbol	$M_c^{1/2}$	$n_i$ at room temperature
Silicon	si	$\sqrt{6.00}$	$1.25 \times 10^{10}$
Germanium	ge	2.00	$2.5 \times 10^{13}$
Galium Arsenide	gaas	1.00	$2.0 \times 10^6$

Table 2.49: Intrinsic Carrier Concentration Parameters

### Bandgap

The bandgap is a material and temperature-dependent quantity. The bandgap model for semiconductor materials, is based on Thurmond [26]. This model is given by:

$$E_g = E_{g0} - A * \left( \frac{T^{2.0}}{T + T_{off}} \right) \tag{2.9}$$

where  $E_g$  is the bandgap (eV) and  $T$  is the temperature (K).  $A$ ,  $E_{g0}$ , and  $T_{off}$  are all

material-dependent constants. Insulating materials, such as silicon dioxide, are assumed to have constant bandgaps, so their bandgaps are given by:

$$E_g = E_{g0} \quad (2.10)$$

where  $E_{g0}$  is a material-dependent constant. The values for the material-dependent constants used by equations 2.9 and 2.10 are given in Table 2.50.

Material	Symbol	$E_{g0}$ (eV)	$A$	$T_{off}$ (K)
Silicon	si	1.17	4.73e-4	636.0
Germanium	ge	0.7437	4.774e-4	235.0
Galium Arsenide	gaas	1.519	5.405e-4	204.0
Silicon Dioxide	sio2	9.00	NA	NA
Silicon Nitride	wdi	4.7	NA	NA
Sapphire	cu	4.7	NA	NA

Table 2.50: Bandgap constants

## Mobility Models

A number of mobility models are included in **Xyce**. The analytic, arora, and carrier-carrier scattering models are considered to be low-field mobility models. The Lombardi surface mobility model is a transverse-field dependent model which also incorporates the mobility of the bulk silicon.

### Analytic Mobility

This is a concentration- and temperature-dependent empirical mobility model, based on the work of Caughey and Thomas [27], which combines the effects of lattice scattering and ionized impurity scattering. The equation for the mobility of electrons is:

$$\mu_{0n} = \mu_{nmin} + \frac{\mu_{nmax} \left(\frac{T}{T_{ref}}\right)^{nun} - \mu_{nmin}}{1 + \left(\frac{T}{T_{ref}}\right)^{xin} (N_{total}/N_n^{ref})^{\alpha_n}} \quad (2.11)$$

and the equation for the mobility of holes is:

$$\mu_{0p} = \mu_{pmin} + \frac{\mu_{pmax} \left(\frac{T}{T_{ref}}\right)^{nup} - \mu_{pmin}}{1 + \left(\frac{T}{T_{ref}}\right)^{xip} (N_{total}/N_p^{ref})^{\alpha_p}} \quad (2.12)$$

where  $N_{total}$  is the local total impurity concentration (in  $\#/cm^3$ ),  $T_{ref}$  is a reference temperature (300.15K), and T is the temperature (in degrees K). The parameters  $N_n^{ref}$  and  $N_p^{ref}$  are reference values for the doping concentration. The analytic mobility model can be selected by using the statement "mobmodel=analytic" in the netlist.

The parameters for the analytic mobility model are given in Table 3.

Parameter	Silicon	GaAs
$\mu_{nmin}$	55.24	0.0
$\mu_{nmax}$	1429.23	8500.0
$N_n^{ref}$	1.072e17	1.69e17
nun	-2.3	-1.0
xin	-3.8	0.0
$\alpha_n$	0.73	0.436
$\mu_{pmin}$	49.70	0.0
$\mu_{pmax}$	479.37	400.0
$N_p^{ref}$	1.606e17	2.75e17
nup	-2.2	-2.1
xip	-3.7	0.0
$\alpha_p$	0.70	0.395

Table 2.51: Analytic Mobility Parameters

### Arora Mobility

This mobility model is also an analytic model which depends on impurity concentration and temperature. It comes from the work of Arora, *et al.* [28] and is based on both experimental data and the modified Brooks-Herring theory of mobility. The equation for the mobility of electrons is:

$$\mu_{0n} = \mu_{n1} \left( \frac{T}{T_{ref}} \right)^{exp1} + \frac{\mu_{n2} \left( \frac{T}{T_{ref}} \right)^{exp2}}{1 + \left( \frac{N_{total}}{C_n \left( \frac{T}{T_{ref}} \right)^{exp3}} \right)^{\alpha_n}} \quad (2.13)$$

and the equation for the mobility of holes is:

$$\mu_{0p} = \mu_{p1} \left( \frac{T}{T_{ref}} \right)^{exp1} + \frac{\mu_{p2} \left( \frac{T}{T_{ref}} \right)^{exp2}}{1 + \left( \frac{N_{total}}{C_p \left( \frac{T}{T_{ref}} \right)^{exp3}} \right)^{\alpha_p}} \quad (2.14)$$

where

$$\alpha_n = A_n \left( \frac{T}{T_{ref}} \right)^{exn4} \tag{2.15}$$

and

$$\alpha_p = A_p \left( \frac{T}{T_{ref}} \right)^{exp4} \tag{2.16}$$

The Arora mobility model can be selected by including the statement "mobmodel=arora" in the netlist. The parameters for the arora mobility model are given in Table 4.

Parameter	Silicon	GaAs
$\mu_{n1}$	88.0	8.5e3
$\mu_{n2}$	1252.0	0.0
Cn	1.26e17	1.26e17
An	0.88	0.0
exn1	-0.57	-0.57
exn2	-2.33	0.0
exn3	2.4	0.0
exn4	-0.146	0.0
$\mu_{p1}$	54.3	4e2
$\mu_{p2}$	407.0	0.0
Cp	2.35e17	2.35e17
Ap	0.88	0.0
exp1	-0.57	0.0
exp2	-2.23	0.0
exp3	2.4	0.0
exp4	-0.146	0.0

Table 2.52: Arora Mobility Parameters

### Carrier-Carrier Scattering Mobility

This mobility model is based on the work of Dorkel and Leturq [29]. It incorporates carrier-carrier scattering effects, which are important when high concentrations of electrons and

holes are present in the device. This model also takes lattice scattering and ionized impurity scattering into account. One important difference between the carrier-carrier scattering mobility model and the two previous mobility models (analytic and arora models) is that the carrier-carrier scattering mobility model depends upon the actual carrier concentrations in the device. This model is important for modeling breakdown as well as various radiation effects, which often result in very high carrier densities.

The expressions for the carrier-carrier model are as follows:

$$\mu_L = \mu_{L0} \left( \frac{T}{T_{ref}} \right)^{-\alpha} \quad (2.17)$$

where  $\mu_L$  is the lattice mobility, which has to do with scattering due to acoustic phonons.

$$\mu_I = \frac{AT^{3/2}}{N} \left[ \ln \left( 1 + \frac{BT^2}{N} \right) - \frac{BT^2}{N + BT^2} \right]^{-1} \quad (2.18)$$

where  $\mu_I$  is the impurity mobility which is related to the interactions between the carriers and the ionized impurities.

$$\mu_{ccs} = \frac{2 \times 10^{17} T^{3/2}}{\sqrt{pn}} \left[ \ln \left( 1 + 8.28 \times 10^8 T^2 (pn)^{-1/3} \right) \right]^{-1} \quad (2.19)$$

where  $\mu_{ccs}$  is the carrier-carrier scattering mobility, which is very important when both types of carriers are at high concentration.

$$X = \sqrt{\frac{6\mu_L(\mu_I + \mu_{ccs})}{\mu_I\mu_{ccs}}} \quad (2.20)$$

is an intermediate term and

$$\mu = \mu_L \left[ \frac{1.025}{1 + (X/1.68)^{1.43}} - 0.025 \right] \quad (2.21)$$

is the carrier mobility. The carrier-carrier scattering mobility can be selected by including the statement "mobmodel=carr" in the netlist. The parameters for the carrier-carrier mobility model are given in Table 5.

Parameter	Carrier	Silicon	GaAs
Al	$e^-$	1430.0	8.50e3
Bl	$e^-$	-2.2	0.0
Ai	$e^-$	4.61e17	4.61e17
Bi	$e^-$	1.52e15	1.52e15
Al	$h^+$	495.0	4.0e2
Bl	$h^+$	-2.2	0.0
Ai	$h^+$	1.00e17	1.00e17
Bi	$h^+$	6.25e14	6.25e14

Table 2.53: Carrier-Carrier Mobility Parameters

### Lombardi Surface Mobility Model

This mobility model combines expressions for mobility at the semiconductor-oxide interface and in bulk silicon. It is based on the work of Lombardi *et al.* [30]. The overall mobility is found using Mathiessen’s rule:

$$\frac{1}{\mu} = \frac{1}{\mu_{ac}} + \frac{1}{\mu_b} + \frac{1}{\mu_{sr}} \tag{2.22}$$

where  $\mu_{ac}$  is the carrier mobility due to scattering with surface acoustic phonons,  $\mu_b$  is the carrier mobility in bulk silicon, and  $\mu_{sr}$  is the carrier mobility limited by surface roughness scattering.

The Lombardi model is a more physics-based surface mobility model. It is a semi-empirical model for carrier mobility, and the expressions for the individual scattering mechanisms were extracted from experimental data taken in appropriate experimental conditions.

The expressions used in this model are given below:

$$\mu_{ac,n} = \frac{bn}{E_{\perp}} + \frac{cnN^{exn4}}{T(E_{\perp})^{1/3}} \tag{2.23}$$

is the expression for electron mobility for acoustic phonon scattering,

$$\mu_{ac,p} = \frac{bp}{E_{\perp}} + \frac{cpN^{exp4}}{T(E_{\perp})^{1/3}} \quad (2.24)$$

is the expression for hole mobility for acoustic phonon scattering,

$$\mu_{b,n} = \mu_{n0} + \frac{\mu_{max,n} - \mu_{n0}}{1 + (N/crn)^{exn1}} - \frac{\mu_{n1}}{1 + (csn/N)^{exn2}} \quad (2.25)$$

is the expression for bulk mobility for electrons, where

$$\mu_{max,n} = \mu_{n2} \left( \frac{T}{T_{ref}} \right)^{-exn3} \quad (2.26)$$

and

$$\mu_{b,p} = \mu_{p0} \exp(-pc/N) + \frac{\mu_{max,p}}{1 + (N/crp)^{exp1}} - \frac{\mu_{p1}}{1 + (csp/N)^{exp2}} \quad (2.27)$$

is the expression for bulk mobility for holes, where

$$\mu_{max,p} = \mu_{p2} \left( \frac{T}{T_{ref}} \right)^{-exp3} \quad (2.28)$$

The expression for electrons for surface roughness scattering is

$$\mu_{sr,n} = \left( \frac{dn}{E_{\perp}^{exp8}} \right) \quad (2.29)$$

and the expression for holes for surface roughness scattering is

$$\mu_{sr,p} = \left( \frac{dp}{E_{\perp}^{exp8}} \right) \quad (2.30)$$

The parameters for the lombardi surface mobility model are given in Table 6.

Parameter	Silicon	GaAs
$\mu_{n0}$	52.2	0.0
$\mu_{n1}$	43.4	0.0
$\mu_{n2}$	1417.0	1e6
crn	9.68e16	9.68e16
csn	3.43e20	0.0
bn	4.75e7	1e10
cn	1.74e5	0.0
dn	5.82e14	1e6
exn1	0.680	0.0
exn2	2.0	0.0
exn3	2.5	0.0
exn4	0.125	0.0
exn8	2.0	0.0
$\mu_{p0}$	44.9	0.0
$\mu_{p1}$	29.0	0.0
$\mu_{p2}$	470.5	1.0
crp	2.23e17	2.23e17
csp	6.1e20	0.0
bp	9.93e6	1e10
cp	8.84e5	0.0
dp	2.05e14	1e6
exp1	0.719	0.0
exp2	2.0	0.0
exp3	2.2	0.0
exp4	0.0317	0.0
exp8	2.0	0.0
pc	9.23e16	0.0

Table 2.54: Lombardi Surface Mobility Parameters

## Edge Mobilities

Mobility values are calculated along the edge connecting two nodes. In the case of the analytic, arora, and surface mobility models, the edge mobilities are calculated by taking the average of the mobilities at the two nodes. Then, the mobility along the edge connecting nodes 1 and 2 is:

$$\mu_{edge} = (\mu[1] + \mu[2])/2.0 \quad (2.31)$$

In the case of the carrier-carrier scattering mobility, the edge mobilities were calculated differently. The electron and hole concentrations were first calculated at the midpoint of the edge using a "product" average and then these values of "n" and "p" were used in the function to calculate the mobility at the midpoint of the edge. For example, if n[1] and n[2] are the electron concentrations at nodes 1 and 2, the electron concentration along the edge is given by:

$$n_{edge} = \sqrt{n[1] * n[2]} \quad (2.32)$$

Subsequently, the mobility at the midpoint of an edge is found by using the values of electron and hole concentration at the midpoint of the edge when calling the function which returns the mobility, calcMob().

$$\mu_{n,edge}^{carrier} = f(n_{edge}) \quad (2.33)$$

This method makes more sense, especially when the electron and hole concentrations vary by several orders of magnitude. Then it approximates taking the average of the logarithms.

## Boundary Conditions for Electrode Contacts

This section describes various boundary conditions that need to be applied to the semiconductor boundary. **Xyce** is predominantly an analog circuit simulator, and the TCAD (PDE-based) device modeling that has been implemented in **Xyce** takes external circuit information as input. This input consists of voltages and currents which are applied as boundary conditions to the semiconductor domain.

The physical connection from the circuit to the device generally includes a variety of materials, including metals and oxides. Electrical differences between the semiconductor and

the contact material can result in a potential barrier that must be included in the imposed voltage boundary condition.

There are three general types of contacts between the circuit and the TCAD device which are currently handled by **Xyce**. The first is the "neutral" contact, in which it is simply assumed that the electrode material does not impose any additional potential barrier to that of the Fermi level differences in the semiconductor. The second is the Schottky contact, in which the electrode is a specified metal, and a potential barrier is imposed to account for the workfunction difference between the metal and the semiconductor. The last type of contact is the metal-oxide-semiconductor contact, in which the workfunction difference, and the voltage drop across the oxide must be accounted for.

### Neutral Contacts

A neutral contact refers to the case in which the contact is made to the semiconductor itself, and barrier heights due to material differences are not considered. This is the simplest type of contact in **Xyce**, and problems which use this type of contact are generally easier to solve, compared with other types of contacts. In this case, the boundary is given by

$$V_{bc} = V_{ckt} + V_{bi} \quad (2.34)$$

where  $V_{ckt}$  is the potential applied by the circuit and  $V_{bi}$  is the "built-in" potential of the semiconductor. For a p-type substrate, the built-in potential is given by

$$V_{bi} = -\frac{kT}{q} \ln\left(\frac{N_A}{n_i}\right) \quad (2.35)$$

and for an n-type substrate, the built-in potential is given by

$$V_{bi} = \frac{kT}{q} \ln\left(\frac{N_D}{n_i}\right) \quad (2.36)$$

$V_{bi}$  represents the extent of the energy band bending due to the doping of a device. While most of the dramatic changes will happen away from the contact, near junctions, it is still incorporated into the voltage boundary condition to maintain a flat potential near the contacts. Figure 2.2 shows the energy band variation across a PN junction, and the corresponding electrostatic potential. This variation is due to the internal physics of the device,

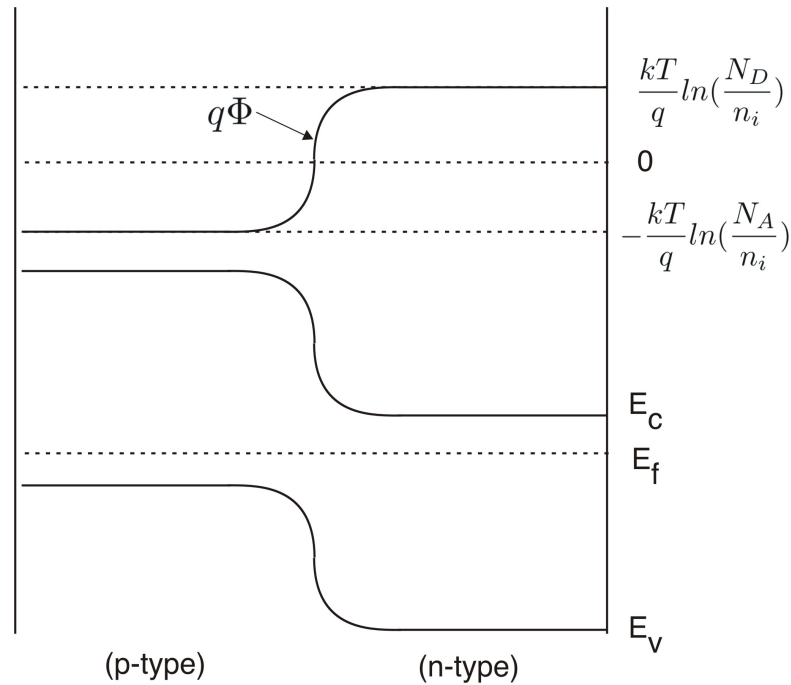

**Figure 2.2.** Neutral Contacts.

and needs to be there even in the event of zero applied voltage. This is partially enforced by the solution to Poisson's equation, and also by the application of equation 2.34.

### Schottky Contacts

In the case of a metal-semiconductor contact, it is necessary to add the workfunction difference,  $\Phi_{ms}$ , to the potential in the semiconductor [31].  $\Phi_m$  is a constant for a given metal, and  $\Phi_s$  is a function of the doping in the semiconductor. The workfunction potential,  $\Phi$ , when multiplied by  $q$ , is the difference between the Fermi level and vacuum in the material. In essence, the workfunction difference represents the distance between the Fermi level in the metal and the Fermi level in the semiconductor when considering the individual band structures.

In the case of an n-type semiconductor, the semiconductor workfunction can be represented as

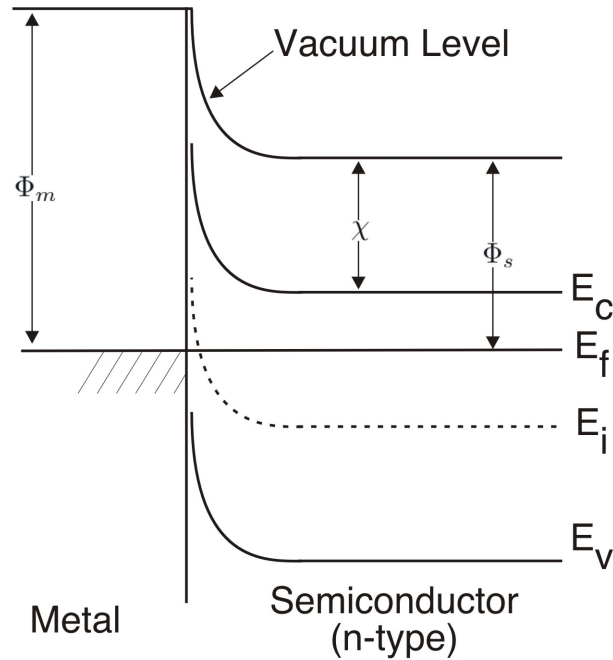

**Figure 2.3.** Schottky Contact, N-type.

$$\Phi_s = \chi + (E_C - E_{FS})/q \tag{2.37}$$

where  $\chi$  is the electron affinity in the semiconductor and  $q\chi$  is the distance between the conduction band and vacuum in the semiconductor.  $E_C$  is the conduction band energy and  $E_{FS}$  is the Fermi level of the semiconductor. Rewriting this expression in terms of the doping concentration, it becomes

$$\Phi_s = \chi + E_g/2 - V_t \ln\left(\frac{N_d}{n_i}\right) \tag{2.38}$$

In the case of a p-type semiconductor, the semiconductor workfunction can be represented as

$$\Phi_s = \chi + E_g/2 + (E_i - E_{FS})/q \tag{2.39}$$

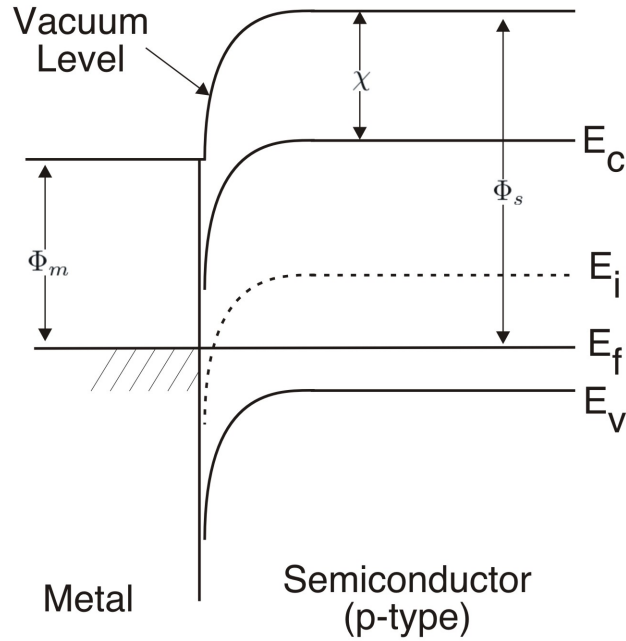

**Figure 2.4.** Schottky Contact, P-type.

where  $E_i$  is the intrinsic value of the Fermi level, and can be approximated as the halfway point between the conduction band ( $E_C$ ) and the valance band ( $E_V$ ). Rewriting this expression in terms of the doping concentration

$$\Phi_s = \chi + E_g/2 + V_t \ln\left(\frac{N_a}{n_i}\right) \quad (2.40)$$

For the TCAD devices in **Xyce**, for a node at a metal-semiconductor contact, the quantity  $\Phi_m - \Phi_s$  is added to the potential at the node to account for the metal-semiconductor barrier. The current values of metal workfunctions used in **Xyce** are given in Table 2.55. The values for electron affinity are given in Table 2.56. The boundary condition for a metal electrode in **Xyce** is given by

$$V_{bc} = V_{ckt} + V_{bi} + \Phi_{ms} \quad (2.41)$$

where  $V_{ckt}$  is the potential applied by the circuit to the electrode and  $V_{bi}$  is the "built-in"

potential of the semiconductor, a function of the semiconductor doping.

<b>Metal</b>	<b>Symbol</b>	<b>Workfunction, <math>\Phi_m</math> (Volts)</b>
aluminum	al	4.10
p+-polysilicon	ppoly	5.25
n+-polysilicon	npoly	4.17
molybdenum	mo	4.53
tungsten	w	4.63
molybdenum disilicide	modi	4.80
tungsten disilicide	wdi	4.80
copper	cu	4.25
platinum	pt	5.30
gold	au	4.80

Table 2.55: Material workfunction values

<b>Semiconductor</b>	<b>Symbol</b>	<b>Electron Affinity, <math>\chi</math> (Volts)</b>
Silicon	si	4.17
Germanium	ge	4.00
Galium Arsenide	gaas	4.07
Silicon Dioxide	sio2	0.97
Nitride	nitride	0.97
Sapphire	sapphire	0.97

Table 2.56: Electron affinities

## Metal-Oxide-Semiconductor Contacts

To date in **Xyce**, only semiconductor material is included in the PDE solution domain. Metals and oxide materials are currently only included through boundary conditions. This is an adequate approach for a lot of problems. For some problems (such as modeling of low-dose radiation effects) modeling the oxide in more detail, as a PDE, will become necessary. However, since oxides are usually very thin, compared with the semiconductor domain, meshing both materials as part of the same simulation is difficult. Therefore, incorporating the effects of a gate oxide as part of the gate boundary condition is a reasonable approach.

In the case of a contact to a metal-oxide-semiconductor structure, the separation of the Fermi energies in the metal and the semiconductor at equilibrium is due to two effects: the workfunction difference between the metal and the semiconductor, and the effective interface charge. These two effects cause the bands to bend at the surface in equilibrium. The flatband voltage is the sum of these two terms [31]:

$$V_{FB} = \Phi_{ms} - \frac{Q_i}{C_i} \quad (2.42)$$

where  $\Phi_{ms}$  is the metal-semiconductor workfunction difference,  $Q_i$  is the value of interface charge (in  $C/cm^2$ ), and  $C_i$  is the oxide capacitance per unit area, which is given by

$$C_i = \frac{\epsilon_{ox}\epsilon_0}{x_o} \quad (2.43)$$

The voltage  $V_{FB}$  is the amount of bias which, when applied to the gate, causes the electron energy bands to be flat. This is the potential that is added to a boundary node in **Xyce** to account for a metal-oxide-semiconductor barrier. The overall boundary condition for a contact to a metal-oxide-semiconductor structure is given by

$$V_{bc} = V_{ckt} + V_{bi} + \Phi_{ms} - Q_i/C_i \quad (2.44)$$

where  $V_{ckt}$  is the potential applied by the circuit and  $V_{bi}$  is the "built-in" potential of the semiconductor.

## NMOS Device

The default NMOS device currently used in **Xyce** has a substrate doping concentration of  $1.0 \times 10^{16}/cm^3$  and an oxide thickness of  $1.0 \times 10^{-6}cm$ . Since the ideal threshold voltage  $V_T$  is given by

$$V_T = 2\phi_F + \frac{\epsilon_s}{\epsilon_{ox}} x_o \sqrt{\frac{2qN_A\phi_F}{\epsilon_s\epsilon_0}} \quad (2.45)$$

$V_T$  is equal to 0.892 V. for this device. Note that

$$\phi_F = \frac{1}{q}[E_i(bulk) - E_F] = \frac{kT}{q} \ln\left(\frac{N_A}{n_i}\right) \quad (2.46)$$

for a p-type semiconductor substrate and

$$\phi_F = -\frac{kT}{q} \ln\left(\frac{N_D}{n_i}\right) \quad (2.47)$$

for an n-type substrate.



# 3. Command Line Arguments

---

**Xyce** supports a handful of command line arguments which must be given *before* the netlist filename. While most of these are intended for general use, others simply give access to new features that, while supported, are not enabled by default. These options are designated as *trial* options. The general usage is as follows:

```
runxyce [arguments] <netlist filename>
```

Table 3.1 gives a complete lists of command line options.

Argument	Description	Usage	Default
-h	Help option. Prints usage and exits.	-h	-
-v	Prints the version banner and exits.	-v	-
-delim	Set the output file field delimiter.	-delim <TAB COMMA string>	-
-o	Place the results into specified file.	-o <file>	-
-l	Place the log output into specified file.	-l <file>	-
-r	Output a binary rawfile.	-r <file>	-
-a	Use with -r to output a readable (ascii) rawfile.	-r <file> -a	-
-nox	Use the NOX nonlinear solver.	-nox <ON OFF>	on
-info	Output information on parameters.	-info [device prefix] [level] [ON OFF]	-
-linsolv	Set the linear solver.	-linsolv <KLU  SUPERLU AZTECOO>	klu(serial) and aztecoo(parallel)

Argument	Description	Usage	Default
-param	Print a terse summary of model and/or device parameters.	-param [<device prefix> [<level> [<INST MOD>] ] ]	-
-syntax	Check netlist syntax and exit.	-syntax	-
-norun	Netlist syntax and topology and exit.	-norun	-
-maxord	Maximum time integration order.	-maxord <1..5>	-
-gui	GUI file output.	-gui	-
-jacobian_test	Jacobian matrix diagnostic.	-jacobian_test	-

Table 3.1: List of **Xyce** command line arguments.

# 4. Runtime Environment

---

## Running **Xyce** in Serial

Use the `runxyce` script to run serial versions of **Xyce**. This script sets the environment variables, `LD_LIBRARY_PATH` or `DYLD_LIBRARY_PATH`, and starts Xyce. No additional runtime configuration is necessary.

## Running **Xyce** in Parallel

Open MPI must be installed on the host machine. It may be download from

<http://www.open-mpi.org/>. Consult the documentation for help with installation.

Use the `xmpirun` to run parallel versions of **Xyce**. This script sets the environment variables, `LD_LIBRARY_PATH` or `DYLD_LIBRARY_PATH`, and starts Xyce using the `mpiexec` wrappers.

## Running **Xyce** on Sandia HPC Platforms

In addition to the steps above for running **Xyce**, there is a **xyce** module available that sets the runtime environment (Open MPI, Intel MKL, Intel Compilers, etc.). To load the module, use the command:

```
module load xyce
```

Consult the system documentation for help with submitting jobs on these platforms.

<https://computing.sandia.gov/>



# 5. Setting Convergence Parameters for **Xyce**

---

Because the solution algorithms and methods within **Xyce** are different than those used by other circuit simulation tools (e.g., ChileSPICE), the overall convergence behavior is sometimes different as are the parameters which control this behavior.

With **Xyce** Release 4.0 several of the default transient parameters have been changed to improve overall performance and help make **Xyce** more competitive with other codes. While these defaults have been extensively tested to ensure acceptable accuracy, it is possible that some accuracy has been lost in order to provide improved performance. While this is likely negligible, accuracy can be improved by tightening the error tolerances and/or changing the time-integration order from their default values. As this is typically an issue for transient simulations, the following discussion applies to that context only. For a complete list of available solution control options, go to 2.1 in chapter 2.

## Adjusting Transient Analysis Error Tolerances

As of Release 4.0, the default for **Xyce** is to use a variable order Backward Differentiation Formula (BDF 1-5) time integration method (also known as a 1-5 step Gear method) for performing transient analysis [32]. This method starts out with Backward Euler on the first few steps and then ramps up to as high an order as will maintain stability and which takes the largest time steps. The maximum order it can attain is five and this can be reduced with the `MAXORD` option. It is also possible to set a minimum order which the integrator should maintain with the option `MINORD`. When `MINORD` is set, the integrator will move upward in order from Backward Euler as quickly as possible to achieve `MINORD` and then it will adjust the order between `MINORD` and `MAXORD` to maintain stability and take large steps. See table 2.2 for details.

**Xyce** also supports variable order trapezoid integration through the `TIMEINT` option `METHOD=7`. Trapezoid time-stepping is second order accurate and does not have any numerical dissipation in its local truncation error. Variable order trapezoid integration dynamically uses

Backward euler (BE) and trapezoid rule. When `ERROPTION=1` is set with `METHOD=7`, trapezoidal rule is used almost exclusively (BE only used at breakpoints). See table 2.2 for details.

## Setting RELTOL and ABSTOL

In **Xyce**, there is currently `RELTOL` and `ABSTOL` settings for both the time integration package and the nonlinear solver package. Some general guidelines for settings parameters are [32]:

- Use the *same* `RELTOL` and `ABSTOL` values for both the `TIMEINT` and the `NONLIN-TRAN .OPTIONS` statements.
- For a conservative approach (i.e., safe), set `RELTOL=1.0E-(m+1)` where `m` is the desired number of significant digits of accuracy.
- Set `ABSTOL` to the smallest value at which the solution components (either voltage or current) are essentially insignificant.
- *Note* that the above suggests that `ABSTOL < RELTOL`.

The current defaults for these parameters are `ABSTOL=1.0E-6` and `RELTOL = 1.0E-2`. For a complete list of the time integration parameters, see chapter 2.1.

## Adjusting Nonlinear Solver Parameters (in transient mode)

In **Xyce**, the nonlinear solver options for transient analysis are set using the `.OPTIONS NONLIN-TRAN` line in a netlist. This subsection gives some guidelines for setting this parameters.

- For guidelines on setting `RELTOL` and `ABSTOL`, see above.
- `RHSTOL` – This is the maximum residual error for each nonlinear solution. **Xyce** uses this as a “safety” check on nonlinear convergence. Typically, `1.0E-2` (the default) works well.
- `DELTA XTOL` – This is the weighted update norm tolerance and is the primary check for nonlinear convergence. Since it is weighted (i.e., normalized using `RELTOL` and `ABSTOL`), a value of `1.0` would give it the same accuracy as the time integrator. For robustness, the default is `0.33` but sometimes a value of `0.1` may help prevent “time-step too small” errors. A value of `0.01` is considered quite small.

- **MAXSTEP** – This is the maximum number of Newton (nonlinear) steps for each nonlinear solve. In transient analysis, the default is 20 but can be increased to help prevent “time-step too small” errors. This is roughly equivalent to ITL4 in ChileSPICE.



# 6. Quick Reference for Orcad PSpice Users

---

This chapter describes many of the differences between **Xyce** and Orcad PSpice with an eye towards providing the ability for those familiar with using PSpice to begin using **Xyce** quickly. **Xyce** is still under development, so this section will change as new capabilities are added to **Xyce**. Also, note that there is also a quick reference chapter for ChileSPICE users 7, and many of the issues covered in that chapter are also applicable to PSpice.

## GUI Support

There is currently no Graphical User Interface (GUI) support for Xyce.

## Command Line Options

Command line arguments are supported in **Xyce** but they are different than those of PSPICE. For a complete reference, see chapter 3.

## Device Support

Most, but not all, devices commonly found in circuit simulation tools are supported. **Xyce** also contains enhanced versions of many semiconductor devices that simulate various environmental effects. For the complete list, please see the Analog Device Summary in Table 2.9.

## Netlist Support

To the extent that specific devices or models are supported in **Xyce**, it supports most of the standard netlist inputs as may be found in standard SPICE. However, the `.OPTIONS` command has several additional features used to expose capabilities specific to **Xyce**. In

particular, **Xyce** does not currently support the standard PSpice format `.OPTIONS` line in netlists. Instead, package specific `.OPTIONS` lines are supported according to the following format: `.OPTIONS {PKG} <<TAG=>VALUE> ...`. The **Xyce** packages which currently support `.OPTIONS` are:

Package	PKG keyword
Global:	GLOBAL
Device Model:	DEVICE
Time Integration:	TIMEINT
Nonlinear Solver:	NONLIN
Transient Nonlinear Solver:	NONLIN-TRAN
Continuation/Bifurcation Tracking:	LOCA
Linear Solver:	LINSOL
Output:	OUTPUT
Restart:	RESTART
MPDE:	MPDEINT
Harmonic Balance:	HBINT

For a complete description of the supported options, see section 2.1.

**Xyce** does not support the `.PROBE` statement. Output of Probe format files is done using the `.PRINT` netlist statement. See chapter 2 for syntax.

**Xyce** does not support PSPICE style abbreviations in the `.PRINT` statement. For example, to print out the value of the voltage at node A in a transient simulation you must request `.PRINT TRAN V(A)`, not `.PRINT TRAN A`.

## Converting PSpice ABM Models for Use in Xyce

As of the **Xyce** Version 3.0 release, **Xyce** is almost fully compatible with PSpice with respect to analog behavioral models. This includes the E, F, G, and H device types. A notable exception to this compatibility is in the use of lead and device currents in expressions. These are limited to expressions in the `.PRINT` statement.

## Usage of .STEP Analysis

The implementation of .STEP in **Xyce** is not yet fully compatible with that of PSpice. This will be corrected in subsequent releases of **Xyce**.

### Sweep Type

PSpice supports four different sweep types: linear, octave, decade, and list. All of these are supported in Xyce.

### Global .PARAM Sweeps

PSpice also supports sweeps over variables specified in .PARAM lines. This is not supported in **Xyce**. This block of text will not work in **Xyce**:

```
VAB 2 0 5
VAC 1 0 variable
.param variable=0
.step param variable 0 5 1
.dc VAB 4 5 1
```

.PARAM with a .global\_param, and removal of the param keyword from the .STEP line:

```
.global_param variable=0
VAB 2 0 5
VAC 1 0 variable
.step variable 0 5 1
.dc VAB 4 5 1
```

### Model Parameter Sweeps

PSpice requires extra keywords to apply a .STEP statement to a model parameter. **Xyce** handles model parameters differently, and is actually somewhat more flexible. Unfortunately, this means that the two specifications are not compatible.

A model parameter in PSpice would be handled like this:

```
R1 1 2 RMOD 1
.model RMOD RES(R=30)
.step RES RMOD(R) 30 50 5
```

The equivalent way to specify this in **Xyce** would be:

```
R1 1 2 RMOD 1
.model RMOD RES(R=30)
.step RMOD:R 30 50 5
```

Note that **Xyce** does not require the RES keyword on the .STEP line. In PSpice, this keyword is needed to specify what type of model is being used. **Xyce** actually has more flexibility than PSpice in this regard - any model or instance variable can be set, on the .STEP line, using the same syntax.

**Example:**            .step D101:IS 1.0e-3 5.0e-3 1.0e-3

In this example, D101 is the name of a model, or instance, and IS is the name of the parameter within that model or instance.

## Other differences

Some other differences between **Xyce** and PSpice are described in table 6.1.

Issue	Comment
.VECTOR, .WATCH, and .PLOT output control analysis are not supported.	<b>Xyce</b> currently does not support these commands. If enough users request them, they may be supported in the future.
.AC, .FOUR, .NOISE, .SENS and .TF analysis types are not supported.	<b>Xyce</b> fully supports .DC and .TRAN analysis. .OP is partially supported. .AC and .SENS are planned features. Other analyses, such as .NOISE may be supported in the future, if enough users request them.
.MC and .WCASE statistical analyses are not supported.	<b>Xyce</b> currently does not support these commands. If enough users request them, they may be supported in the future.

Issue	Comment
.DISTRIBUTION, which defines a user distribution for tolerances, is not supported.	<b>Xyce</b> does not support this command. This command goes along with .MC and .WCASE statistical analyses, which are also not supported.
.LOADBIAS, .SAVEBIAS, and .NODESET initial condition commands are not supported.	<b>Xyce</b> does not support these commands.
.ALIASES, .ENDALIASES, are not supported.	<b>Xyce</b> does not support these commands.
.STIMULUS is not supported.	<b>Xyce</b> does not support this command.
.TEXT is not supported.	<b>Xyce</b> does not support this command.
.SAVE does not work	<b>Xyce</b> does not support this. Use .PRINT instead.
.PROBE does not work	<b>Xyce</b> does not support this. Use the FORMAT=PROBE option of .PRINT instead. See section 2 for syntax.
.OP is incomplete	An .OP netlist will run in <b>Xyce</b> , but will not produce the extra output normally associated with the .OP statement.
.SENS is only supported in the development builds of <b>Xyce</b>	This is currently a research issue in <b>Xyce</b> , and will be available in later release versions of <b>Xyce</b> .
Pulsed source rise time of zero	A requested pulsed source rise/fall time of zero really is zero in <b>Xyce</b> . In other simulators, requesting a zero rise/fall time causes them to use the printing interval found on the tran line.
Mutual Inductor Model	Not the same as PSpice. This is a Sandia developed model.
.PRINT line shorthand	Output variables have to be specified as a V(node) or I(source). Listing the node alone will not work.
BSIM3 level	In <b>Xyce</b> the BSIM3 level=9. In PSpice the BSIM3 is level=8.
Node names vs. device names	Currently, circuit nodes and devices <i>MUST</i> have different names in <b>Xyce</b> . Some simulators can handle a device and a node with the same name, but <b>Xyce</b> cannot.
Interactive mode	<b>Xyce</b> does not have an interactive mode.

Issue	Comment
Time integrator default tolerances	<b>Xyce</b> has much tighter default solver tolerances than some other simulators (e.g., PSpice), and thus often takes smaller time steps. As a result, it will often take a greater number of total time steps for a given time interval. To have <b>Xyce</b> take time steps comparable to those of PSpice, set the RELTOL and ABSTOL time integrator options to larger values (e.g., RELTOL=1.0E-2, ABSTOL=1.0E-6).
.OPTIONS statements	<b>Xyce</b> does not support PSpice style .OPTION statements. In <b>Xyce</b> , the various packages all (potentially) have their own separate .OPTIONS line in the netlist. For a complete description, see section 2.1.
DTMAX	<b>Xyce</b> does support a maximum time step-size control on the .tran line, but we discourage its use. The time integration algorithms within <b>Xyce</b> use adaptive time-stepping methods that adjust the time-step size according to the activity in the analysis. If the simulator is not providing enough accuracy, the RELTOL and ABSTOL parameters should be decreased for both the time integration package (.OPTIONS TIMEINT) and the transient nonlinear solver package (.OPTIONS NONLIN-TRAN). We have found that in most cases specifying the same maximum timestep that PSpice requires for convergence actually slows Xyce down by preventing it from taking larger timesteps when the behavior warrants.
Nonlinear Dependent Source (B source) syntax	<b>Xyce</b> requires curly braces around all ABM expressions, where PSpice does not. See section 2.
.TRAN "UIC" keyword	PSpice requires the use of a keyword UIC on the .TRAN line in order to use initial conditions via IC keywords on instance lines. Doing so also tells PSpice not to perform an operating point calculation. In <b>Xyce</b> , UIC is ignored and produces a warning message. <b>Xyce</b> always uses initial conditions specified with IC keywords, and the case of inductors and capacitors automatically inserts a fictitious voltage source around the device that guarantees the correct potential drop across the device during the operating point. If the user desires that Xyce not perform an operating point calculation, but rather use an initial condition for a transient run of all zero voltages, then the user should specify NOOP instead.
Temperature specification	Device temperatures in <b>Xyce</b> are specified through the .OPTIONS DEVICE line. PSpice allows a .TEMP line that is not recognized (and is ignored) by <b>Xyce</b> .

Table 6.1: Incompatibilities with PSpice.

# 7. Quick Reference for ChileSPICE Users

---

A large number of potential **Xyce** users have experience using Sandia's ChileSPICE circuit simulator, which is a shared-memory parallel code based on Berkely's SPICE version 3f5. Table 7.1 lists some of the differences between ChileSPICE and **Xyce**. Many of these are the same as the differences between PSpice and **Xyce**, which were listed in table 6.1.

Issue	Comment
.SAVE does not work	<b>Xyce</b> does not support this. Use .PRINT instead.
.PROBE does not work	<b>Xyce</b> does not support this. Use the FORMAT=PROBE option of .PRINT instead. See section 2 for syntax.
.OP is incomplete	An .OP netlist will run in <b>Xyce</b> , but will not produce the extra output normally associated with the .OP statement.
Pulsed source rise time of zero	A requested pulsed source rise/fall time of zero really is zero in <b>Xyce</b> . In other simulators, requesting a zero rise/fall time causes them to use the printing interval found on the tran line.
Mutual Inductor Model	Not the same as PSPICE. This is a Sandia developed model.
.PRINT line shorthand	Output variables have to be specified as a V(node) or I(source). Listing the node alone will not work.
BSIM3 level	In <b>Xyce</b> the BSIM3 level=9. In ChileSPICE the BSIM3 is level=8.
Node names vs. device names	Currently, circuit nodes and devices <i>MUST</i> have different names in <b>Xyce</b> . Some simulators can handle a device and a node with the same name, but <b>Xyce</b> cannot.
Time integrator default tolerances	<b>Xyce</b> has much tighter default solver tolerances than some other simulators (e.g., ChileSPICE), and thus often takes smaller time steps. As a result, it will often take a greater number of total time steps for a given time interval. To have <b>Xyce</b> take time steps comparable to those of ChileSPICE, set the RELTOL and ABSTOL time integrator options to larger values (e.g., RELTOL=1.0E-2, ABSTOL=1.0E-6).

Issue	Comment
ChileSPICE-specific "operating point voltage sources"	These are not currently supported within <b>Xyce</b> . The capacitor, inductor, BSIM3, and B3SOI are the only devices that currently support the "IC=" parameter, both insert the equivalent of operating-point voltage sources automatically when an initial condition is given.
.OPTIONS statements	<b>Xyce</b> does not support ChileSPICE style .OPTION statements. In <b>Xyce</b> , the various packages all (potentially) have their own separate .OPTIONS line in the netlist. For a complete description, see section 2.1.
DTMAX	<b>Xyce</b> does support a maximum time step-size control on the .tran line, but we discourage its use. The time integration algorithms within <b>Xyce</b> use adaptive time-stepping methods that adjust the time-step size according to the activity in the analysis. If the simulator is not providing enough accuracy, the RELTOL and ABSTOL parameters should be decreased for both the time integration package (.OPTIONS TIMEINT) and the transient nonlinear solver package (.OPTIONS NONLIN-TRAN). We have found that in most cases specifying the same maximum timestep that ChileSPICE requires for convergence actually slows Xyce down by preventing it from taking larger timesteps when the behavior warrants.
Nonlinear Dependent Source (B source) syntax	<b>Xyce</b> requires curly braces around all ABM expressions, where ChileSPICE does not. See section 2.
.TRAN "UIC" keyword	SPICE 3F5 requires the use of a keyword UIC on the .TRAN line in order to use initial conditions via IC keywords on instance lines. Doing so also tells SPICE 3F5 not to perform an operating point calculation. In <b>Xyce</b> , UIC is ignored and produces a warning message. <b>Xyce</b> always uses initial conditions specified with IC keywords, and the case of inductors and capacitors automatically inserts a fictitious voltage source around the device that guarantees the correct potential drop across the device during the operating point. If the user desires that Xyce not perform an operating point calculation, but rather use an initial condition for a transient run of all zero voltages, then the user should specify NOOP instead.
Temperature specification	Device temperatures in <b>Xyce</b> are specified through the .OPTIONS DEVICE line. ChileSPICE allows a .TEMP line that is not recognized (and is ignored) by <b>Xyce</b> .

Issue	Comment
AREA parameter for radiation aware devices	The diode and BJT support a parameter on the instance line called AREA, and in both standard and radiation aware devices this is used to scale certain model parameters. In ChileSPICE this same parameter is used to scale the photocurrent. In <b>Xyce</b> it is used only to scale the model parameters, and a new model parameter DEVICEAREA is used to scale the photocurrent. This enables SPUDS data sets for real devices to be used unmodified except for the addition of the radiation-specific parameters. ChileSPICE requires that the scaled model parameters be adjusted to take into account the device area parameter.
.STEP syntax is not the same.	This issue is well covered in the PSpice quick reference. See section 6.

Table 7.1: Incompatibilities with ChileSPICE.



# 8. Quick Reference for Microsoft Windows Users

---

**Xyce** is supported on Microsoft Windows. However, the primary targets for **Xyce** are high-performance supercomputers and workstations, which are almost always running a variant of Unix. Also, 99% of **Xyce** development is done on Unix platforms. Bearing this in mind, there are occasionally issues with using a Unix application on a Windows platform. Some of these issues are described in the table below.

Issue	Comment
File names need to be case-sensitive	<b>Xyce</b> will expect library files, which are referenced in the netlist, to have exactly the same case as the actual filename. If not, <b>Xyce</b> will be unable to find the library file.
<b>Xyce</b> is unable to read proprietary file formats.	Programs such as Microsoft Word by default use file formats that <b>Xyce</b> cannot recognize. It is best not to use such programs to create netlists, unless netlists are saved as *.txt files. If you must use a Microsoft editor, it is better to use Microsoft Notepad. In general, the best solution is to use a Unix-style editor, such as Vi, Gvim, or Emacs.

Table 8.1: Issues for Microsoft Windows.



# 9. Rawfile Format

---

The rawfile format produced by **Xyce** closely follows Spice3 conventions. Differences are noted in section 9. Details on the both the ascii and binary formats are provided here for reference.

## Ascii Format

The ascii format consists of lines or sets of lines introduced by a keyword. The `Title` and `Date` lines should be the first in the file and should occur only once, followed by the `Plotname`, `Flags`, `No. Variables`, `No. Points`, `Variables`, and `Values` lines. Note that after the `Variables` keyword there must be *numvars* declarations of outputs, and after the `Values` keyword, there must be *numpoints* lines, each consisting of *numvars* values.

## Binary Format

The binary format is similar to the ascii format, except that strings are null terminated rather than newline terminated. Binary storage of real values as double precision floats is architecture specific.

## Special Notes

- Complex data points are not used.
- `Commands` and `Options` lines are not used.
- Limited to single dimension and single plot.
- Binary header is formatted ascii.

Line Name	Description
Title:	An arbitrary string describing the circuit
Date:	A free-format date string
Plotname:	A string describing the analysis type
Flags:	A string describing the analysis type. <i>real</i>
No. Variables:	The number of variables
Variables:	The number of points
Variables:	A newline followed by multiple lines, one for each variable, of the form [tab] <index> [tab] <name> [tab] <type> where type is either <i>current</i> or <i>voltage</i> .
Values:	A newline followed by multiple lines, for each point and variable, of the form [tab] <value> with an integer index preceding each set of points.

**Table 9.1.** Xyce ascii rawfile format.

Line Name	Description
Title:	An arbitrary string describing the circuit
Date:	A free-format date string
Plotname:	A string describing the analysis type
Flags:	A string describing the analysis type. <i>1</i>
No. Variables:	The number of variables
Variables:	The number of points
Variables:	A newline followed by multiple lines, one for each variable, of the form [tab] <index> [tab] <name> [tab] <type> where type is either <i>current</i> or <i>voltage</i> .
Binary:	Each real data point is stored contiguously in sizeof(double) byte blocks.

**Table 9.2.** Xyce binary rawfile format.

## Bibliography

- [1] Eric R. Keiter, Thomas V. Russo, Eric L. Rankin, Richard L. Schiek, Heidi K. Thornquist, Deborah A. Fixel, Todd S. Coffey, Roger P. Pawlowski, Keith R. Santarelli, and Christina E. Warrender. Xyce parallel electronic simulator: User's guide, version 5.2. Technical Report SAND2011-xxxx, Sandia National Laboratories, Albuquerque, NM, 2011.
- [2] Orcad PSpice User's Guide. Technical report, Orcad, Inc., 1998.
- [3] T. Banwell. Bipolar transistor circuit analysis using the lamber w-function. *IEEE Transactions on Circuits and Systems*, 47(11):1621–1633, November 2000.
- [4] R. S. Tuminaro, M. A. Heroux, S. A. Hutchinson, and J. N. Shadid. Official Aztec User's Guide: Version 2.1. Technical report, Sandia National Laboratories, Albuquerque, NM, December 1999.
- [5] Arthur P. Mattuck. *Introduction to Analysis*. Prentice Hall, Inc., 1999.
- [6] H. K. Gummel and H. C. Poon. An integral charge control model of bipolar transistors. *Bell Sys. Techn. J.*, May-June:827–852, 1970.
- [7] Colin McAndrew, Mark Dunn, Shahriar Moinian, and Michael Schröter. VBIC95, The Vertical Bipolar Inter-Company Model. *IEEE Journal of Solid-State Circuits*, 31(10):1476–1483, 1996.
- [8] A. S. Grove. *Physics and Technology of Semiconductor Devices*. John Wiley and Sons, Inc., 1967.
- [9] P. Antognetti and G. Massobrio. *Semiconductor Device Modeling with SPICE*. McGraw-Hill, 1988.
- [10] J.H. Huang, Z.H. Liu, M.C. Jeng, K. Hui, M. Chan, P.K. KO, and C. Hu. BSIM3 Manual. Technical report, Department of Electrical Engineering and Computer Science, University of California, Berkeley, CA 94720.

- [11] P. Su, H. Wan, S. Fung, M. Chan, A. Niknejad, and C. Hu. BSIM3SOI3.1 MOSFET MODEL Users' Manual. Technical report, Department of Electrical Engineering and Computer Science, University of California, Berkeley, CA 94720.
- [12] P. Su, H. Wan, S. Fung, M. Chan, A. Niknejad, and C. Hu. BSIM3SOI3.2 documentation. Technical report, Department of Electrical Engineering and Computer Science, University of California, Berkeley, CA 94720.
- [13] T. A. Fjeldly, T. Ytterdal, and M. Shur. *Introduction to Device Modeling and Circuit Simulation*. Wiley InterScience, 1998.
- [14] G. Gildenblat, X. Li, W.Wu, H. Wang, A. Jha, R. van Langevelde, G.D.J. Smit, A.J. Scholten, and D.B.M. Klaassen. Psp: An advanced surface-potential-based mosfet model for circuit simulation. *IEEE Transactions on Electron Devices*, 53(9):1979–1993, 2006.
- [15] M. Bucher, C. Lallement, C. Enz, F. Theodoloz, and F. Krummenacher. The EPFL/EKV MOSFET Model Equations for Simulation Technical Report: Model Version 2.6. Technical report, Electronics Laboratories, Swiss Federal Institute of Technology (EPFL), Lausanne, Switzerland, September 1997.
- [16] M. Bucher, A. Bazigos, E. Kitonaki, and F. Krummenacher. Recent advances in the ekv3 mos transistor model. In *NANOTECH 2006, Workshop on Compact Models*, May 2006.
- [17] M. Bucher, D. Diamantakos, A. Bazigos, and F. Krummenacher. Design-oriented characterization and parameter extraction methodologies for the ekv3 mosfet model. In *NANOTECH 2007 Workshop on Compact Modeling*, May 2007.
- [18] A. Vladimirescu and S. Lui. The Simulation of MOS Integrated Circuits using SPICE2. Technical Report Memorandum No. M80/7, February 1980.
- [19] H. Shichman and D. A. Hodges. Modeling and simulation of insulated-gate field-effect transistor switching circuits. *IEEE Journal of Solid-State Circuits*, SC-3:285, September 1968.
- [20] B. J. Sheu, D. L. Scharfetter, P.-K. Ko, and M.-C. Jeng. Bsim: Berkeley short-channel igfet model for mos transistors. *IEEE Journal of Solid-State Circuits*, SC-22:558–566, August 1987.
- [21] J. R. Pierret. A MOS Parameter Extraction Program for the BSIM Model. Technical Report Memorandum No. M84/99 and M84/100, November 1984.

- [22] Ping Yang, Berton Epler, and Pallab K. Chatterjee. An investigation of the charge conservation problem for mosfet circuit simulation. *IEEE Journal of Solid-State Circuits*, SC-18(1), February 1983.
- [23] BSIM3v3.1 Manual. Technical report, Department of Electrical Engineering and Computer Science, University of California, Berkeley, CA 94720.
- [24] J. C. Bowers and H. A. Neinhuis. SPICE2 Computer Models for HEXFETs. Technical Report Application Note 954A, International Rectifier Corporation, Berkeley, CA 94720.
- [25] K. M. Kramer and W. N. G. Hitchon. *Semiconductor Devices: A Simulation Approach*. Prentice-Hall, 1997.
- [26] C. D. Thurmond. The standard thermodynamic function of the formation of electrons and holes in ge, si, gaas, and gap. *J. Electrochem. Soc.*, 122:1133, 1975.
- [27] D.M. Caughey and R.E. Thomas. Carrier mobilities in silicon empirically related to doping and field. *Proc. IEEE*, 55:2192–2193, 1967.
- [28] N.D. Arora, J.R. Hauser, and D.J. Roulston. Electron and hole mobilities in silicon as a function of concentration and temperature. *IEEE Transactions on Electron Devices*, ED-29:292–295, 1982.
- [29] J.M. Dorkel and Ph. Leturq. Carrier mobilities in silicon semi-empirically related to temperature, doping, and injection level. *Solid-State Electronics*, 24(9):821–825, 1981.
- [30] C. Lombardi, S. Manzini, A. Saporito, and M. Vanzi. A physically based mobility model for numerical simulation of nonplanar devices. *IEEE Transactions on Computer-Aided Design*, 7(11):1164–1170, November 1988.
- [31] Ben G. Streetman and Sanjay Banerjee. *Solid State Electronic Devices*. Prentice-Hall, Upper Saddle River, New Jersey, 2000.
- [32] K.E. Brenan, S.L. Campbell, and L.R. Petzold. *Numerical Solution of Initial-Value Problems in Differential-Algebraic Equations*. Society for Industrial and Applied Mathematics, Philadelphia, 1996.



## Index

- .PREPROCESS, 69
  - ADDRESSISTORS, 70
  - REMOVEUNUSED, 70
  - REPLACEGROUND, 69
- Xyce**
  - ABSTOL, 296
  - RELTOL, 296
  - convergence, 295
- .FUNC, 43
- .GLOBAL\_PARAM, 45
- .INC, 44
- .MEASURE, 36
- .OPTIONS, 46, 300, 304, 306
- .PARAM, 44
- .PRINT
  - Expressions, 42
- .PRINT, 29, 30, 38
- .SUBCKT, 32
- ABSTOL, 49, 59
- BPENABLE, 54
- EXITSTEP, 55
- EXITTIME, 55
- MAXSTEP, 59
- NLNEARCONV, 50
- NLSMALLUPDATE, 50
- RELTOL, 49, 59
- RESTARTSTEPSCALE, 50
- .DC, 20
- .HB, 30
- .MPDE, 31
- .STEP, 23
- .TRAN, 27, 66
- RESTART, 67
- accelerated mass device, 263
- adms vbic
  - device model parameters, 112
- algorithm
  - time integration, 304, 306
- analysis
  - control parameters, 46
  - DC, 20, 57
    - Decade sweeps, 21
    - Linear sweeps, 20
    - List Sweeps, 22
    - Octave sweeps, 21
  - HB, 30
  - MPDE, 31
  - options, 46
  - STEP
    - Decade sweeps, 24
    - Linear sweeps, 23
    - List sweeps, 25
    - Octave sweeps, 25
  - step, 23
  - transient, 27, 29, 57
- Aztec, 64
- behavioral digital
  - instance parameters, 261
  - model parameters, 262
- bias point, 29

- BJT, 105
  - model parameters, 109
  - operating temperature, 107
- bsim3
  - device model parameters, 154
- bsim3 soi
  - device model parameters, 178
- bsim4
  - device instance parameters, 180
  - device model parameters, 208
- bsource, 104
- capacitor, 76
  - instance parameters, 77
  - model parameters, 78
- checkpoint, 67
  - format, 67
- ChileSPICE, 305, 307
- command line, 292
  - arguments, 291
- controlled switch, 254
  - model parameters, 256
- convergence, 295
- current controlled current source, 101
- current controlled voltage source, 102
- current source
  - current controlled, 101
  - independent, 95
  - nonlinear dependent, 104
  - voltage controlled, 103
- DC analysis, 20, 57
  - Decade sweeps, 21
  - Linear sweeps, 20
  - List sweeps, 22
  - Octave sweeps, 21
- device
  - ABM device
    - PSpice equivalent, 300
  - analog, 72
  - analog device summary, 74
  - B source, 72
  - bipolar junction transistor (BJT, 73
  - BJT, 105
  - bsource, 104
  - capacitor, 72, 76
  - controlled switch, 254
  - current controlled current source, 73, 101
  - current controlled switch, 73
  - current controlled voltage source, 73, 102
  - digital, 259
  - Digital Devices, 74
  - diode, 72, 89
  - equations, 72
  - generic switch, 257
  - independent current source, 73
  - independent voltage source, 73, 95, 99
  - inductor, 73, 79
  - JFET, 73, 116
  - lossless transmission line, 258
  - MESFET, 74, 119
  - MOSFET, 73, 122
  - mutual inductor, 73
  - mutualinductor, 81
  - nodes, 75
  - nonlinear dependent source, 72
  - package options, 47
  - PDE Devices, 74, 265
  - resistor, 73, 85
  - ROM Devices, 74
  - subcircuit, 73
  - transmission line, 73
  - voltage controlled current source, 73, 103
  - voltage controlled switch, 73
  - voltage controlled voltage source, 73, 100
- Digital Devices, 74
- digital devices, 259
- diode, 89
  - instance parameters, 90
  - model parameters, 91
  - operating temperature, 89

- ekv3 mosfet
  - device instance parameters, 239
  - device model parameters, 247
- generic switch, 257
- GUI, 299
- harmonic balance analysis, 30
- independent voltage source, 95, 99
- inductor, 79
  - model parameters, 80
- JFET, 116
- jfet
  - instance parameters, 117
  - model parameters, 118
- Lambert-W Function, 48
- lossless transmission line, 258
  - model parameters, 258
- MESFET, 119
- mesfet
  - instance parameters, 120
  - model parameters, 121
- mesh, 267, 268
- Microsoft Windows, 309
- model, 72
  - definition, 32
- MOSFET, 122
- mosfet level 1
  - device model parameters, 133
- mosfet level 2
  - device model parameters, 135
- mosfet level 3
  - device model parameters, 137
- mosfet level 6
  - device model parameters, 139
- mpde, 55, 57
- multi-time partial differential equation analysis, 31
- mutualinductor, 81
- netlist
  - commands, 20
  - comment, 45
  - in-line comment, 45
  - line continuation, 46
  - nodes, 75
  - reference, 19
- nonlinear mutual inductor
  - device model parameters, 83
- Operating Point, 20
- output
  - control, 36
- parallel
  - computing, 13
- parameters
  - convergence, 295
- PDE Devices, 74, 265
  - doping parameters, 269
  - electrode parameters, 270
  - instance parameters, 268
  - model parameters, 268
  - Physical Models, 271
  - time integration parameters, 53
- power mosfet
  - instance parameters, 208
  - model parameters, 211
- psp103va mosfet
  - device instance parameters, 212
  - device model parameters, 238
- PSpice, 299, 304
  - E device, 300
  - F device, 300
  - G device, 300
  - H device, 300
  - Probe, 40
- rawfile, 311

- ascii, 311
- binary, 311
- resistor, 85
  - device instance parameters, 87
  - device model parameters, 88
  - instance parameters, 86
  - model parameters, 86
- restart, 67
  - file, 68
  - format, 68
  - two-level, 68
- results
  - measure, 36
  - output control, 36
  - output options, 66
  - print, 29, 30, 38
- ROM Devices, 74
- Sandia National Laboratories, 13
- solvers
  - continuation
    - options, 62, 63
  - control parameters, 46
  - hb
    - options, 57
  - homotopy
    - options, 62
  - linear
    - Aztec, 64
    - iterative (preconditioned Krylov methods), 64
    - options, 64, 66
    - sparse-direct, 64
    - Trilinos, 64
  - nonlinear
    - options, 57, 62, 296
  - nonlinear-transient
    - options, 62
  - time integration
    - options, 295
    - time integration, 29, 304, 306
      - options, 49, 55
- STEP analysis
  - Decade sweeps, 24
  - Linear sweeps, 23
  - List sweeps, 25
  - Octave sweeps, 25
- step parametric analysis, 23
- subcircuit, 32, 72, 264
  - designation, 34
  - name, 33
  - nesting, 34
  - node zero, 34
  - scoping, 34
- TCAD Devices, 265
  - model parameters, 268
  - Physical Models, 271
- texttt.MEASURE, 36
- time step
  - size, 29, 304, 306
- transient analysis, 27, 57
  - error tolerances, 295
- Trilinos, 64
- Unix, 14
- Users of ChileSPICE, 305
- Users of PSpice, 299
- Users of Xyce on Microsoft Windows, 309
- voltage controlled current source, 103
- voltage controlled voltage source, 100
- Voltage Nodes, 75
- voltage source
  - current controlled, 102
  - independent, 99
  - nonlinear dependent, 104
  - voltage controlled, 100

## DISTRIBUTION:

1 Wendland Beezhold  
Idaho Accelerator Center  
1500 Alvin Ricken Drive  
Pocatello, Idaho 83201

Unless otherwise noted, all of the following copies were distributed electronically

1 MS 0316  
Keith Santarelli, 1412

1 MS 0316  
Joseph P. Castro, 1437

1 MS 0316  
Deborah Fixel, 1437

1 MS 0316  
Gary Hennigan, 1437

1 MS 0316  
Robert J. Hoekstra, 1437

1 MS 0316  
Eric R. Keiter, 1437

1 MS 0316  
Paul Lin, 1437

1 MS 0316  
Biliana Paskaleva, 1437

1 MS 0316  
Eric L. Rankin, 1437

1 MS 0316  
Thomas V. Russo, 1437

1 MS 0316  
Richard Schiek, 1437

1 MS 0316  
John N. Shadid, 1437

1 MS 0316  
Heidi K. Thornquist, 1437

1 MS 0321  
Jamesw Peery, 1400

1 MS 0321  
John Mitchiner, 1430

1 MS 0340  
Mark J. De Spain, 2123

1 MS 0344  
Joshua Michael Schare, 2626

1 MS 0348  
Markus Johannes Hoffmann,  
5351

1 MS 0348  
Garth M. Kraus, 5353

1 MS 0348  
George Laguna, 5351

1 MS 0348  
John Dye, 5351

1 MS 0351  
Charles Barbour, 1010

1 MS 0351  
H. Morgan, 1030

1 MS 0352  
Charles Hembree, 1344

1 MS 0352  
Steven D. Wix, 1734

1 MS 0352  
Teresa Gutierrez, 17311

- |  |  |
|--|--|
| 1 MS 0372<br>Stephen T. Montgomery, 1524 | 1 MS 0525<br>Regina Schells, 1734              |
| 1 MS 0382<br>Kenneth Noel Belcourt, 1543 | 1 MS 0529<br>Christopher L. Gibson, 5355       |
| 1 MS 0405<br>Ben Long, 0425              | 1 MS 0529<br>Steven Dunlap, 5356               |
| 1 MS 0405<br>C. W. Bogdan, 0425          | 1 MS 0635<br>Daniel R. Cantu, 2957             |
| 1 MS 0405<br>Glenn L. Rice, 0425         | 1 MS 0672<br>Zachary Benz, 5635                |
| 1 MS 0405<br>John L. Tenney, 0425        | 1 MS 0807<br>Philip M. Campbell, 9326          |
| 1 MS 0406<br>Jason Dimkoff, 5712         | 1 MS 0807<br>David N. Shirley, 9326            |
| 1 MS 0429<br>Ronald Hartwig, 2100        | 1 MS 0808<br>Shekita Lavette Robinson,<br>2132 |
| 1 MS 0447<br>Douglas R. Weiss, 2127      | 1 MS 0824<br>Joel Lash, 1510                   |
| 1 MS 0457<br>Robert Paulsen, 2011        | 1 MS 0828<br>Anthony A. Giunta, 1544           |
| 1 MS 0479<br>Scott Klenke, 2138          | 1 MS 0828<br>Vicente Romero, 1544              |
| 1 MS 0481<br>Christopher R. Landry, 2132 | 1 MS 0829<br>Brian Rutherford, 0415            |
| 1 MS 0503<br>Arthur J. Gariety, 5339     | 1 MS 0889<br>Neil R. Sorensen, 1825            |
| 1 MS 0525<br>Adam H. Lester, 1732        | 1 MS 0899<br>Technical Library, 9536           |
| 1 MS 0525<br>Albert V. Nunez, 1734       | 1 MS 0956<br>Steven C. Anderson, 2434          |
|  | 1 MS 1056<br>Edward Bielejec, 1111             |

- |   |  |
|---|--|
| 1 MS 1056<br>Gyorgy Vizkelethy, 1111          | 1 MS 1146<br>Patrick Grifn, 1384                 |
| 1 MS 1056<br>William Wampler, 1111            | 1 MS 1152<br>Michael F. Pasik, 1654              |
| 1 MS 1069<br>Glenn Omdahl, 1711               | 1 MS 1153<br>Larry D. Bacon, 5443                |
| 1 MS 1071<br>Dahlon Chu, 1730                 | 1 MS 1153<br>Robert A. Salazar, 5443             |
| 1 MS 1072<br>Nathan Nowlin, 1731              | 1 MS 1159<br>James Bryson, 1344                  |
| 1 MS 1072<br>Richard Flores, 1731             | 1 MS 1159<br>Kyle McDonald, 1344                 |
| 1 MS 1073<br>G. Ronald Anderson, 1717         | 1 MS 1159<br>Victor Harper-Slaboszewicz,<br>1344 |
| 1 MS 1076<br>Alan F. Lundin, 1737             | 1 MS 1165<br>Paul N. Demmie, 5435                |
| 1 MS 1083<br>Kenneth E. Kambour, 17311        | 1 MS 1167<br>St. Dominic Bonaparte, 1343         |
| 1 MS 1083<br>Paul Dodd, 17311                 | 1 MS 1179<br>Harry Hjalmarson, 1341              |
| 1 MS 1084<br>Timothy L. Meisenheimer,<br>1748 | 1 MS 1179<br>Leonard Lorence, 1341               |
| 1 MS 1085<br>Albert Baca, 1742                | 1 MS 1179<br>Mark Hedemann, 1340                 |
| 1 MS 1137<br>Greg D. Valdez, 6323             | 1 MS 1182<br>Derek C. Lamppa, 5445               |
| 1 MS 1138<br>Harvey C. Ogden, 6325            | 1 MS 1188<br>Christina E. Warrender, 6343        |
| 1 MS 1146<br>Donald King, 1384                | 1 MS 1219<br>Charles L. Kandra,, 5924            |
|   | 1 MS 1316<br>Elebeoba E. May, 1412               |

- 
- |   |   |
|---|---|
| 1 MS 1316<br>Mark D. Rintoul, 1412              | 1 MS 1322<br>John Aidun, 1435           |
| 1 MS 1318<br>Brian M. Adams, 1411               | 1 MS 1322<br>Sudip Dosanjh, 1420        |
| 1 MS 1318<br>Karen Devine, 1416                 | 1 MS 1385<br>Ken Mulder, 1143           |
| 1 MS 1318<br>Mike Eldred, 1411                  | 1 MS 1411<br>Allen Roach, 1814          |
| 1 MS 1318<br>Bruce Hendrickson, 1410            | 1 MS 1411<br>Edmund B. Webb III, 1814   |
| 1 MS 1318<br>Roger Pawlowski, 1414              | 1 MS 1415<br>David Sandison, 1110       |
| 1 MS 1318<br>Andrew Salinger, 1414              | 1 MS 1415<br>Robert Fleming, 1123       |
| 1 MS 1318<br>Laura Swiler, 1411                 | 1 MS 1415<br>Samuel Myers, 1110         |
| 1 MS 1318<br>Bart van Bloemen Waanders,<br>1414 | 1 MS 9003<br>Donna J. O'Connell, 8112   |
| 1 MS 1319<br>Arun F. Rodrigues, 1422            | 1 MS 9003<br>Karen L. Jefferson, 8112   |
| 1 MS 1319<br>William C. McLendon III, 1423      | 1 MS 9004<br>Gary K. Lum, 8100          |
| 1 MS 1320<br>Todd Coffey, 1414                  | 1 MS 9004<br>William Ballard, 8100      |
| 1 MS 1320<br>David Day, 1414                    | 1 MS 9007<br>Brian Owens, 8205          |
| 1 MS 1320<br>Mike Heroux, 1416                  | 1 MS 9007<br>Dean F. Clark, 8205        |
| 1 MS 1320<br>James Willenbring, 1416            | 1 MS 9007<br>Elizabeth C. Wichman, 8205 |
|   | 1 MS 9013<br>Derek I. Koida, 8231       |

- |                                   |   |
|-----------------------------------|---|
| 1 MS 9013<br>Lee D. Druxman, 8231 | 1 MS 9106<br>Daniel Dominguez Jr., 8226 |
| 1 MS 9102<br>David Council, 8229  | 1 MS 9106<br>Steven Paradise, 8226      |
| 1 MS 9102<br>Jim He, 8135         | 1 MS 9158<br>Ting Mei, 1437             |
| 1 MS 9102<br>Kevin Lam, 8135      | 1 MS 9159<br>Genetha Gray, 8964         |
| 1 MS 9102<br>Rex I. Eastin, 8135  |   |
| 1 MS 9103<br>Cheryl Lam, 8942     | 1 MS 0899<br>Technical Library, 9536    |